

0364 0363 0365 0366

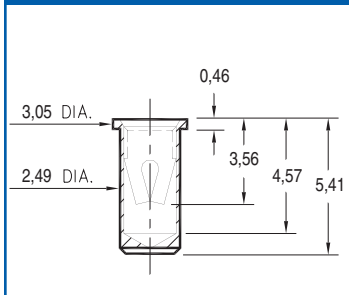

0364-0-15-XX-13-XX-10-0
Solder mount in 2,54 min. mounting hole
Also available on 16mm wide carrier tape: 1,300 parts per 330mm reel.
Order as: 0364-0-57-XX-13-XX-10-0

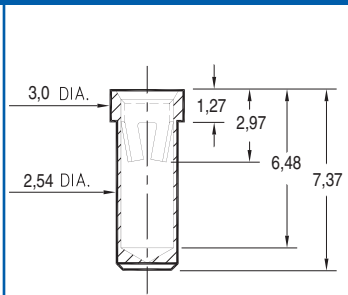

0363-0-15-XX-23-XX-10-0
Solder mount in 2,59 min. mounting hole

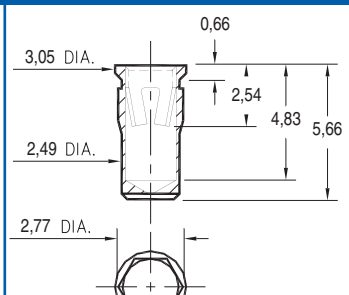

0365-0-15-XX-23-XX-10-0
Hex press-fit in 2,67 plated thru hole

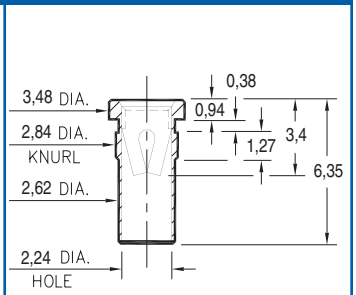

0366-0-15-XX-13-XX-10-0
Press-fit in 2,77 mounting hole

0372 0362 0367 9324

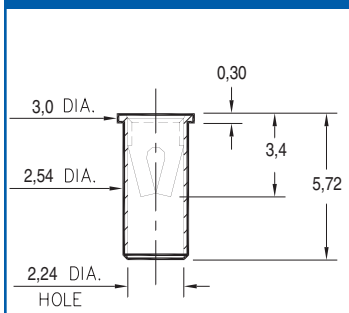

0372-0-15-XX-13-XX-10-0
Solder mount in 2,59 min. mounting hole

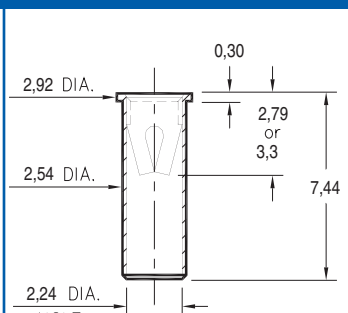

0362-0-15-XX-X3-XX-10-0
Solder mount in 2,59 min. mounting hole

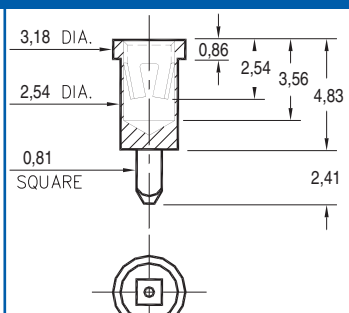

0367-0-15-XX-23-XX-10-0
Square press-fit in 1,02 plated thru hole

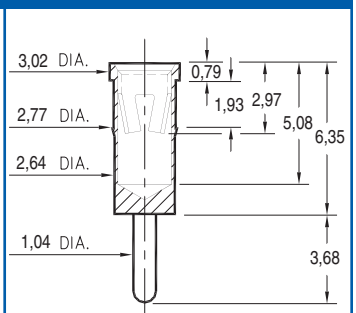

9324-0-15-XX-23-XX-04-0
Press-fit in 2,69 mounting hole

0492 0381 4034 3044

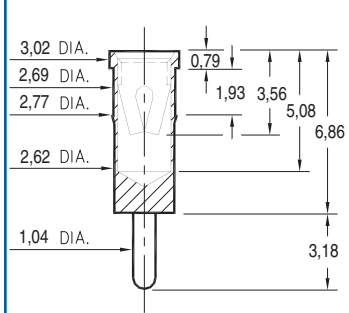

0492-0-15-XX-13-XX-04-0
Press-fit in 2,69 mounting hole

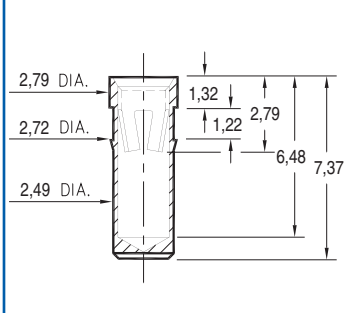

0381-0-15-XX-23-XX-10-0
Press-fit in 2,64 mounting hole

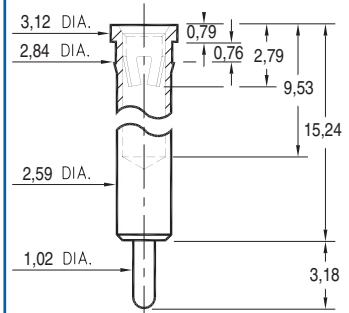

4034-0-15-XX-23-XX-04-0
Press-fit in 2,77 mounting hole

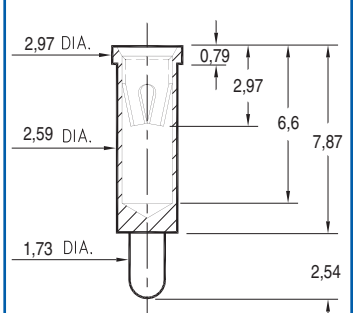

3044-0-15-XX-23-XX-04-0
Solder mount in 2,64 min. mounting hole

<p>SPECIFICATIONS</p> <p>SHELL MATERIAL: Brass Alloy 360, 1/2 Hard</p> <p>CONTACT MATERIAL: Beryllium Copper Alloy 172, HT</p> <p>PART MANUFACTURED IN INCHES, METRIC FOR REF ONLY</p> <p>TOLERANCES ON: LENGTHS: ± 0,13 DIAMETERS: ± 0,05 ANGLES: ± 2°</p>	<p>ORDER CODE: XXXX - X - 15 - XX - X3 - XX - XX - 0</p> <p>BASIC PART # →</p> <p>SPECIFY SHELL FINISH: →</p> <p>01 5,08µm TIN/LEAD OVER NICKEL 80 5,08µm TIN OVER NICKEL ◊ 15 0,25µm GOLD OVER NICKEL ◊</p> <p>SPECIFY CONTACT FINISH: →</p> <p>01 5,08µm TIN/LEAD OVER NICKEL 80 5,08µm TIN OVER NICKEL ◊ 27 0,76µm GOLD OVER NICKEL ◊</p> <p align="center">SELECT CONTACT #13 or #23 CONTACT (DATA ON PAGE 214)</p>
--	--



Downloaded from Elcodis.com electronic components distributor