

Tous droits strictement réservés. Reproduction ou communication e des tiers interdite sous quelque forme que ce soit sans autorisation écrite du propriétaire. Property of FCI. Droits de reproduction FCI.

All rights strictly reserved. Reproduction or issue to third parties in any form whatsoever is not permitted without written authority from the proprietor. Property of FCI. Copyright FCI.

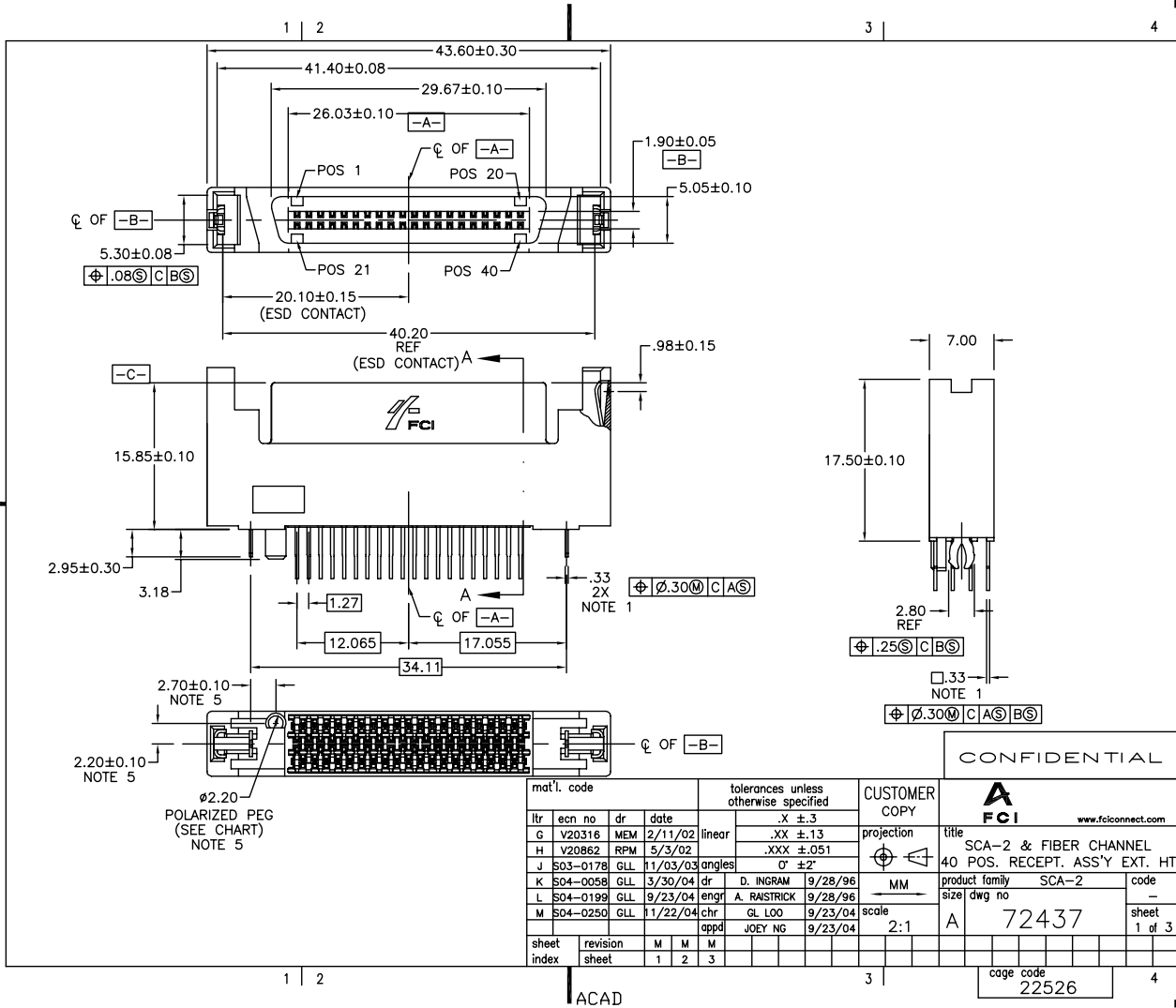

mat'l code		tolerances unless otherwise specified		CUSTOMER COPY		CONFIDENTIAL	
ltr	ecn no	dr	date	linear	projection	title	
G	V20316	MEM	2/11/02	.X ±.3	MM	SCA-2 & FIBER CHANNEL	
H	V20862	RPM	5/3/02	.XX ±.13	MM	40 POS. RECEPT. ASS'Y EXT. HT.	
J	S03-0178	GLL	11/03/03	.XXX ±.051	MM	product family	code
K	S04-0058	GLL	3/30/04	0 ±.2	MM	SCA-2	-
L	S04-0199	GLL	9/23/04	engr	D. INGRAM	9/28/96	size
M	S04-0250	GLL	11/22/04	chr	A. RAWSTRICK	9/28/96	dwg no
				appd	GL LOO	9/23/04	72437
				appd	JOEY NG	9/23/04	scale
				sheet	2:1	A	
sheet index	revision sheet	M	M	M			
		1	2	3			

Tous droits strictement réservés. Reproduction ou communication e des tiers interdite sous quelque forme que ce soit sans autorisation écrite du propriétaire. Property of FCI. Droits de reproduction FCI.

All rights strictly reserved. Reproduction or issue to third parties in any form whatever is not permitted without written authority from the proprietor. Property of FCI. Copyright FCI.

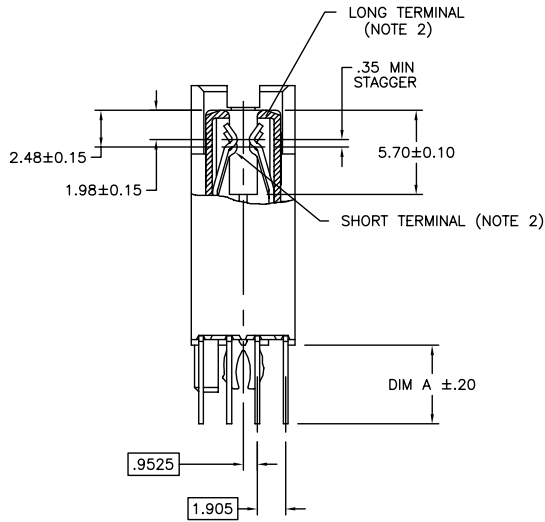

SECTION A-A

CONFIDENTIAL

mat'l. code		tolerances unless otherwise specified		CUSTOMER COPY		www.fciconnect.com	
ltr	ecn no	dr	date	linear	projection	title	
M				.X ±.3		SCA-2 & FIBER CHANNEL	
				.XX ±.13		40 POS. RECEPT. ASS'Y EXT. HT.	
				.XXX ±.051		product family SCA-2 code -	
				angles	MM	size	dwg no
				dr	scale	A	72437
				engr	3:1		sheet
				chr			2 of 3
				appd			
sheet index	revision sheet						

cage code 22526

ACAD

PDM: Rev:M

STATUS: Released

Printed: May 26, 2010

Tous droits strictement réservés. Reproduction ou communication e des tiers interdite sous quelque forme que ce soit sans autorisation écrite du propriétaire. Property of FCI. Droits de reproduction FCI.

All rights strictly reserved. Reproduction or issue to third parties in any form whatever is not permitted without written authority from the proprietor. Property of FCI. Copyright FCI.

PRODUCT NO.	DIM A	POLARIZATION PEG	PLATING	RECOMMENDED P.C. BOARD THICKNESS	PRODUCT NO.	PLATING	PRODUCT NO.	PLATING	PRODUCT NO.	PLATING
72437-001	2.79	YES	NOTE 4	1.57mm (0.062")	72437-101	NOTE 6	72437-001LF	NOTE 9	72437-201LF	NOTE 8
-001S					-101S				-002LF	
-002	2.79	NO		-102			-003LF		-203LF	
-002S				-102S			-004LF		-204LF	
-003	3.18	YES		-103			72437-005LF		72437-205LF	
-003S				-103S			-006LF		-206LF	
-004	3.18	NO		-104			-007LF		-207LF	
-004S			-104S							
-005	4.06	YES	3.18mm (0.125")	-105						
-005S				-105S						
-006	4.06	NO		-106						
-006S				-106S						
-007	4.60	YES		-107						
-007S				-107S						

NOTES :

- TRUE POSITION NOTES APPLY AT TERMINAL TIP.
- CONTACTS IN POSITIONS 1 THRU 20,24,25,27,28, 30, 31, 33, AND 34 ARE SHORT TERMINALS. CONTACTS IN POSITIONS 21, 22, 23, 26, 29, 32, AND 35 THRU 40 ARE LONG TERMINALS.
- RAW MATERIALS:
HOUSING: HTN, UL94V-0, COLOR: BLACK
CONTACTS: PHOSPHOR-BRONZE
- CONTACT PLATING: 30u" (0.76um) MIN. GXT PLATING OVER 50u" (1.27um) NICKLE MIN. UNDERPLATE IN CONTACT AREA. 100u" (2.54um) MIN TIN-LEAD PLATING OVER 50u" (1.27um) MIN NICKEL UNDERPLATE IN P.C. BOARD LEG AREA. 50u" (1.27um) MIN. NICKEL UNDERPLATE OVER REMAINING AREA.
- DIMENSIONS DO NOT APPLY TO CONNECTOR STYLES WITHOUT POLARIZATION PEG. (SEE CHART)
- CONTACT PLATING: 30u" (0.76um). MIN. GOLD PLATING OVER 50u" (1.27um) NICKLE MIN. UNDERPLATE IN CONTACT AREA. 100u" (2.54um) MIN TIN-LEAD PLATING OVER 50u" (1.27um) MIN NICKEL UNDERPLATE IN P.C. BOARD LEG AREA. 50u" (1.27um) MIN. NICKEL UNDERPLATE OVER REMAINING AREA.
- PART NUMBERS WITH AN "S" SUFFIX ARE MANUFACTURED WITH A BRIGHT TIN-LEAD FINISH ON THE TERMINAL TAIL SECTION. PART NUMBERS WITHOUT AN END SUFFIX ARE MANUFACTURED WITH MATTE TIN-LEAD FINISH OR MATTE TIN FINISH.
- CONTACT PLATING: 30u" (0.76um) GOLD PLATING OVER 50u" (1.27um) NICKEL UNDERPLATE IN CONTACT AREA. 100u" (2.54um) - 100u" (5.08um) TIN PLATING OVER P.C. BOARD LEG AREA. 50u" (1.27um) NICKEL UNDERPLATE OVER REMAINING AREA.
- CONTACT PLATING: 30u" (0.76um) GXT PLATING OVER 50u" (1.27um) NICKEL UNDERPLATE IN CONTACT AREA. 100u" (2.54um) - 200u" (5.08um) TIN PLATING OVER 50u" (1.27um) - 100u" (2.54um) NICKEL UNDERPLATE IN P.C. BOARD LEG AREA. 50u" (1.27um) NICKEL UNDERPLATE OVER REMAINING AREA.

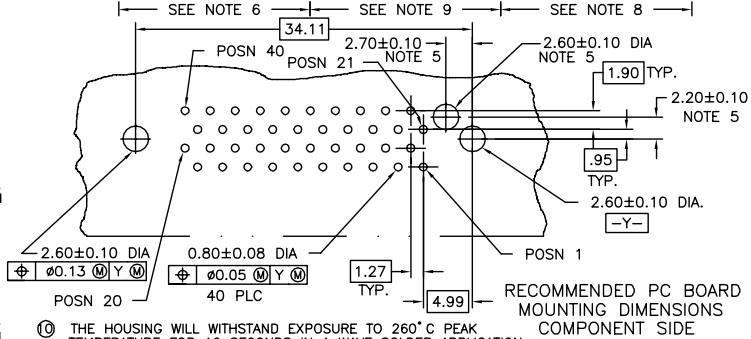

- THE HOUSING WILL WITHSTAND EXPOSURE TO 260°C PEAK TEMPERATURE FOR 10 SECONDS IN A WAVE SOLDER APPLICATION WITH A 1.57MM MINIMUM THICK CIRCUIT BOARD.
- THIS PRODUCT MEETS EUROPEAN UNION DIRECTIVES AND OTHER COUNTRY REGULATIONS AS DESCRIBED IN GS-22-008.
- PART NUMBERS ENDING IN "LF" MEANS FOR NOTE 11 LEAD FREE IDENTIFICATION. P/N XXXXX-2XXLF IS EQUIVALENT TO PREVIOUS P/N XXXXX-2XX

CONFIDENTIAL

mat'l. code		tolerances unless otherwise specified		CUSTOMER COPY		www.fciconnect.com	
lfr	ecr no	dr	date	linear	.X ±.3	projection	title
M					.XX ±.13		SCA-2 & FIBER CHANNEL
				angles	.XXX ±.051		40 POS. RECEPT. ASS'Y EXT. HT.
				dr	0 ±.2	MM	product family
				enrg	D. INGRAM 9/28/96	2:1	SCA-2
				chr	A. RAWSTRICK 9/28/96		code
				appd	GL LOO 9/23/04		72437
					JOEY NG 9/23/04		size
sheet	revision						dwg no
index	sheet						3 of 3

cage code 22526

ACAD