

FCI CONFIDENTIAL  
 This document is the property of and embodies CONFIDENTIAL and PROPRIETARY information of FCI. No part of the information shown here may be reproduced, stored in a retrieval system, or disclosed to others without the written consent of FCI.  
 Copyright FCI  
 FCIconnect.com

PRODUCT NO  
 SEE TABLE

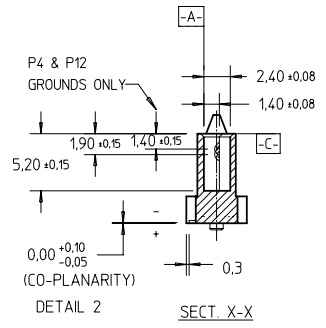
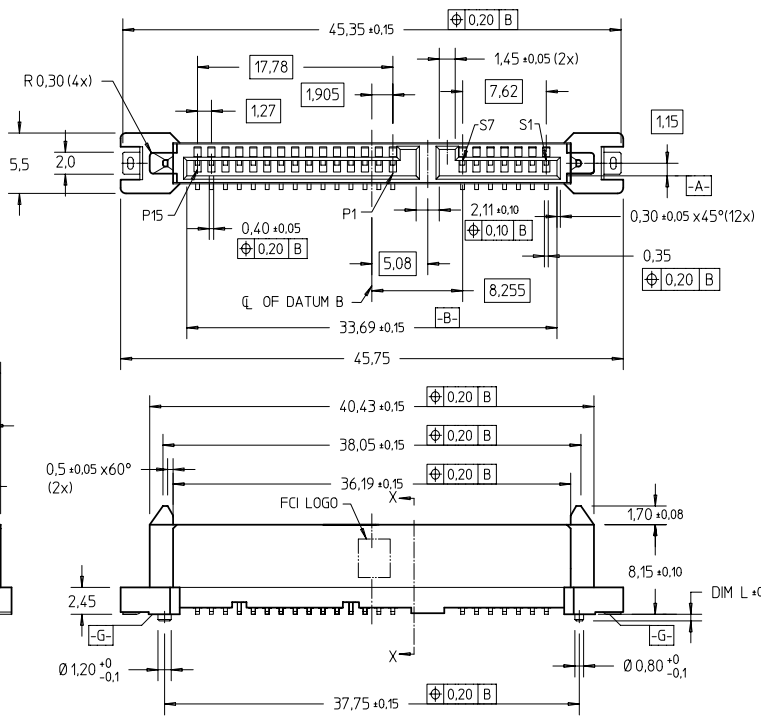

mat'l. code		surface	tolerance	projection	product family
		ISO 1302	ISO 406 ISO 1101		S-ATA
itr	ecn no	dr	date	title	
A	S06-0231	GLL	2006-07-06	S-ATA COMB RECP.	
B	S07-0079	GLL	2007-03-15	VERTICAL SMT TYPE ASSY	
C	S07-0268	GLL	2007-07-31	scale 2:1	
D	S09-0283	GLL	2009-09-09	dwg no 10042140	
sheet index		revision sheet	D 0 1 2	sheet 1 of 2 size A4	
		appd	JOEY NG	type CUSTOMER Drawing	

PDM: Rev:D STATUS Released 10042140C Rev D Printed: Apr 08, 2010

FCI CONFIDENTIAL



This document is the property of and embodies CONFIDENTIAL and PROPRIETARY information of FCI. No part of the information shown here may be reproduced, stored in a retrieval system, or transmitted in any form or by any means, electronic, mechanical, photocopying, recording, or otherwise, without the written consent of FCI. Copyright FCI.

PRODUCT NO	DIM L	PICK-UP CAP	PACKAGING
10042140-001LF	0.60	NO	STD TRAY
10042140-001CLF		YES	STD TRAY
10042140-001C-TRLF		YES	TAPE & REEL
10042140-003LF	1.45	NO	STD TRAY
10042140-003CLF		YES	STD TRAY
10042140-003C-TRLF		YES	TAPE & REEL

PRODUCT NO	DIM L	PICK-UP CAP	PACKAGING
10042140-002LF	0.60	NO	CUSTOM-MADE
10042140-002CLF		YES	TRAY

**NOTES:**

- 1 THE UNMATING FORCE SHALL NOT BE LESS THAN 5N.
- 2 MATERIAL:
  - 1) HOUSING : HIGH TEMP TERMOPLASTIC, UL 94V-0  
COLOR : BLACK
  - 2) TERMINAL : COPPER ALLOY
  - 3) HOLD DOWN : COPPER ALLOY
- 3 FINISH :
  - 1) TERMINAL : 30u" Au PLATING (CONTACT POINT) OVER 50u" NICKEL
  - 2) SOLDER TAIL : 50u" min Sn OVER 50u" NICKEL
  - 3) HOLD DOWN : 50u" min Sn OVER 50u" NICKEL
- 4 PART WITH PICK-UP CAP, P/N XXXXXXXX-XXXX LF
- 5 THE STD PACKAGING IS IN TRAY.
- 6 FOR TAPE & REEL PACKAGING, SUFFIX '-TR' ADDED  
P/N XXXXXXXX-XXXX-TR LF
- 7 THE HOUSING WILL WITHSTAND EXPOSURE TO 260°C PEAK TEMPERATURE FOR 10 SECONDS IN A CONVECTION, INFRA-RED OR VAPOR PHASE REFLOW OVEN.
- 8 THIS PRODUCT MEETS EUROPEAN UNION DIRECTIVES AND OTHER COUNTRY REGULATIONS AS DESCRIBED IN GS-22-008.
- 9 PART NUMBERS ENDING IN 'LF' MEANS FOR NOTE 8 LEAD FREE IDENTIFICATION.
- 10 A  $\Delta$  SYMBOL WILL BE NEXT TO ANY DIMENSION, VIEW, OR NOTE WHICH HAS BEEN MODIFIED WITH THE CURRENT DRAWING REVISION.

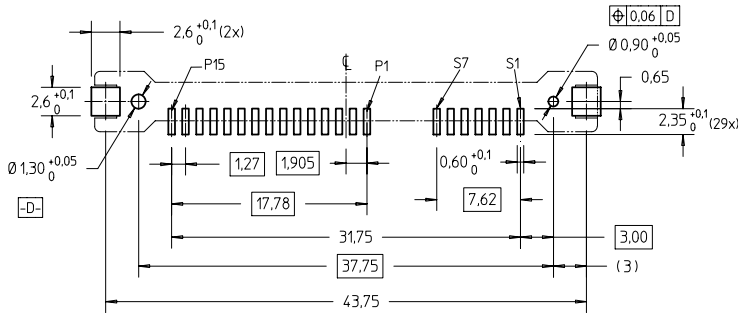

RECOMMENDED PCB LAYOUT

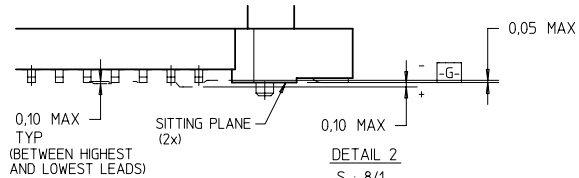

DETAIL 2  
S : 8/1

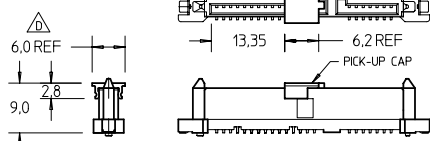

PART WITH PICK-UP CAP, SEE NOTE 4

mat'l. code		surface	tolerance	projection	product family
ISO 1302		ISO 406 ISO 1101	ISO 406 ISO 1101	$\phi$	S-ATA
tr	ecn no	dr	date	tolerances unless otherwise specified	title
D				angles	S-ATA COMB RECP.
				linear	VERTICAL SMT TYPE ASSY
				$\pm 2^\circ$	mm
					scale 2 : 1
		dr	QL L00	2005-12-20	dwg no
		enrg	QL L00	2005-12-20	10042140
		chr	QL L00	2009-09-09	sheet 2 of 2
		appd	JOEY NG	2009-09-09	A4
sheet	revision				type
index	sheet	1			CUSTOMER Drawing

PDM: Rev:D

STATUS Released

Printed: Apr 08, 2010