

PRODUCT NO.

JSC 96359

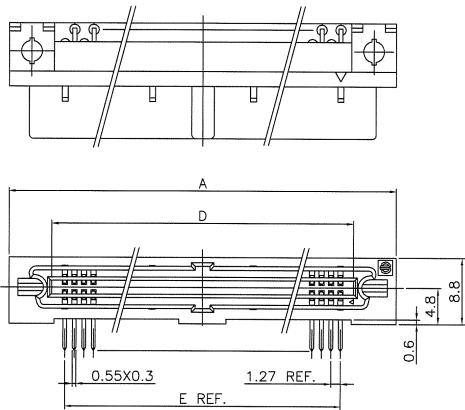

NO. OF CONTACTS:40,60,68,80,100,120

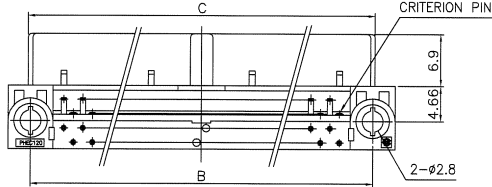

NOTES

1. BODY, LOCATOR MATERIAL : PBT CLASS FILLED (UL94V-0), COLOR BLACK
2. TERMINAL MATERIAL : PHOSPHOR BRONZE
3. MOUNTING LATCH MATERIAL : PHOSPHOR BRONZE
4. SCREW NUT : STEEL
5. TERMINAL FINISH  
 CONTACT AREA : GOLD FLASH 0.1μm min. OVER NICKEL UNDERLAYER  
 SOLDER TAILS : PURE Sn 2μm min. OVER NICKEL UNDERLAYER
6. MOUNTING LATCH FINISH : PURE Sn 2μm min. OVER NICKEL UNDERLAYER
7. SCREW NUT FINISH : NICKEL
8. THIS PRODUCT MEETS EUROPEAN UNION DIRECTIVES AND OTHER COUNTRY REGULATIONS AS DESCRIBED IN GS-22-008
9. THE HOUSING WILL WITHSTAND EXPOSURE TO 260 DEGREE PEAK TEMPERATURE FOR 10 SECONDS IN A WAVE SOLDER APPLICATION WITH A 1.6mm MINIMUM THICK CIRCUIT BOARD.

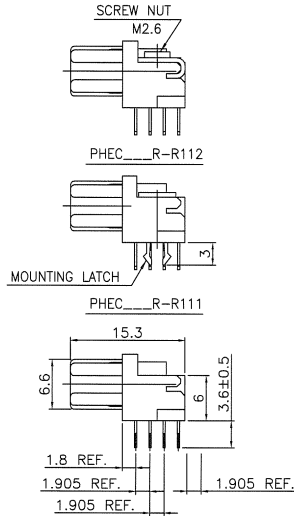

PHEC\_\_\_R-R110

NO. OF CONTACTS:30,34,50

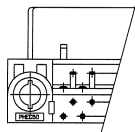

RECOMMENDED PC BOARD  
 THICKNESS:1.6±0.2  
 HOLE PATTERN (COMPONENT SIDE)

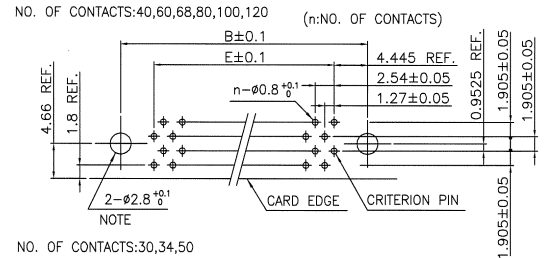

NO. OF CONTACTS:30,34,50

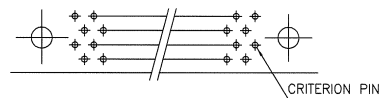

NOTE : THROUGH-HOLES FOR MOUNTING LATCHES ALSO SHOULD BE PLATED.

CAT. NO.	NO. OF CONTACTS (MATING SIDE)	DIMENSIONS				
		A	B	C	D	E
PHEC30R-R11_LF	15/ROW X 2 ROWS	32.67	26.67	27.26	21.26	17.78
PHEC34R-R11_LF	17/ROW X 2 ROWS	35.21	29.21	29.80	23.80	20.32
PHEC40R-R11_LF	20/ROW X 2 ROWS	39.02	33.02	33.61	27.61	24.13
PHEC50R-R11_LF	25/ROW X 2 ROWS	45.37	39.37	39.96	33.96	30.48
PHEC60R-R11_LF	30/ROW X 2 ROWS	51.72	45.72	46.31	40.31	36.83
PHEC68R-R11_LF	34/ROW X 2 ROWS	56.80	50.80	51.39	45.39	41.91
PHEC80R-R11_LF	40/ROW X 2 ROWS	64.42	58.42	59.01	53.01	49.53
PHEC100R-R11_LF	50/ROW X 2 ROWS	77.12	71.12	71.71	65.71	62.23
PHEC120R-R11_LF	60/ROW X 2 ROWS	89.82	83.82	84.41	78.41	74.93

mat'l. code	---	surface	ISO 1302	tolerance	ISO 406	projection	product family	CODE
ltr	description	ecm no	dr	date	tolerances unless otherwise specified	MM	PHEC	JP
A	RELEASED	J05-0186	S.O	3/29/05	0.X ±0.3	MM	PRINTED CIRCUIT CONNECTOR	
B	REVISED	J07-0047	S.O	1/25/07	0.XX ±0.3	MM	(CAT.NO.PHEC - - - R-R11_LF)	
C	REVISED	J07-0458	S.O	9/11/07	0.XXX ±0.3	scale N/A	dwg no	sheet 1 of 1 size
					dr S.OKUDAIRA 3/29/05	FCJ	JSC 96359	A3
					enrg S.OKUDAIRA 9/11/07		Customer Drawing	Rev. C
					chr			
					appd. P. Dadao 7/11/07			
sheet index	revision sheet	C						