

AVAILABLE WITH OR WITHOUT
EMI GASKET. P/N 10019396-004
CAN BE PURCHASED SEPARATELY.

AVAILABLE WITH OR WITHOUT
THREADED STAND-OFFS.
P/N 10009634-001 CAN BE
PURCHASED SEPARATELY.
2 REQUIRED PER CONNECTOR.



Copyright FCI.

www.fciconnect.com		surface 3.2 ASME Y14.5	tolerance std ASME Y14.5	projection MM																																																							
TOLERANCES UNLESS OTHERWISE SPECIFIED		ANGULAR	LINEAR	size A4																																																							
		0.X ±.3	0.XX ±.10	Scale 5:2																																																							
		0.XXX ±.050	Product family EyeMax (tm)	ECN 106-0123																																																							
			Spec ref																																																								
<table border="1"> <tr> <th>rev</th> <th>ecn no</th> <th>dr</th> <th>date</th> </tr> <tr> <td>A</td> <td>V03-0845</td> <td>SIP</td> <td>2003/08/13</td> </tr> <tr> <td>B</td> <td>V03-0967</td> <td>DAT</td> <td>2003/09/29</td> </tr> <tr> <td>C</td> <td>V03-1232</td> <td>DAL</td> <td>2004/01/20</td> </tr> <tr> <td>D</td> <td>V04-0460</td> <td>DAL</td> <td>2004/06/08</td> </tr> <tr> <td>E</td> <td>V04-0830</td> <td>TAB</td> <td>2004/08/18</td> </tr> <tr> <td>F</td> <td>V04-0063</td> <td>TAB</td> <td>2005/02/15</td> </tr> <tr> <td>G</td> <td>106-0123</td> <td>HVN</td> <td>2006/07/26</td> </tr> </table>		rev	ecn no	dr	date	A	V03-0845	SIP	2003/08/13	B	V03-0967	DAT	2003/09/29	C	V03-1232	DAL	2004/01/20	D	V04-0460	DAL	2004/06/08	E	V04-0830	TAB	2004/08/18	F	V04-0063	TAB	2005/02/15	G	106-0123	HVN	2006/07/26	<table border="1"> <tr> <td>Dr</td> <td>G. PETERS</td> <td>2003/08/13</td> </tr> <tr> <td>Eng</td> <td>D. BRANN</td> <td>2003/08/13</td> </tr> <tr> <td>Chr</td> <td>HIRAN V N</td> <td>2006/07/26</td> </tr> <tr> <td>Appr</td> <td>HIRAN V N</td> <td>2006/07/26</td> </tr> </table>	Dr	G. PETERS	2003/08/13	Eng	D. BRANN	2003/08/13	Chr	HIRAN V N	2006/07/26	Appr	HIRAN V N	2006/07/26	<table border="1"> <tr> <td>Part no</td> <td>12X R/A THUMBSCREW RECPT.</td> <td>Rev. G</td> </tr> <tr> <td>Assembly</td> <td>ASSEMBLY w/7 KEY SLOTS</td> <td></td> </tr> <tr> <td>Customer</td> <td>10009626</td> <td></td> </tr> <tr> <td>Sheet</td> <td>1 of 8</td> <td></td> </tr> </table>	Part no	12X R/A THUMBSCREW RECPT.	Rev. G	Assembly	ASSEMBLY w/7 KEY SLOTS		Customer	10009626		Sheet	1 of 8	
rev	ecn no	dr	date																																																								
A	V03-0845	SIP	2003/08/13																																																								
B	V03-0967	DAT	2003/09/29																																																								
C	V03-1232	DAL	2004/01/20																																																								
D	V04-0460	DAL	2004/06/08																																																								
E	V04-0830	TAB	2004/08/18																																																								
F	V04-0063	TAB	2005/02/15																																																								
G	106-0123	HVN	2006/07/26																																																								
Dr	G. PETERS	2003/08/13																																																									
Eng	D. BRANN	2003/08/13																																																									
Chr	HIRAN V N	2006/07/26																																																									
Appr	HIRAN V N	2006/07/26																																																									
Part no	12X R/A THUMBSCREW RECPT.	Rev. G																																																									
Assembly	ASSEMBLY w/7 KEY SLOTS																																																										
Customer	10009626																																																										
Sheet	1 of 8																																																										



Copyright FCI.

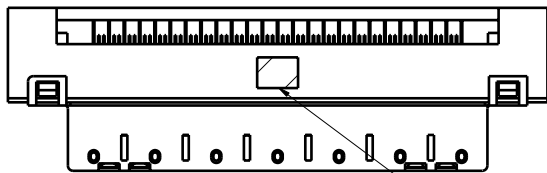

CROSS HATCH AREA IS FOR VACUUM PICK & PLACE, REF. ONLY.

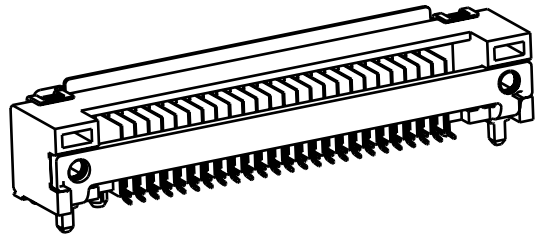

SCALE 2:1

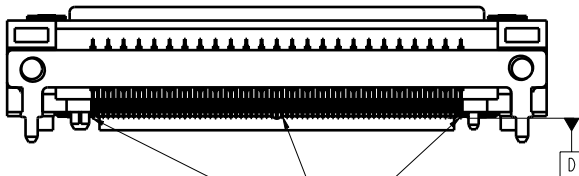

0.13 D

COPLANARITY MEASUREMENT TO BE TAKEN AT BOTTOM MOST POINT ON CONTACT TAILS
COPLANARITY ZONE IS BELOW DATUM D

www.fciconnect.com		surface 3.2 ASME Y14.5		Tolerance std ASME Y14.5		projection MM	
TOLERANCES UNLESS OTHERWISE SPECIFIED		ANGULAR		0.X ±.3		size A4 Scale 2:1	
Dr G. PETERS	2003/08/13	LINEAR		0.XX ±.10		ECN 106-0123	
Eng D. BRANN	2003/08/13	0° ±°		0.XXX ±.050		Product family EyeMax (tm)	
Chr HIRAN V N	2006/07/26	Product family EyeMax (tm)		Spec ref		-	
Appr HIRAN V N	2006/07/26	-		-		-	
FCI		12X R/A THUMBSCREW RECPT. ASSEMBLY w/7 KEY SLOTS		part no 10009626		Rev. G	
catalog no		CUSTOMER		sheet 2 of 8			

REV. 1 2006-06-17

PDM: Rev:G

STATUS: Released

Printed: Jan 28, 2008

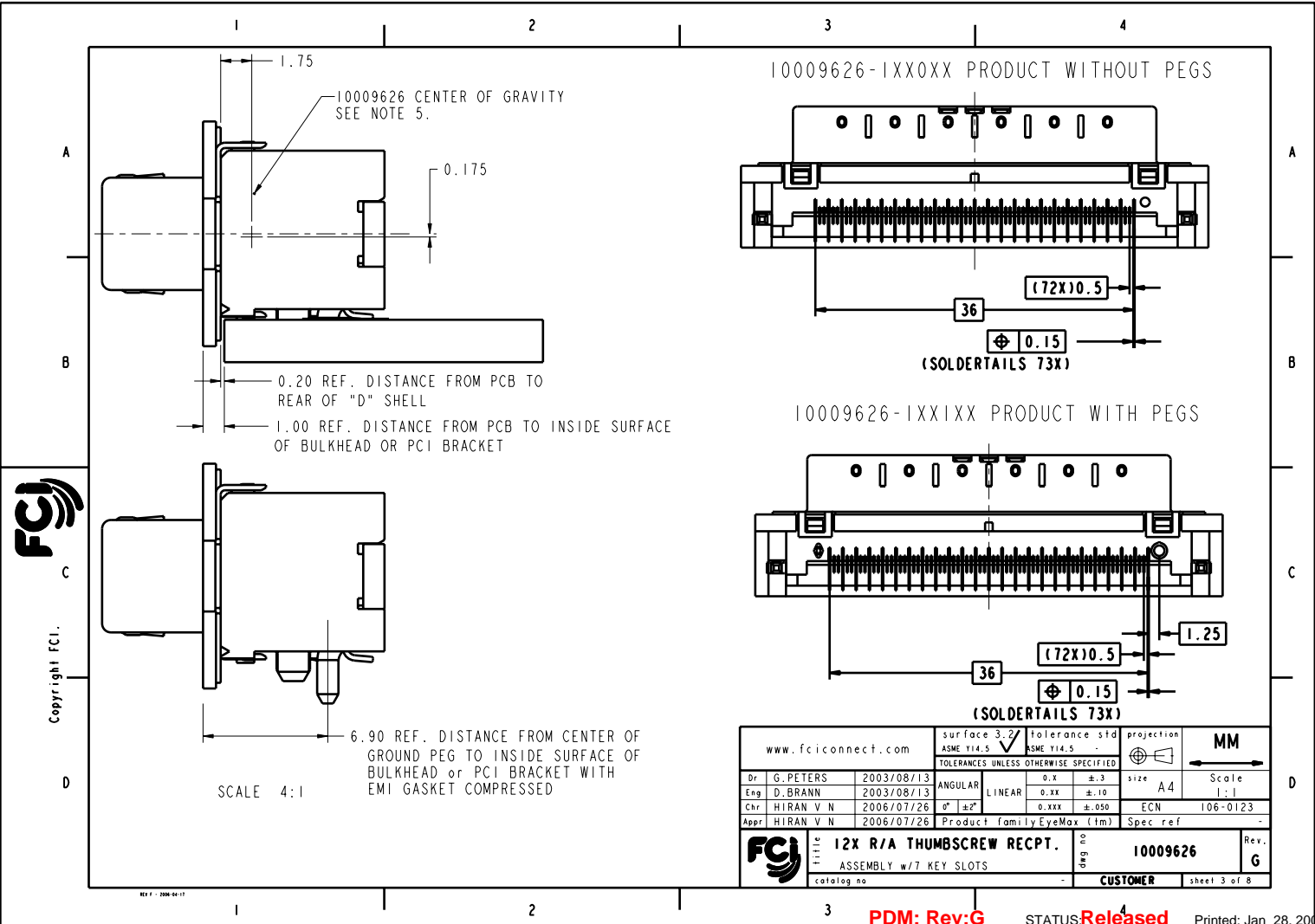

Copyright FCI.

www.fciconnect.com		surface 3.2 ASME Y14.5	Tolerance std ASME Y14.5	projection MM
TOLERANCES UNLESS OTHERWISE SPECIFIED				
Dr	G. PETERS	2003/08/13	ANGULAR	0.X ±.3
Eng	D. BRANN	2003/08/13	LINEAR	0.XX ±.10
Chr	HIRAN V N	2006/07/26	0" ±"	0.XXX ±.050
Appr	HIRAN V N	2006/07/26	Product family	EyeMax (tm)
size		A4		
ECN		106-0123		
Spec ref				
		12X R/A THUMBSCREW RECPT. ASSEMBLY w/7 KEY SLOTS		10009626 Rev. G
catalog no.		CUSTOMER		sheet 3 of 8



Copyright FCJ.

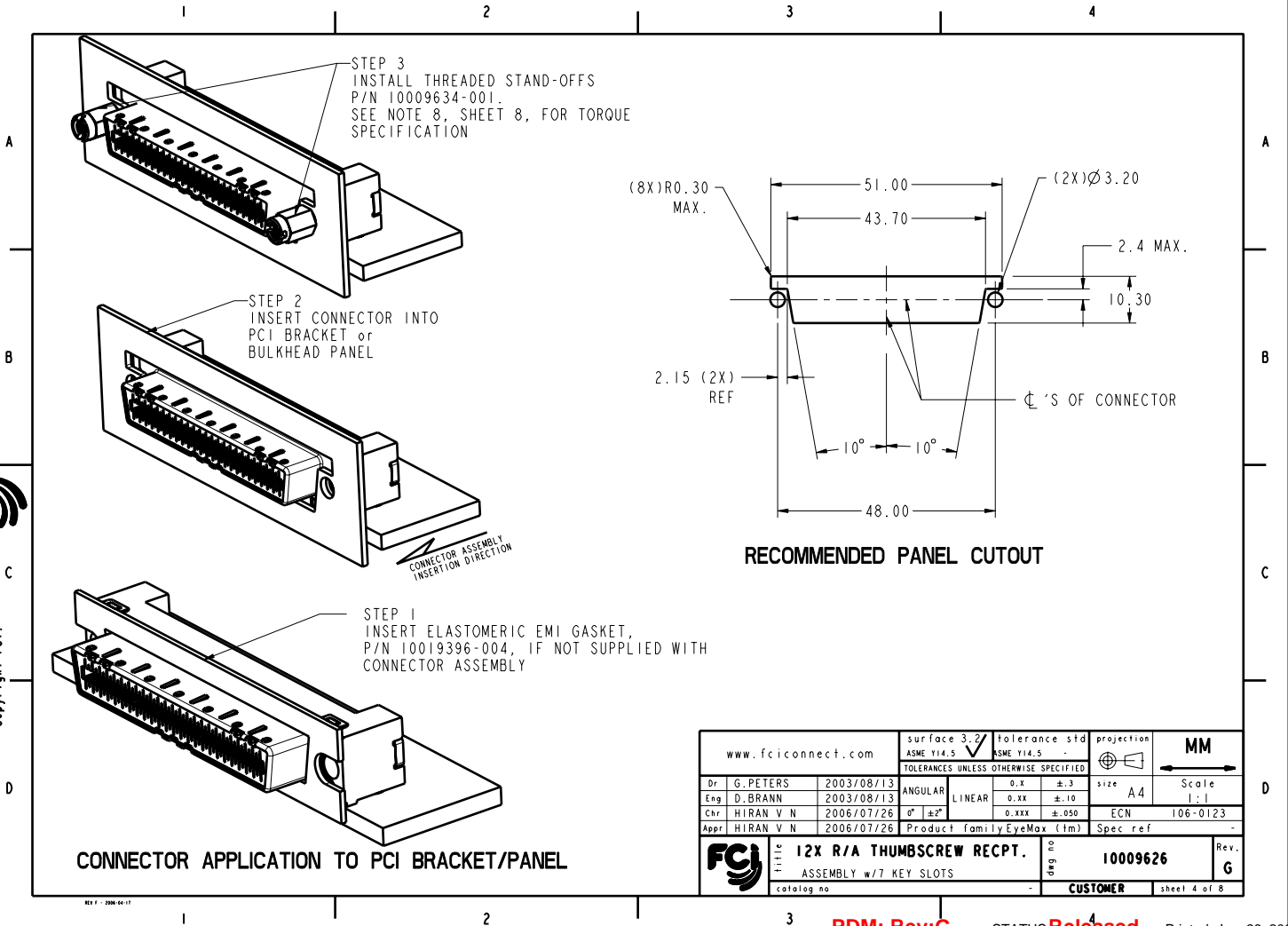

www.fciconnect.com		surface 3.2 ASME Y14.5	Tolerance std ASME Y14.5	projection MM
TOLERANCES UNLESS OTHERWISE SPECIFIED		0.X ±.3	size A4	Scale 1:1
Dr G. PETERS	2003/08/13	ANGULAR	0.XX ±.10	ECN 106-0123
Eng D. BRANN	2003/08/13	LINEAR	0.XXX ±.050	Spec ref -
Chr HIRAN V N	2006/07/26	0° ±°	Product family EyeMax (tm)	
Appr HIRAN V N	2006/07/26			
	12X R/A THUMBSCREW RECPT. ASSEMBLY w/7 KEY SLOTS	part no	10009626	Rev. G
catalog no		CUSTOMER	sheet 4 of 8	

PDM: Rev:G

STATUS: Released

Printed: Jan 28, 2008



Copyright FCJ.

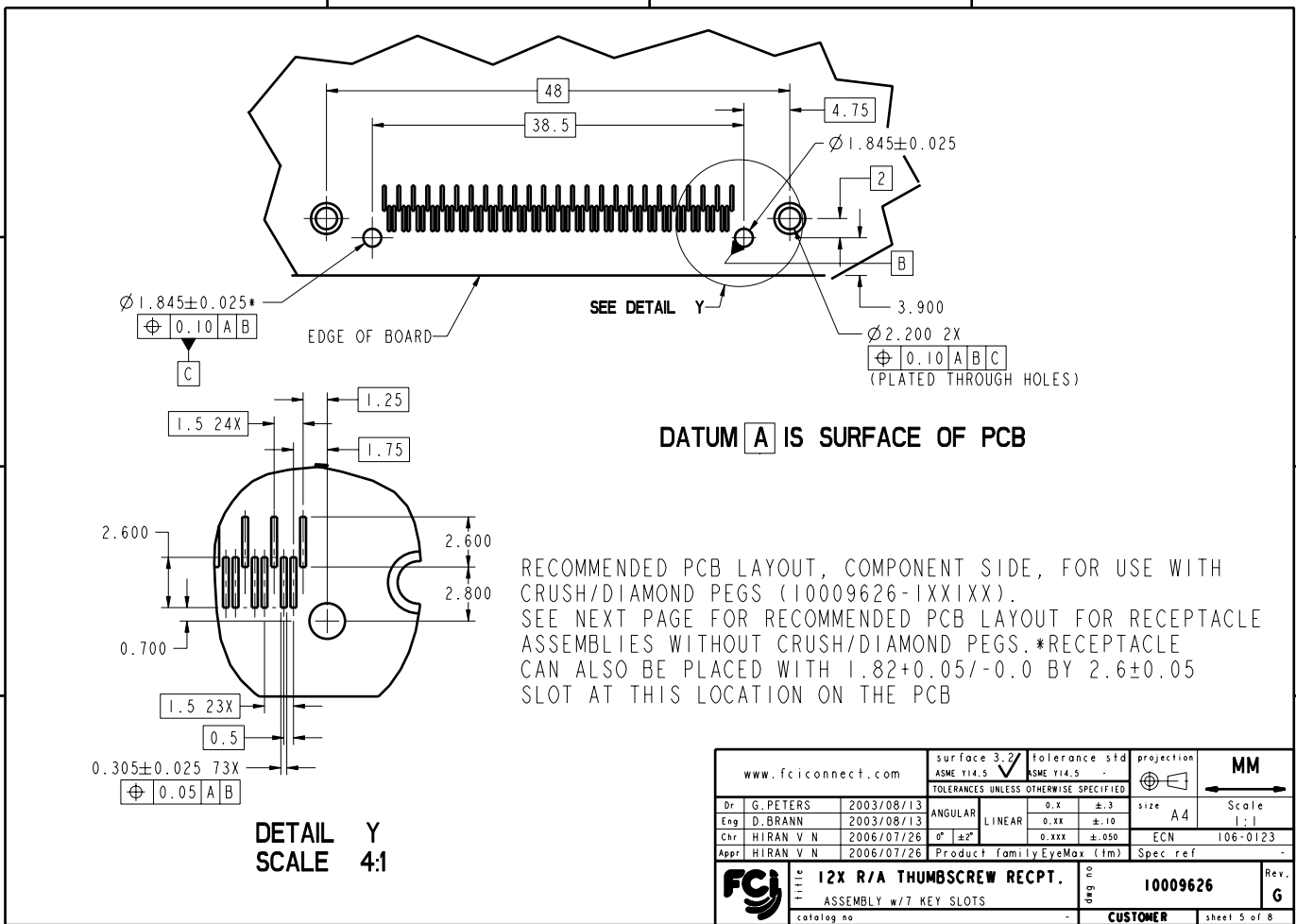

DATUM A IS SURFACE OF PCB

RECOMMENDED PCB LAYOUT, COMPONENT SIDE, FOR USE WITH CRUSH/DIAMOND PEGS (10009626-1XX1XX).
 SEE NEXT PAGE FOR RECOMMENDED PCB LAYOUT FOR RECEPTACLE ASSEMBLIES WITHOUT CRUSH/DIAMOND PEGS. *RECEPTACLE CAN ALSO BE PLACED WITH 1.82±0.05/-0.0 BY 2.6±0.05 SLOT AT THIS LOCATION ON THE PCB

www.fciconnect.com		surface 3.2 ASME Y14.5	Tolerance std ASME Y14.5	projection MM
TOLERANCES UNLESS OTHERWISE SPECIFIED		0.X ±.3	size A4	Scale 1:1
Dr G. PETERS	2003/08/13	ANGULAR	0.XX ±.10	ECN 106-0123
Eng D. BRANN	2003/08/13	LINEAR	0.XXX ±.050	Spec ref -
Chr HIRAN V N	2006/07/26	0° ±2°	Product family EyeMax (tm)	
Appr HIRAN V N	2006/07/26			
	12X R/A THUMBSCREW RECPT. ASSEMBLY w/7 KEY SLOTS	part no	10009626	Rev. G
catalog no		CUSTOMER		sheet 5 of 8

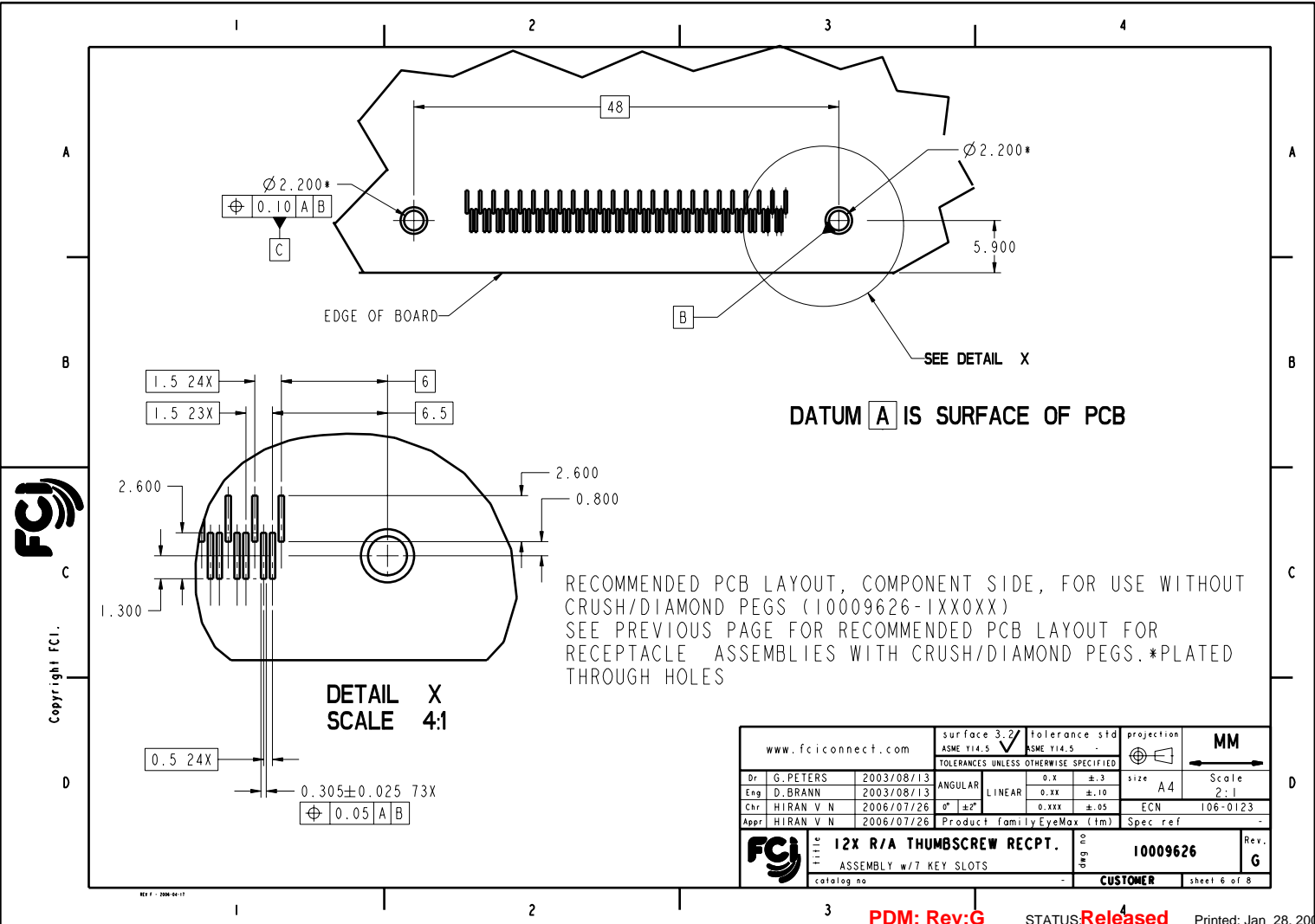

Copyright FCJ.

www.fciconnect.com		surface 3.2 ASME Y14.5	Tolerance std ASME Y14.5	projection MM
TOLERANCES UNLESS OTHERWISE SPECIFIED		0.X ±.3	size A4	Scale 2:1
Dr G. PETERS	2003/08/13	ANGULAR	LINEAR	ECN 106-0123
Eng D. BRANN	2003/08/13	0° ±°	0.xxx ±.05	Product family EyeMax (tm)
Chr HIRAN V N	2006/07/26	0.305±0.025 73X	0.05 A B	Spec ref
Appr HIRAN V N	2006/07/26	12X R/A THUMBSCREW RECPT. ASSEMBLY w/7 KEY SLOTS		10009626
catalog no		CUSTOMER		Rev. G



Copyright FCJ.

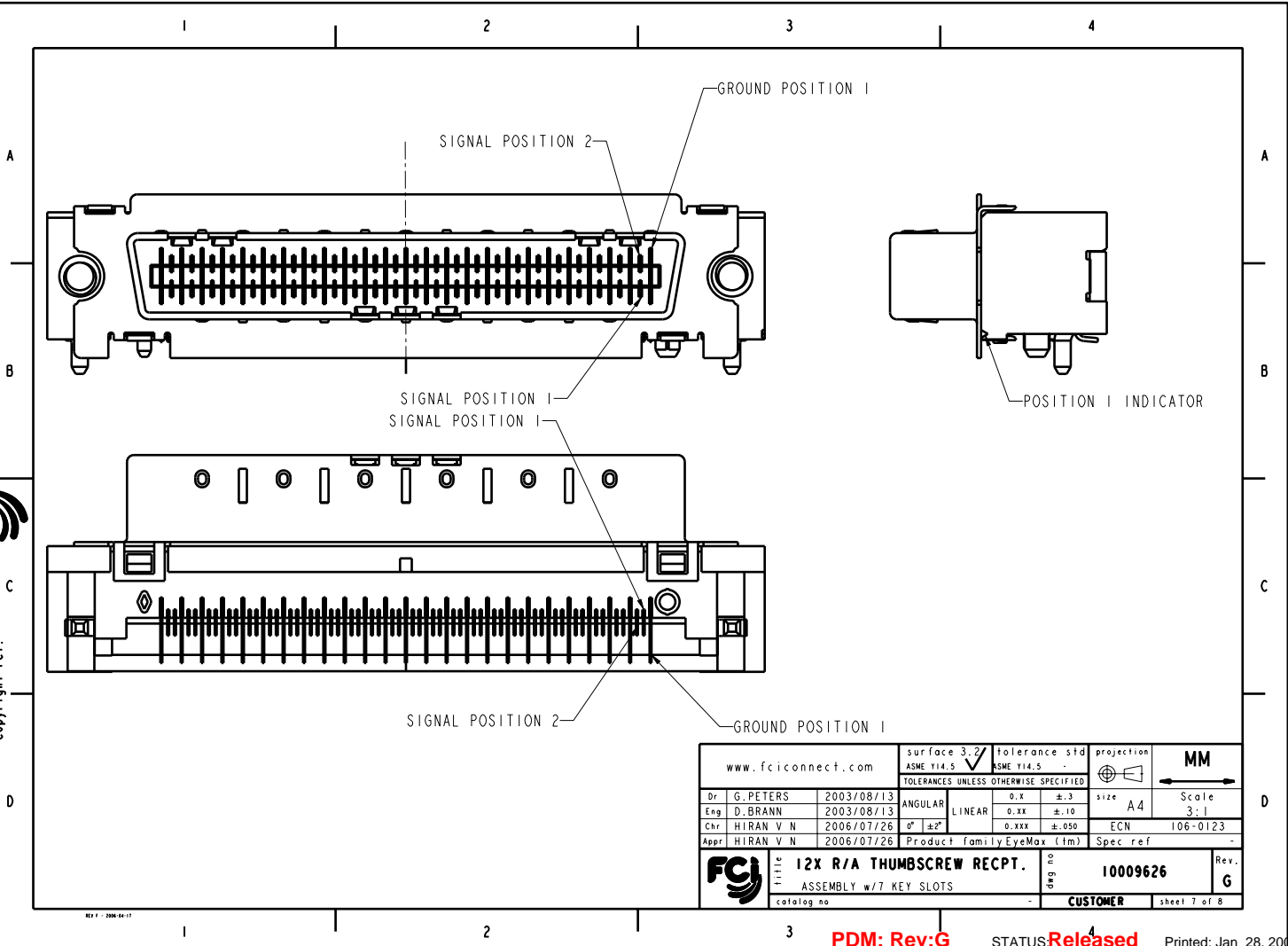

www.fciconnect.com		surface 3.2 ASME Y14.5	Tolerance std ASME Y14.5	projection MM
TOLERANCES UNLESS OTHERWISE SPECIFIED		0.x ±.3	0.xx ±.10	size A4
Dr G. PETERS	2003/08/13	ANGULAR	0.xxx ±.050	Scale 3:1
Eng D. BRANN	2003/08/13	LINEAR		ECN 106-0123
Chr HIRAN V N	2006/07/26	0° ±2°		Spec ref -
Appr HIRAN V N	2006/07/26	Product family EyeMax (tm)		
	12X R/A THUMBSCREW RECEPT.	cat no	10009626	Rev. G
	ASSEMBLY w/7 KEY SLOTS		CUSTOMER	sheet 7 of 8

PRODUCT NUMBER

10009626-1XXXX

CONNECTOR NOTES:

- ① HOUSING MATERIAL: UL94 V-0 LCP RESIN.
SIGNAL PIN MATERIAL: COPPER ALLOY.
GROUND CONTACT MATERIAL: COPPER ALLOY.
- ② PLATING: LEAD FREE SOLDER TAILS 2µm (80µin) MIN MATTE
TIN OVER 1.27µm (50µin) MIN NICKEL UNDERPLATE.
- ③ P/N AND DATE CODE TO APPEAR ON THIS SURFACE.
- 4. PRODUCT SPECIFICATION GS-12-209.
APPLICATION SPECIFICATION GS-20-025
- 5. CONNECTOR WEIGHT = 11.06 grams
- 6. PACKAGING SPECIFICATION GS-14-794. PACKAGING OF LEAD FREE
PRODUCTS MEETS LABELING AND PACKAGING SPECIFICATION GS-14-920.
- 7. MAXIMUM PANEL THICKNESS 1.70mm.
- ⑧ MAXIMUM TORQUE 0.45 N-m (4 lbf-in).

PCB NOTES:

- 9. ALL DIMENSIONS ARE BASIC UNLESS OTHERWISE SPECIFIED.
- 10. ALL HOLE DIAMETERS ARE FINISHED HOLE SIZE
- 11. MATES WITH EYEMAX® PLUG 58443 (WITHOUT PCB), 58638 (WITH UNEQUALIZED PCB) OR 10026694 (WITH EQUALIZED PCB).
- 12. LEAD FREE PRODUCTS MEET EUROPEAN UNION DIRECTIVES AND OTHER COUNTRY REGULATIONS AS DESCRIBED IN GS-22-008.
- 13. THE HOUSING WILL WITHSTAND EXPOSURE TO 260°C PEAK TEMPERATURE FOR 15 SECONDS IN A CONVECTION, INFRARED OR VAPOR PHASE REFLOW OVEN.

10009626-1XXXXXXYY

- SOLDERTAIL PLATING
BLANK-TIN/LEAD
LF-LEAD FREE (SEE NOTE 2)
- KEYING OPTIONS
0-NONE
- PACKAGING
1-TAPE & REEL
2-TRAY
3-TAPE & REEL WITH THREADED STAND-OFFS INCLUDED (PACKAGED SEPARATELY). 2 PER CONNECTOR.
4-TRAY WITH THREADED STAND-OFFS INCLUDED (PACKAGED SEPARATELY). 2 PER CONNECTOR.
- PEGS
0-NONE
1-CRUSH/DIAMOND PEGS
- PCB THICKNESS
1-1.6mm
2-2.4mm
3-4.0mm
- EMI GASKET
0- WITH GASKET
1- WITHOUT GASKET
- GOLD OVER NICKEL IN CONTACT AREA

PRODUCT NUMBER	BOARD THICKNESS	DIM A
10009626-1X1XXX	1.6mm	2.3mm
10009626-1X2XXX	2.4mm	3.1mm
10009626-1X3XXX	4.0mm	4.7mm

www.fciconnect.com		surface 3.2 ASME Y14.5	Tolerance std ASME Y14.5	projection MM
TOLERANCES UNLESS OTHERWISE SPECIFIED		0.X ±.3	size A4	Scale 1:1
Dr G. PETERS	2003/08/13	ANGULAR	0.XX ±.10	ECN 106-0123
Eng D. BRANN	2003/08/13	LINEAR	0.XXX ±.050	Spec ref -
Chr HIRAN V N	2006/07/26	Product family EyeMax (tm)		
Appr HIRAN V N	2006/07/26			
	12X R/A THUMBSCREW RECPT. ASSEMBLY w/7 KEY SLOTS	part no	10009626	Rev. G
catalog no		CUSTOMER	sheet 8 of 8	



Copyright FCI.

REV. 2006-02-17

PDM: Rev:G

STATUS: Released

Printed: Jan 28, 2008