

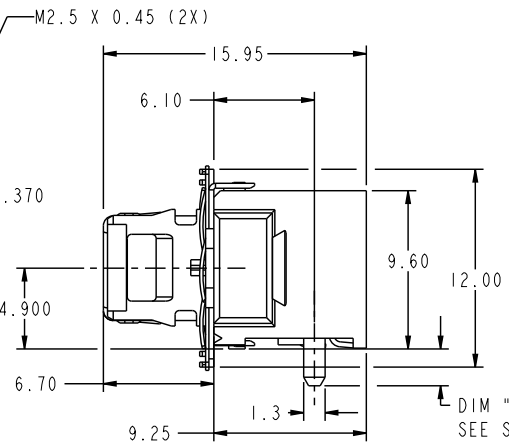

Copyright FCJ.

PRODUCT NUMBER  
58369-11XXXX

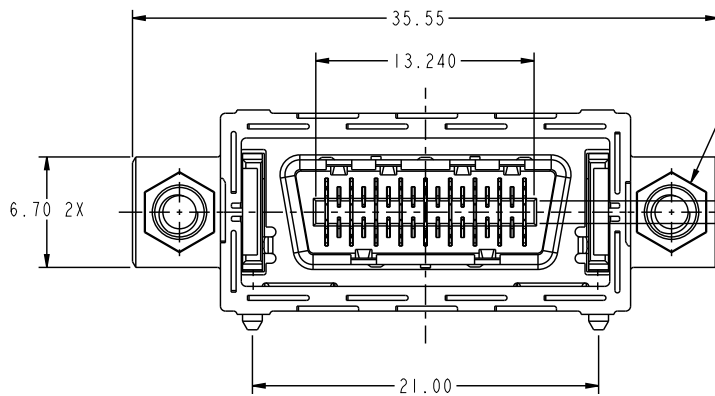
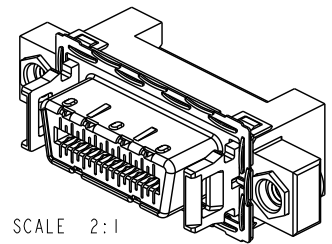
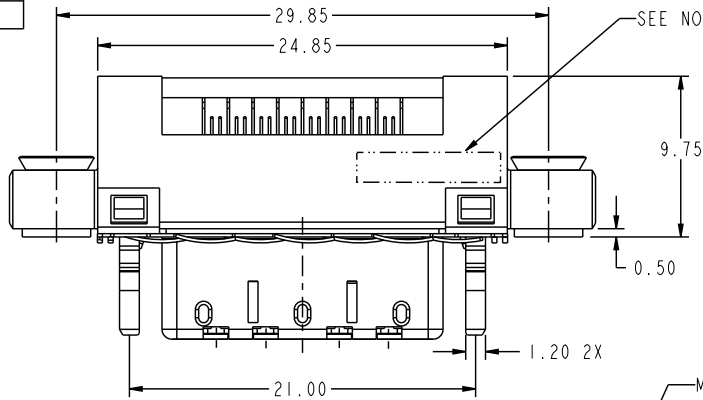

rev	ecn no	dr	date
L	109-0115	RPK	2009-06-25
F	V03-0087	GIP	2003-03-14
G	V03-0430	OAI	2004-06-07
H	V05-0063	TAB	2005-02-14
J	106-0123	HVN	2006-07-26
K	107-0024	HVN	2006-02-26

www.fciconnect.com		surface 3.2 ASME Y14.5	tolerance std ASME Y14.5	projection MM
Dr R. DRAGG00 2002-01-07		ANGULAR	0.x ±.30	size A4 Scale 3:1
Eng S. OLSON 2001-09-11		LINEAR	0.xx ±.10	ECN 109-0115
Chr HIRAN V N 2006-02-26		0° ±2°	0.xxx ±.050	Spec ref -
Appr HIRAN V N 2006-02-26		Product family EyeMax (1m)		
		4X R/A RECP. ASSEMBLY		Rev. L
w/MOUNTING TABS		eng no	58369	
catalog no		CUSTOMER		sheet 1 of 9

REV F - 2004-04-07

3PDM: Rev:L

STATUS Released

4 Printed: Apr 21, 2010



Copyright FCJ.

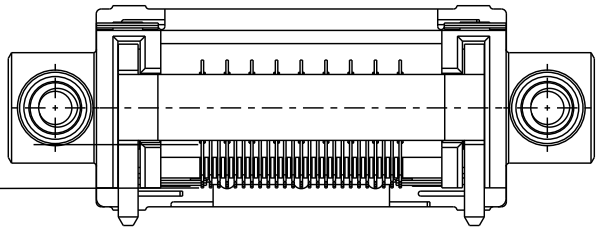

COPLANARITY MEASUREMENT TO BE TAKEN AT BOTTOM MOST POINT OF CONTACT TAILS

COPLANARITY ZONE IS BELOW DATUM D

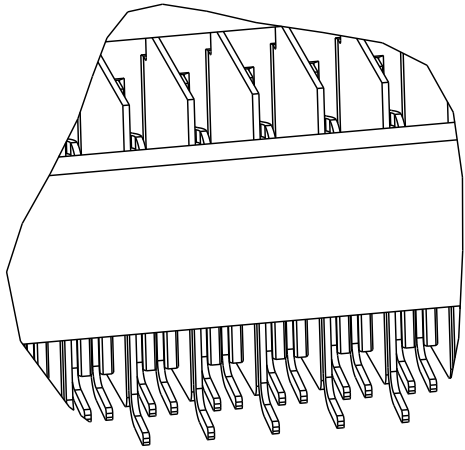

SCALE 8:1

www.fciconnect.com		surface 3.2/ ASME Y14.5		tolerance std ASME Y14.5		projection		MM	
TOLERANCES UNLESS OTHERWISE SPECIFIED									
Dr	R. DRAGGOO	2002-01-07	ANGULAR	LINEAR	0.x	±.30	size	A4	Scale 3:1
Eng	S. OLSON	2001-09-11			0.xx	±.10			
Chr	HIRAN V N	2006-02-26	0°	±2°	0.xxx	±.050	ECN	109-0115	
Appr	HIRAN V N	2006-02-26	Product family EyeMax (1m)			Spec ref			
		4X R/A RECPT. ASSEMBLY				58369		Rev. L	
w/MOUNTING TABS		catalog no		CUSTOMER		sheet 2 of 9			

REV F - 2004-04-07

3PDM: Rev:L

STATUS Released

4 Printed: Apr 21, 2010



Copyright FCJ.

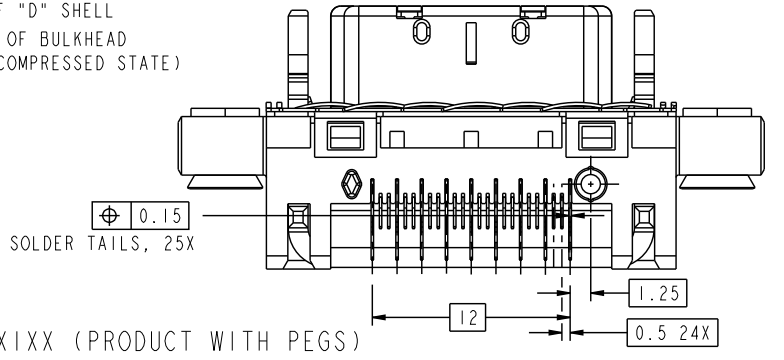
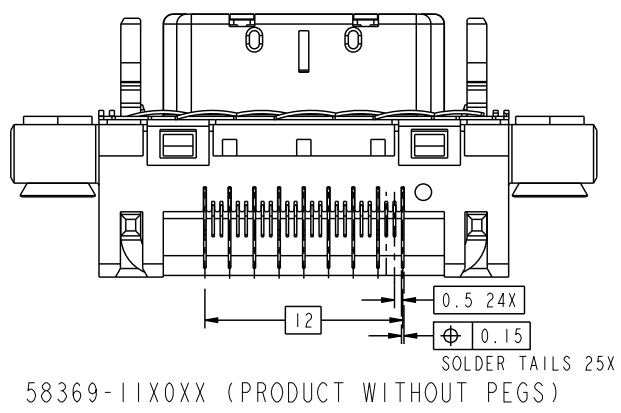
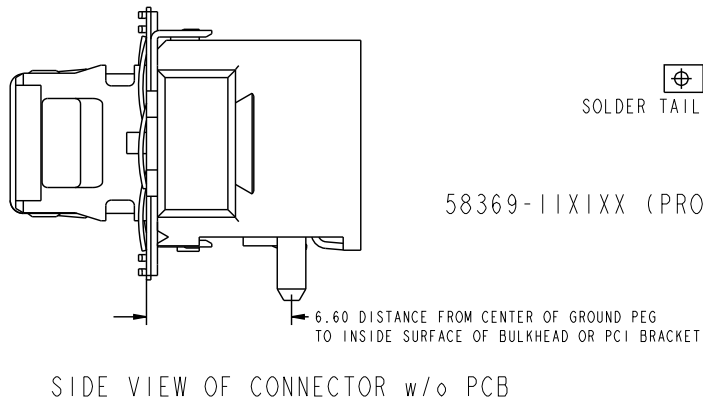
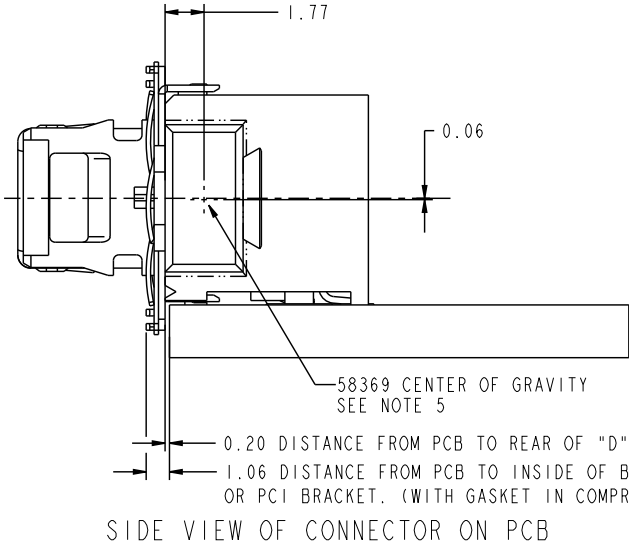

www.fciconnect.com		surface 3.2/ASME Y14.5	tolerance std ASME Y14.5	projection	MM
TOLERANCES UNLESS OTHERWISE SPECIFIED		0.x ±.30	0.xx ±.10	size A4	Scale 4:1
Dr R. DRAGGOO	2002-01-07	ANGULAR	LINEAR	ECN 109-0115	
Eng S. OLSON	2001-09-11	0° ±2°	0.xxx ±.050	Spec ref	-
Chr HIRAN V N	2006-02-26	Product family EyeMax (1m)			
Appr HIRAN V N	2006-02-26				
FCJ 4X R/A RECP. ASSEMBLY		eng no	58369	Rev.	L
w/MOUNTING TABS		catalog no	CUSTOMER	sheet 3 of 9	

REV F - 2004-04-07



Copyright FCI.

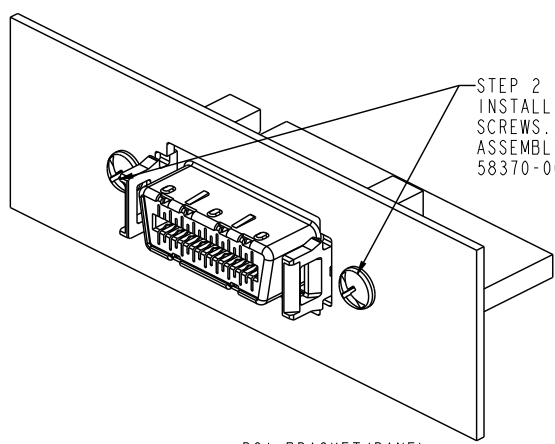

STEP 2  
INSTALL TWO M2.5 PANEL MOUNTING  
SCREWS. (NOT SUPPLIED WITH CONNECTOR  
ASSEMBLY) SEE PRINT 58370 FOR P/N  
58370-001

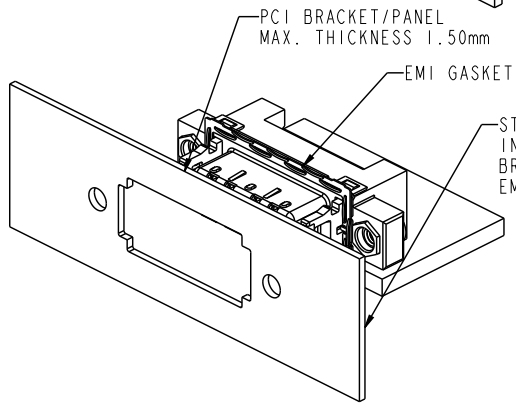

STEP 1  
INSERT CONNECTOR INTO PCI  
BRACKET/PANEL COMPRESSING  
EMI GASKET

PCI BRACKET/PANEL  
MAX. THICKNESS 1.50mm

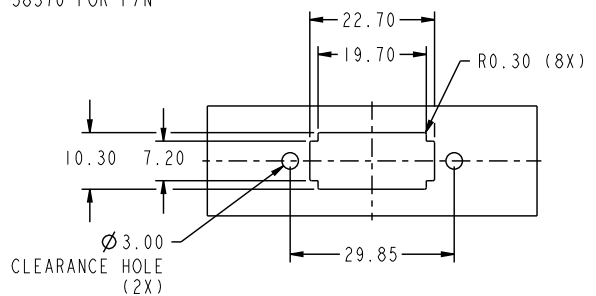

SCALE 1:1  
PANEL CUTOUT

CONNECTOR APPLICATION TO PCI BRACKET/PANEL

www.fciconnect.com		surface 3.2/ ASME Y14.5	tolerance std ASME Y14.5	projection MM
TOLERANCES UNLESS OTHERWISE SPECIFIED				
Dr	R. DRAGGOO	2002-01-07	ANGULAR	LINEAR
Eng	S. OLSON	2001-09-11	0.x	±.30
Chr	HIRAN V N	2006-02-26	0.xx	±.10
Appr	HIRAN V N	2006-02-26	0.xxx	±.050
Product family		EyeMax (1m)	ECN	109-0115
Spec ref		-		
FCJ		4X R/A RECPT. ASSEMBLY		Rev. L
w/MOUNTING TABS		eng no	58369	
catalog no		CUSTOMER		sheet 4 of 9

REV F - 2004-04-07



Copyright FCJ.

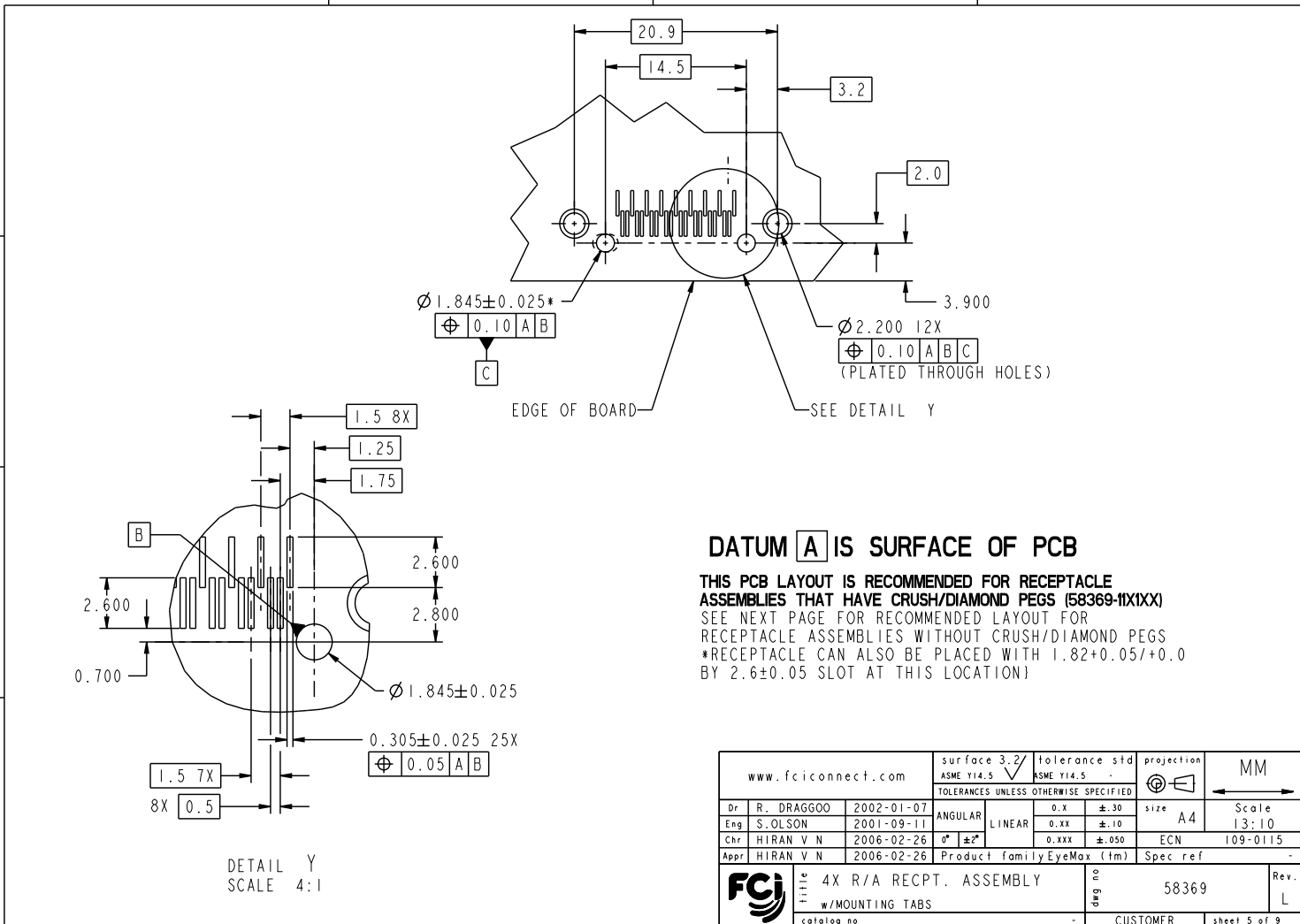

REV F - 2004-04-07



Copyright FCI.

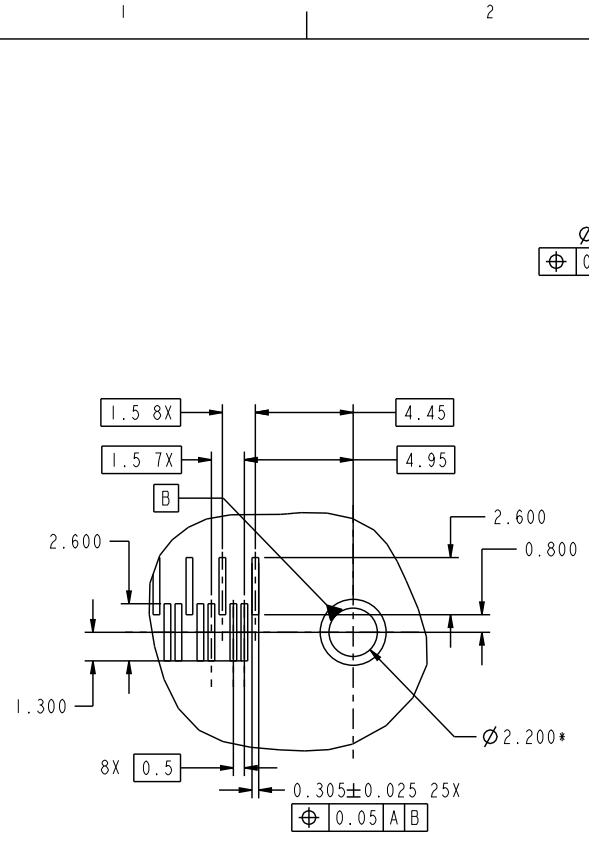

DETAIL X  
SCALE 4:1

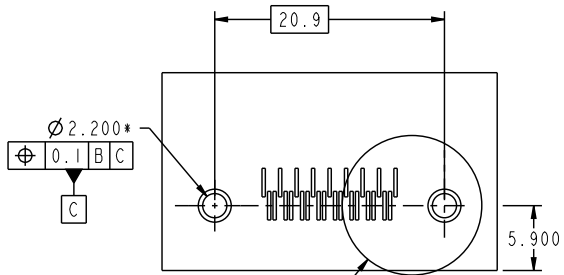

SEE DETAIL X

DATUM A IS SURFACE OF PCB

THIS PCB LAYOUT IS RECOMMENDED FOR RECEPTACLE ASSEMBLIES THAT DO NOT HAVE CRUSH/DIAMOND PEGS (58369-11X0XX) SEE PREVIOUS PAGE FOR RECOMMENDED LAYOUT FOR RECEPTACLE ASSEMBLIES WITH CRUSH/DIAMOND PEGS \*PLATED THROUGH HOLES

www.fciconnect.com		surface 3.2/ASME Y14.5	tolerance std ASME Y14.5	projection	MM
TOLERANCES UNLESS OTHERWISE SPECIFIED					
Dr	R. DRAGGOO	2002-01-07	ANGULAR	0.x ±.30	size A4
Eng	S. OLSON	2001-09-11	LINEAR	0.xx ±.10	Scale 13:10
Chr	HIRAN V N	2006-02-26	0° ±2°	0.xxx ±.050	ECN 109-0115
Appr	HIRAN V N	2006-02-26	Product family EyeMax (1m)	Spec ref	-
FCJ 4X R/A RECPT. ASSEMBLY			eng no	58369	Rev. L
w/MOUNTING TABS			customer	sheet 6 of 9	
catalog no					

REV F - 2004-04-07

3PDM: Rev:L

STATUS Released

4 Printed: Apr 21, 2010



Copyright FCI.

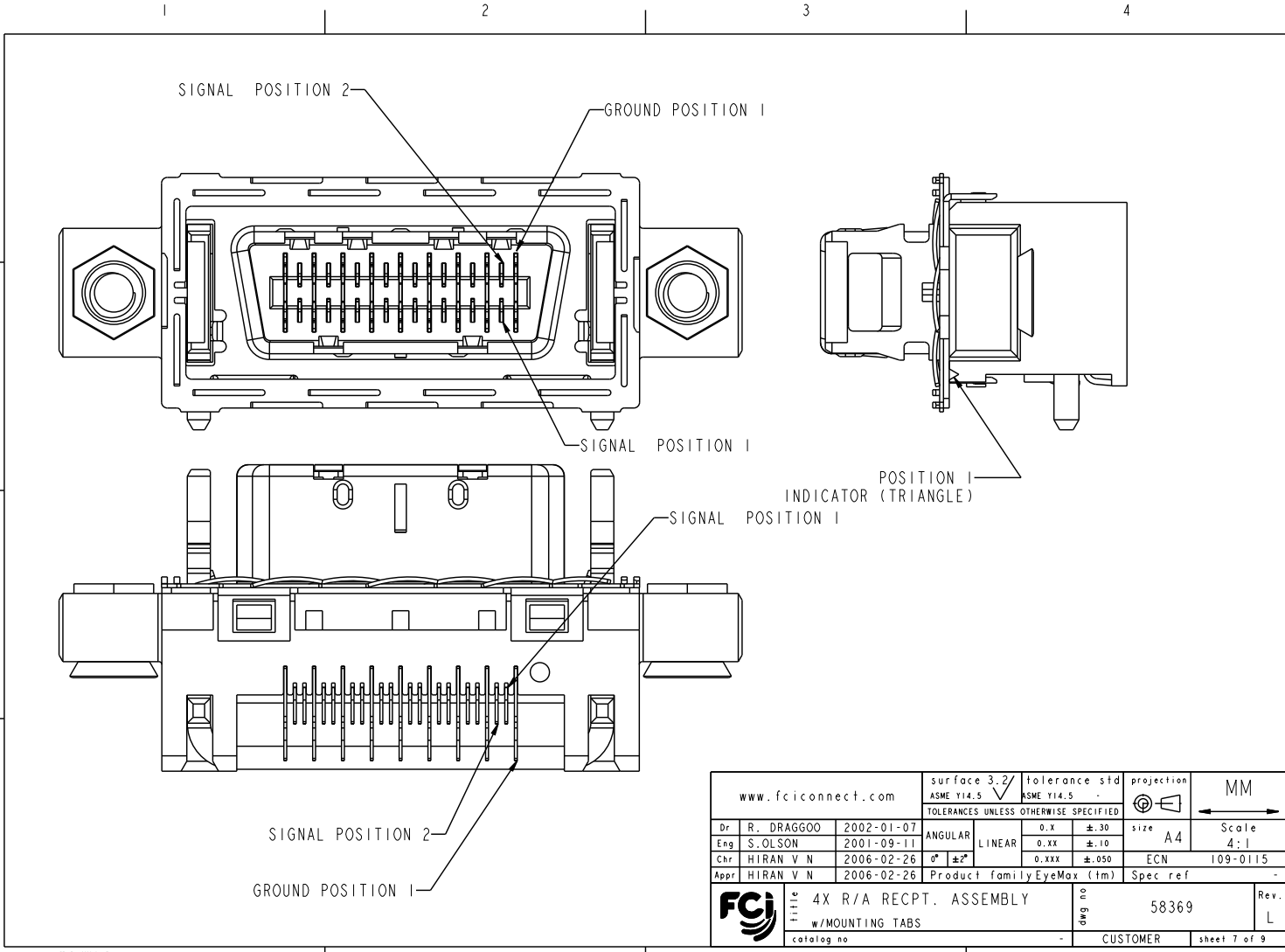

www.fciconnect.com		surface 3.2/ASME Y14.5	tolerance std ASME Y14.5	projection	MM
TOLERANCES UNLESS OTHERWISE SPECIFIED					
Dr	R. DRAGG00	2002-01-07	ANGULAR	0.x ±.30	size A4 Scale 4:1
Eng	S. OLSON	2001-09-11	LINEAR	0.xx ±.10	ECN 109-0115
Chr	HIRAN V N	2006-02-26	0° ±*	0.xxx ±.050	Spec ref -
Appr	HIRAN V N	2006-02-26	Product family	EyeMax (1m)	
FCJ		4X R/A RECP. ASSEMBLY		eng no	58369
		w/MOUNTING TABS			Rev. L
catalog no		CUSTOMER		sheet 7 of 9	

REV F - 2004-04-07

3PDM: Rev:L STATUS Released 4 Printed: Apr 21, 2010



Copyright FCJ.

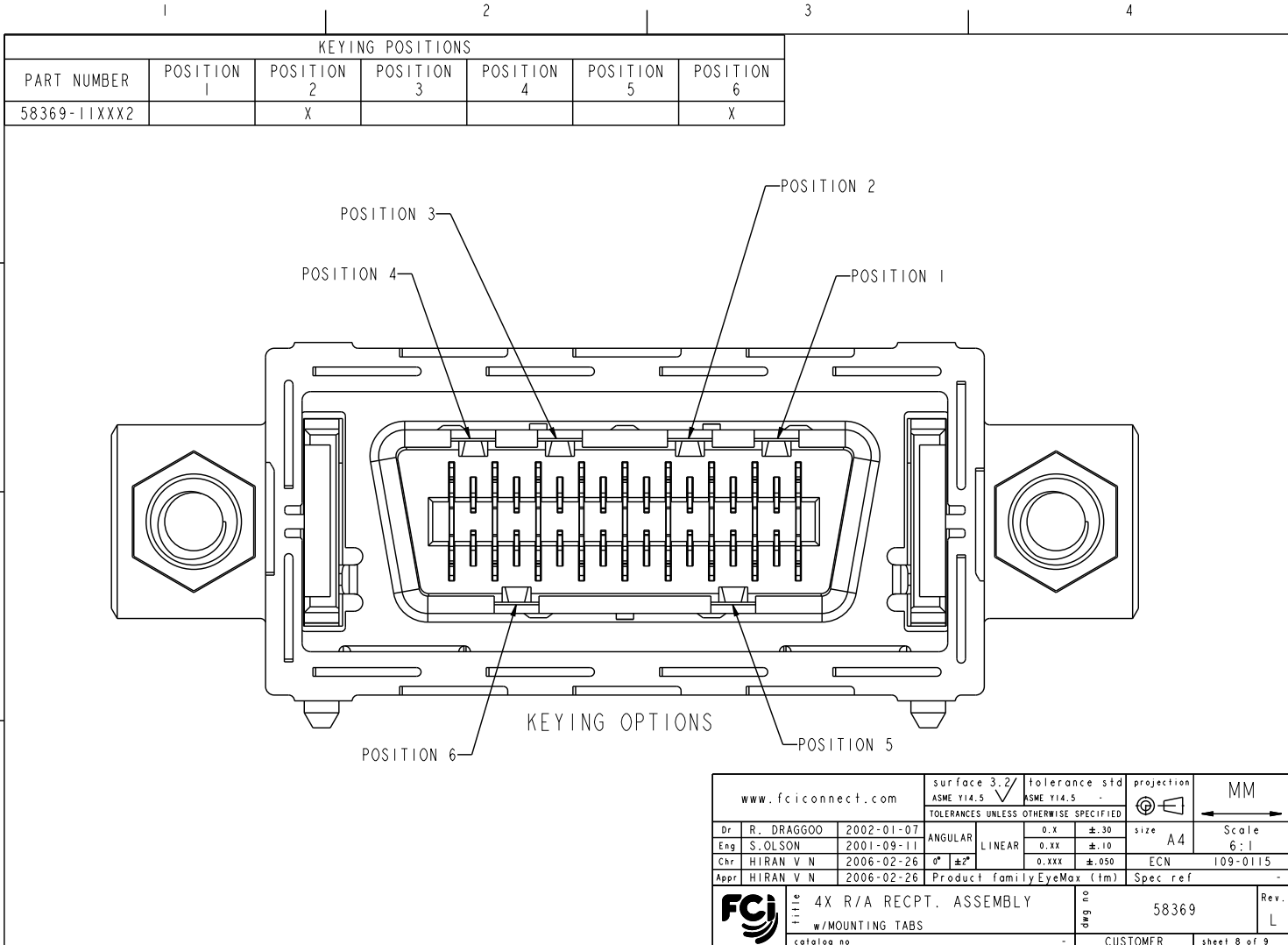

www.fciconnect.com		surface 3.2/ASME Y14.5	tolerance std ASME Y14.5	projection	MM
TOLERANCES UNLESS OTHERWISE SPECIFIED					
Dr R. DRAGGOO	2002-01-07	ANGULAR	LINEAR	0.x ±.30	size A4 Scale 6:1
Eng S. OLSON	2001-09-11	0° ±*		0.xx ±.10	ECN 109-0115
Chr HIRAN V N	2006-02-26			0.xxx ±.050	Spec ref -
Appr HIRAN V N	2006-02-26	Product family EyeMax (1m)		-	
		4X R/A RECPT. ASSEMBLY		eng no 58369	Rev. L
w/MOUNTING TABS		catalog no		CUSTOMER	sheet 8 of 9

REV F - 2004-04-07

3PDM: Rev:L STATUS Released 4 Printed: Apr 21, 2010



58369-11XXXXY

SOLDERTAIL PLATING  
BLANK-TIN/LEAD  
LF-LEAD FREE (SEE NOTE 2)

KEYING OPTIONS, SEE SHEET 8  
0-NONE  
2-CUSTOM

PACKAGING  
1-TAPE & REEL  
2-TRAY

PEGS  
0-NO PEGS  
1-CRUSH/DIAMOND PEG

PCB THICKNESS  
1-1.6mm  
2-2.4mm  
3-4.0mm

EMI GASKET  
1-WITH GASKET

INTERFACE PLATING  
1-Au over Ni

PRODUCT NUMBER	BOARD THICKNESS	DIM A
58369-111XXX	1.6mm	2.3
58369-112XXX	2.4mm	3.1
58369-113XXX	4.0mm	4.7

NOTES: )

- ① HOUSING MATERIAL: UL94 V-O LCP RESIN.  
SIGNAL PIN MATERIAL: COPPER ALLOY.  
GROUND CONTACT MATERIAL: COPPER ALLOY.
- ② PLATING: LEAD FREE SOLDER TAILS 2 $\mu$ m (80 $\mu$ in) MIN MATTE TIN  
OVER 1.27 $\mu$ m (50 $\mu$ in) MIN NICKEL UNDERPLATE.
- ③ P/N AND DATE CODE TO APPEAR ON THIS SURFACE.
4. PRODUCT SPECIFICATION GS-12-209.
5. CONNECTOR WEIGHT= 7.06 grams
6. APPLICATION SPECIFICATION: GS-20-025
7. PACKAGING SPECIFICATION GS-14-794. PACKAGING OF LEAD FREE PRODUCTS MEETS LABELING AND PACKAGING SPECIFICATION GS-14-920.
8. ALL DIMENSIONS ON PCB'S ARE BASIC UNLESS OTHERWISE SPECIFIED
9. ALL HOLE DIAMETERS ON PCB'S ARE FINISHED HOLE SIZE
- ⑩ AREA ON TOP OF CONNECTOR IS FLAT & SMOOTH AND CAN BE USED FOR VACUUM PICK & PLACE.
11. MATES WITH EYEMAX<sup>®</sup> PLUG 58443 (WITHOUT PCB), 58638 (WITH UNEQUALIZED PCB) OR 10026692 (WITH EQUALIZED PCB).
12. RECOMMENDED SCREW TORQUE IS 0.15Nm (1.33 in-lbs).
13. LEAD FREE PRODUCTS MEET EUROPEAN UNION DIRECTIVES AND OTHER COUNTRY REGULATIONS AS DESCRIBED IN GS-22-008.
14. THE HOUSING WILL WITHSTAND EXPOSURE TO 260°C PEAK TEMPERATURE FOR 15 SECONDS IN A CONVECTION, INFRARED OR VAPOR PHASE REFLOW OVEN.

www.fciconnect.com		surface 3.2/ ASME Y14.5	tolerance std ASME Y14.5	projection	MM
TOLERANCES UNLESS OTHERWISE SPECIFIED					
Dr	R. DRAGGOO	2002-01-07	ANGULAR	LINEAR	0.x ±.30 0.xx ±.10 0.xxx ±.050
Eng	S. OLSON	2001-09-11	0° ±*		size A4 Scale 13:10
Chr	HIRAN V N	2006-02-26	Product family	EyeMax (1m)	ECN 109-0115
Appr	HIRAN V N	2006-02-26	Spec ref		-
FCJ		4X R/A RECPT. ASSEMBLY		58369	Rev. L
w/MOUNTING TABS		CUSTOMER		sheet 9 of 9	

REV F - 2004-04-07

3PDM: Rev:L

STATUS Released 4 Printed: Apr 21, 2010



Copyright FCJ.