

EDP NO. 39-00-00\*\* SD-5556\*\*\*\*

MM DIMENSIONS IN METRIC DO NOT SCALE DRAWING

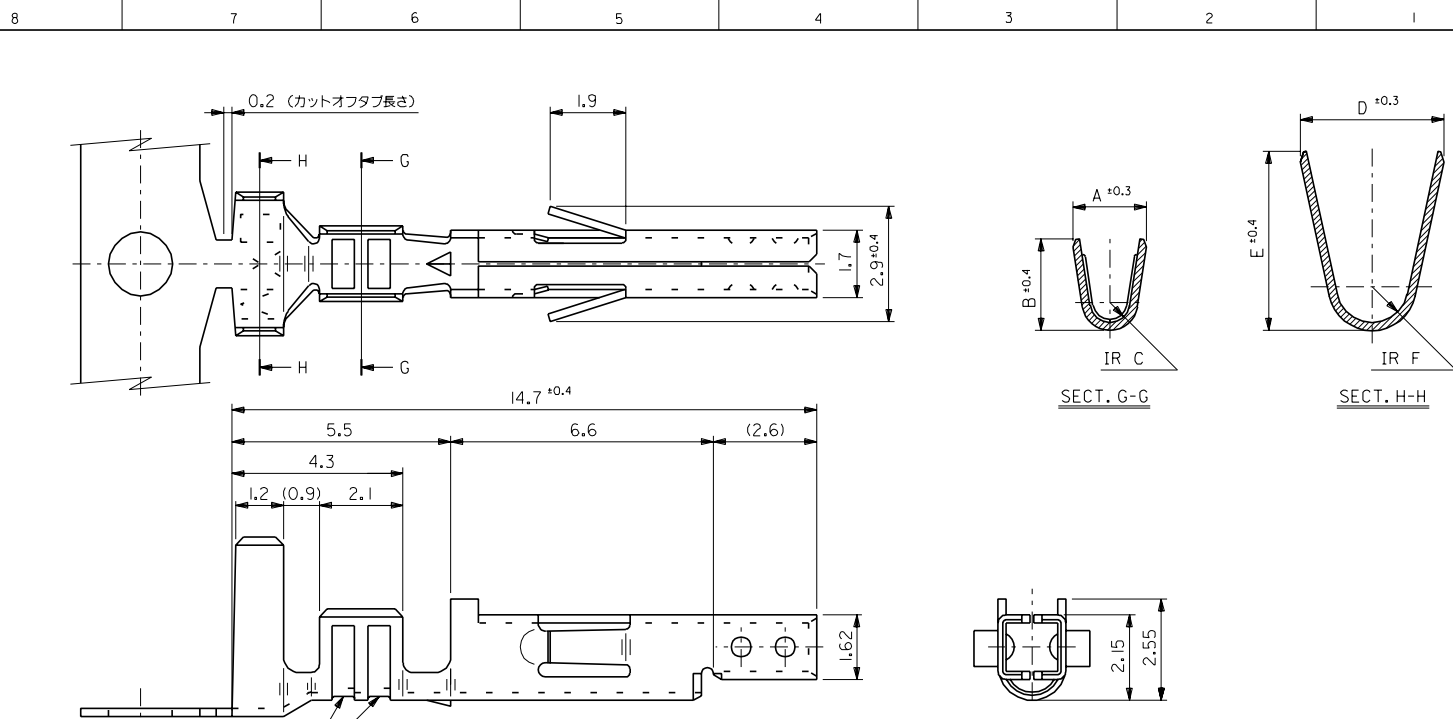

錫メッキ済リン青銅 (板厚: 0.203)	0.9	4.5	3.6	0.5	2.3	1.9	∅ 1.3-3.1	# 18-24	39-00-0060	5556 PBT	バラ状
									-0059	PBT	連鎖状
錫メッキ済黄銅 (板厚: 0.203)	0.6	2.3	2.3	0.4	1.65	1.8	∅ 0.9-1.8	# 22-28	-0047	T2L	バラ状
									-0046	T2	連鎖状
	0.9	4.5	3.6	0.5	2.3	1.9	∅ 1.3-3.1	# 18-24	-0039	TL	バラ状
材料	F	E	D	C	B	A	被覆外径	適用電線	EDP NO.	ENG. NO.	端子形状

注記  
 1. 適合ハウジング: 5557 シリーズ  
 2. 嵌合相手 : 5558, 5566, 5569 シリーズ  
 △ 適用電線が # 22-28 の製品のセレーション数は 1 とする。

材料 MATERIAL		表参照		MOLEX JAPAN CO., LTD. 日本モレックス株式会社	
仕上げ FINISH		—		EDP NO. 39-00-00**	
適用電線範囲 WIRE RANGE		表参照		ENG. NO. SD-5556****	
被覆外径 INS. RANGE		表参照		REV G	
角度 ANGLE	±3°	F 変更	WC90279	Y.K. S.K.	98/11/6
30 以上 OVER	±0.3	E 変更	WC90012	Y.K. S.K.	98/7/6
10 以上 未過 UNDER	±0.25	D 変更&再作図 (J10380)	H.H.	Y.K. S.K.	98/5/6
10 未過 UNDER	±0.2	記号 LTR	変更内容 REVISION RECORD	DR. CHK.	日付 DATE
一般公差 GENERAL TOLERANCES		REVISE ONLY ON CAD SYSTEM			

THIS DRAWING CONTAINS INFORMATION THAT IS PROPRIETARY TO MOLEX JAPAN AND SHOULD NOT BE USED WITHOUT WRITTEN PERMISSION  
 本図面は日本モレックス (株) の所有する情報を含むもので 当社の許可なく複製を禁止する。 MXJ-8

EDP NO. SHEET 1 OF 2  
 SD-5556\*\*\*\*  
 ENG. NO. SEE SHEET 2 OF 2  
 DIMENSIONS IN METRIC DO NOT SCALE DRAWING

NOTES

1. APPLICABLE HOUSING : 5557 SERIES.
  2. MATES WITH TERMINAL : 5558, 5566, 5569 SERIES.
  3. (METRIC) VALUES SHOWN GOVERN OVER ENGLISH CONVERSION VALUES.
  4. GENERAL TOLERANCES OF ENGLISH CONVERSION VALUES : ±.008 INCH.
- △ THE NUMBER OF SERRATIONS TO BE ONE FOR WIRE RANGE #22-28.

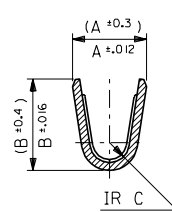
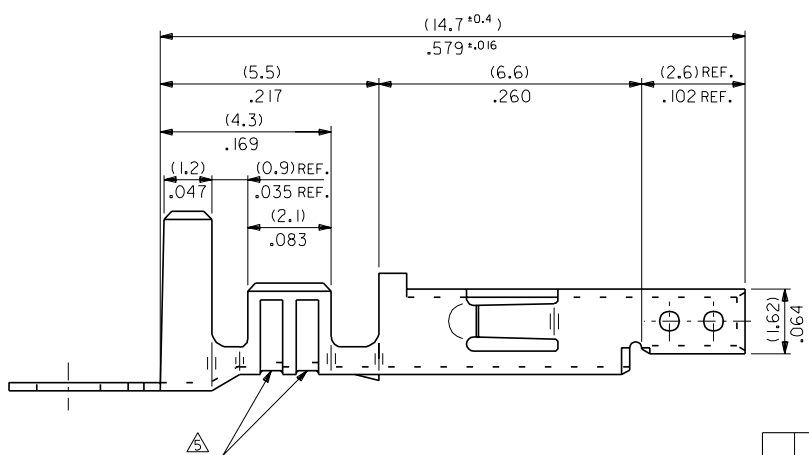
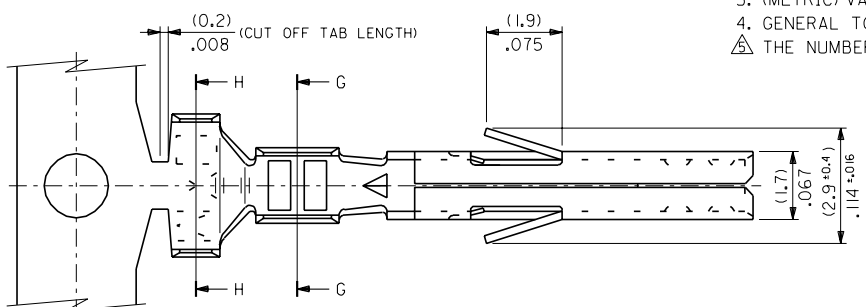

SECT. G-G

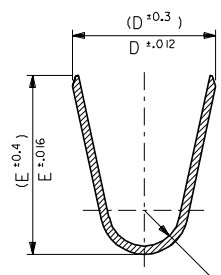

SECT. H-H

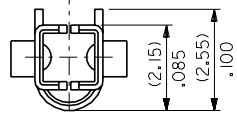

		材料 MATERIAL		SEE SHEET 2 OF 2	MOLEX-JAPAN CO.,LTD. 日本モレックス株式会社	
		仕上げ FINISH		SEE SHEET 2 OF 2	EDP NO. SEE SHEET 2 OF 2	
角度 ANGLE		±30	H	REVISED (JC90279) Y.K. S.K. 98/11/6	適用電線範囲 WIRE RANGE SEE SHEET 2 OF 2	
30以上 OVER		±0.3	G	REVISED (JC90012) Y.K. S.K. 98/7/6	被覆外径 INS. RANGE SEE SHEET 2 OF 2	
10以上 未過 OVER 30 UNDER		±0.25	F	REVISED & REDRAWN (JC80619) Y.K. S.K. 98/5/6	DRAWN BY 9/5/8 CHK'D BY 9/11/8 H.HIRAMOTO K.T.S.KUNISHI	
10 UNDER		±0.2	記号 LTR	変更内容 REVISION RECORD DR. CHK. DATE	APPR'D BY 9/11/8 尺度 SCALE 10 - 1 M.FUKUSHIMA	
一般公差 GENERAL TOLERANCES		REVISE ONLY ON CAD SYSTEM			TITLE 名称 NEW MINI. FIT CONN. CRIMP RECEPTACLE	

THIS DRAWING CONTAINS INFORMATION THAT IS PROPRIETARY TO MOLEX/JAPAN AND SHOULD NOT BE USED WITHOUT WRITTEN PERMISSION  
 本図面は日本モレックス(株)の所有する情報を含むもので 当社の許可なく複製を禁止する。

MXJ-8

8 7 6 5 4 3 2 1

	(0.9)	(4.5)	(3.6)	(0.6)	(2.7)	(2.3)	(3.1)	#16	39-00-0119	5556 PBS3L	LOOSE	
TIN OVER NICKEL PLATED PHOSPHOR BRONZE	.035	.177	.142	.024	.106	.091	∅ .122 MAX.		↑ -0118	↑ PBS3	CHAIN	
	(0.6)	(2.3)	(2.3)	(0.4)	(1.65)	(1.8)	∅ (0.9-1.8)	#22-28	-0117	PBS2L	LOOSE	
	.024	.091	.091	.016	.065	.071	∅ .035-.071		-0116	PBS2	CHAIN	
TIN PLATED PHOSPHOR BRONZE	(0.9)	(4.5)	(3.6)	(0.5)	(2.3)	(1.9)	∅ (1.3-3.1)	#18-24	-0115	PBSL	LOOSE	
	.035	.177	.142	.020	.091	.075	∅ .051-.122		-0114	PBS	CHAIN	
	(0.9)	(4.5)	(3.6)	(0.6)	(2.7)	(2.3)	∅ (3.1) MAX.	#16	-0080	PBT3L	LOOSE	
TIN OVER NICKEL PLATED BRASS	.035	.177	.142	.024	.106	.091	∅ .122 MAX.	#16	-0079	PBT3	CHAIN	
	(0.6)	(2.3)	(2.3)	(0.4)	(1.65)	(1.8)	∅ (0.9-1.8)	#22-28	-0066	PBT2L	LOOSE	
	.024	.091	.091	.016	.065	.071	∅ .035-.071		-0065	PBT2	CHAIN	
TIN OVER COPPER PLATED BRASS	(0.9)	(4.5)	(3.6)	(0.5)	(2.3)	(1.9)	∅ (1.3-3.1)	#18-24	-0060	PBTL	LOOSE	
	.035	.177	.142	.020	.091	.075	∅ .051-.122		-0059	PBT	CHAIN	
	(0.9)	(4.5)	(3.6)	(0.6)	(2.7)	(2.3)	∅ (3.1) MAX.	#16	-0113	S3L	LOOSE	
MATERIAL	.035	.177	.142	.024	.106	.091	∅ .122 MAX.	#16	-0112	S3	CHAIN	
	(0.6)	(2.3)	(2.3)	(0.4)	(1.65)	(1.8)	∅ (0.9-1.8)	#22-28	-0111	S2L	LOOSE	
	.024	.091	.091	.016	.065	.071	∅ .035-.071		-0110	S2	CHAIN	
MATERIAL	(0.9)	(4.5)	(3.6)	(0.5)	(2.3)	(1.9)	∅ (1.3-3.1)	#18-24	-0109	SL	LOOSE	
	.035	.177	.142	.020	.091	.075	∅ .051-.122		-0108	S	CHAIN	
	(0.9)	(4.5)	(3.6)	(0.6)	(2.7)	(2.3)	∅ (3.1) MAX.	#16	-0078	T3L	LOOSE	
MATERIAL	.035	.177	.142	.024	.106	.091	∅ .122 MAX.	#16	-0077	T3	CHAIN	
	(0.6)	(2.3)	(2.3)	(0.4)	(1.65)	(1.8)	∅ (0.9-1.8)	#22-28	-0047	T2L	LOOSE	
	.024	.091	.091	.016	.065	.071	∅ .035-.071		-0046	T2	CHAIN	
MATERIAL	(0.9)	(4.5)	(3.6)	(0.5)	(2.3)	(1.9)	∅ (1.3-3.1)	#18-24	↓ -0039	↓ TL	LOOSE	
	.035	.177	.142	.020	.091	.075	∅ .051-.122		39-00-0038	5556 T	CHAIN	
	MATERIAL		F	E	D	C	B	A	INS. RANGE	WIRE RANGE	EDP NO.	ENG. NO.

材料 MATERIAL		SEE CHART	moLEX MOLEX-JAPAN CO.,LTD. 日本モレックス株式会社
THICKNESS : (0.203)/.008		SEE CHART	
仕上げ FINISH		SEE CHART	EDP. NO.
適用電線範囲 WIRE RANGE		SEE CHART	SEE CHART
被覆外径 INS. RANGE		SEE CHART	ENG. NO. SHEET 2 OF 2 REV
DRAWN BY 9/5/08 H.HIRAMOTO		CHK'D BY 9/11/09 K.T.S.KUNISHI	SD-5556**** J
APPRO'D BY 9/11/09 M.FUKUSHIMA		尺度 SCALE 10 - 1	TITLE 名称 NEW MINI, FIT CONN. CRIMP RECEPTACLE

角度 ANGLE	±3°	H	SEE SHEET 1 OF 2	Y.K.S.K.	9/11/06
30°以上 OVER	±0.3	G	SEE SHEET 1 OF 2	Y.K.S.K.	9/17/06
10°以上 未過 UNDER 30°	±0.25	F	SEE SHEET 1 OF 2	Y.K.S.K.	9/15/06
未過 UNDER 10°	±0.2	記号 LTR	変更内容 REVISION RECORD	DR. CHK.	日付 DATE
一般公差 GENERAL TOLERANCES					

REVISE ONLY ON CAD SYSTEM  
THIS DRAWING CONTAINS INFORMATION THAT IS PROPRIETARY TO MOLEX/JAPAN AND SHOULD NOT BE USED WITHOUT WRITTEN PERMISSION  
本図面は日本モレックス(株)の所有する情報を含むもので 当社の許可なく複製を禁止する。 MXJ-8