

# 4.2 mm PE Series Connector System

(Wire-to-Wire, Wire-to-Board and Wire-to-Panel)

## DESCRIPTION

- Low cost, wire-to-wire, wire-to-board and wire-to-panel connectors with 4.2 mm centerline

## APPLICATIONS

- Computer motherboards/power supplies
- Harness assemblies used in the Vending, Gaming and Appliance industries
- Car alarm systems
- Heating systems

## KEY FEATURES

- Easy mate and unmate with positive latch design
- Single-row, 3-5 positions: receptacles, panel mount or free-hanging plugs
- Double-row, 2-24 positions (even only): receptacles, panel mount or free-hanging plugs, and vertical or right-angle pin headers
- Available in UL 94V-2 or UL 94V-0 flammability rated nylon
- Products are lead free to help promote a cleaner environment
- Intermateable and interchangeable with Molex Mini-Fit, Jr. and intermateable AMP-DUAC connectors

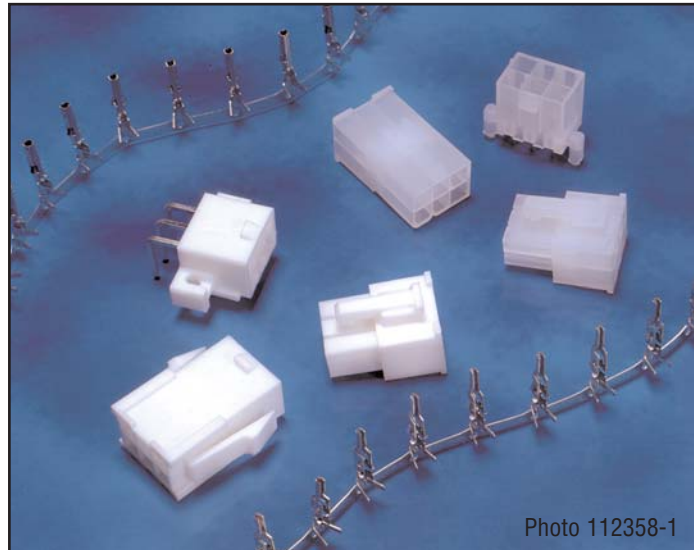

Photo 112358-1

Revised 06/04 1309245

## ELECTRICAL

- Voltage: 600 VAC
- Current: 9 amps max. in 2-position applications
- Dielectric Withstanding Voltage: 1500 VAC min.
- Insulation Resistance: 1000 megohms min.

## MECHANICAL

- Connector Mating: 1.55 lb. [6.90 N] max. per circuit
- Connector Unmating: .11 lb. [.49 N] min. per circuit
- Contact Retention: 4.88 lb. [21.71 N] min. per contact
- Durability: 50 cycles, mating and unmating

## MATERIALS

- Housings: Nylon, UL 94V-2 and UL 94V-0
- Contacts: Brass or Phos. Bronze with tin plating (Lead-Free) or gold plating

## STANDARDS & SPECS

- Component Recognized by UL and Certified by CSA
- UL File No. E28476 and CSA File No. 208567
- Tyco Electronics Design For Environment (DFE) Standard 230-5

## FOR MORE INFORMATION

### Technical Support

Phone: 1-800-522-6752

Internet: [www.tycoelectronics.com](http://www.tycoelectronics.com)

E-mail:

[newproducts@tycoelectronics.com](mailto:newproducts@tycoelectronics.com)

USA: 1-800-522-6752

Canada: 1-905-470-4425

Mexico: 01-800-733-8926

C. America: 52-55-5-792-0425

South America: 55-11-3611-1514

Hong Kong: 852-2735-1628

Japan: 81-44-844-8013

UK: 44-141-810-8967

new product

# 4.2 mm PE Series Connector System

(Wire-to-Wire, Wire-to-Board and Wire-to-Panel)

## HOUSINGS □ PRODUCT OFFERING & DIMENSIONS

### SINGLE ROW

| No. of Positions | UL 94V-2 Housings |                   |                    | UL 94V-0 Housings |                   |                    |
|------------------|-------------------|-------------------|--------------------|-------------------|-------------------|--------------------|
|                  | Panel Mount Plug  | Free-Hanging Plug | Receptacle Housing | Panel Mount Plug  | Free-Hanging Plug | Receptacle Housing |
| 3*               | 1586101-3         | 1586103-3         | 1586105-3          | 1586102-3         | 1586104-3         | 1586106-3          |
| 4                | 1586022-4         | 1586024-4         | 1586026-4          | 1586023-4         | 1586025-4         | 1586027-4          |
| 5                | 1586022-5         | 1586024-5         | 1586026-5          | 1586023-5         | 1586025-5         | 1586027-5          |

\*Note: 3 position housings are First Mate/Last Break.

Panel Mount Plug Housing

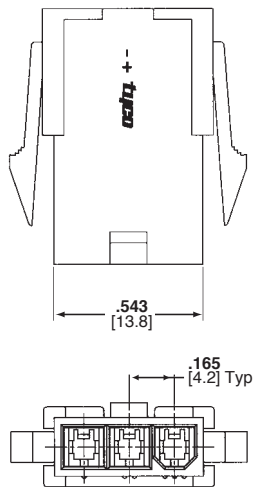

Receptacle Housing

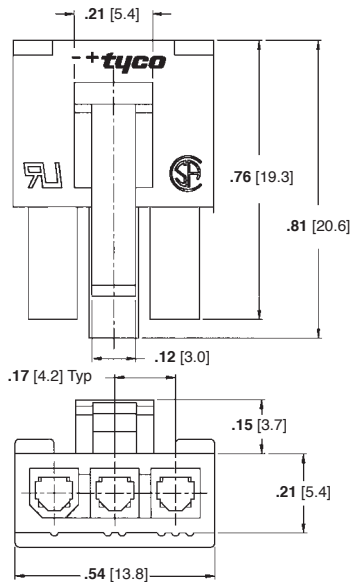

Free-Hanging Plug Housing

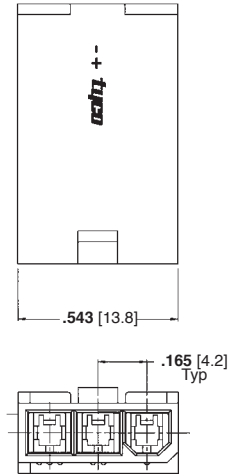

### DOUBLE ROW

| No. of Positions | UL 94V-2 Housings |                   |                    | UL 94V-0 Housings |                   |                    |
|------------------|-------------------|-------------------|--------------------|-------------------|-------------------|--------------------|
|                  | Panel Mount Plug  | Free-Hanging Plug | Receptacle Housing | Panel Mount Plug  | Free-Hanging Plug | Receptacle Housing |
| 2                | 794953-2          | 1586000-2         | 794954-2           | 1586018-2         | 1586017-2         | 1586019-2          |
| 4                | 794953-4          | 1586000-4         | 794954-4           | 1586018-4         | 1586017-4         | 1586019-4          |
| 6                | 794953-6          | 1586000-6         | 794954-6           | 1586018-6         | 1586017-6         | 1586019-6          |
| 8                | 794953-8          | 1586000-8         | 794954-8           | 1586018-8         | 1586017-8         | 1586019-8          |
| 10               | 1-794953-0        | 1-1586000-0       | 1-794954-0         | 1-1586018-0       | 1-1586017-0       | 1-1586019-0        |
| 12               | 1-794953-2        | 1-1586000-2       | 1-794954-2         | 1-1586018-2       | 1-1586017-2       | 1-1586019-2        |
| 14               | 1-794953-4        | 1-1586000-4       | 1-794954-4         | 1-1586018-4       | 1-1586017-4       | 1-1586019-4        |
| 16               | 1-794953-6        | 1-1586000-6       | 1-794954-6         | 1-1586018-6       | 1-1586017-6       | 1-1586019-6        |
| 18               | 1-794953-8        | 1-1586000-8       | 1-794954-8         | 1-1586018-8       | 1-1586017-8       | 1-1586019-8        |
| 20               | 2-794953-0        | 2-1586000-0       | 2-794954-0         | 2-1586018-0       | 2-1586017-0       | 2-1586019-0        |
| 22               | 2-794953-2        | 2-1586000-2       | 2-794954-2         | 2-1586018-2       | 2-1586017-2       | 2-1586019-2        |
| 24               | 2-794953-4        | 2-1586000-4       | 2-794954-4         | 2-1586018-4       | 2-1586017-4       | 2-1586019-4        |

Note: Plug housings accept pin contacts and receptacle housings accept socket contacts on page 4.

Panel Mount Plug Housing

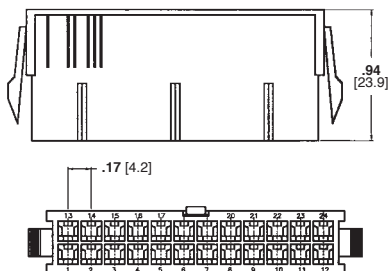

Receptacle Housing

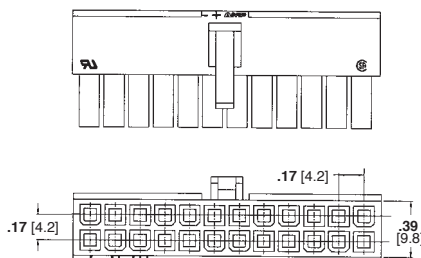

Free-Hanging Plug Housing

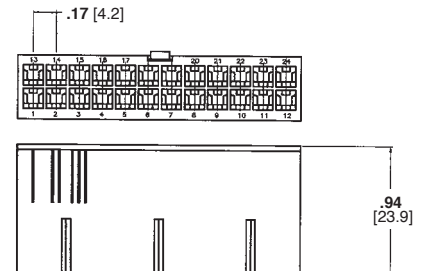

# 4.2 mm PE Series Connector System

(Wire-to-Wire, Wire-to-Board and Wire-to-Panel)

## PIN HEADERS □ PRODUCT OFFERING

| No. of Positions | UL 94V-2 Pin Headers |             |             |             | UL 94V-0 Pin Headers |             |             |             |
|------------------|----------------------|-------------|-------------|-------------|----------------------|-------------|-------------|-------------|
|                  | Vertical             |             | Right-Angle |             | Vertical             |             | Right-Angle |             |
|                  | w/o Pegs             | w/Pegs      | w/o Pegs    | Screw Mount | w/o Pegs             | w/Pegs      | w/o Pegs    | Screw Mount |
| 2                | 1586037-2            | 1586039-2   | 1586041-2   | 1586043-2   | 1586038-2            | 1586040-2   | 1586042-2   | 1586044-2   |
| 4                | 1586037-4            | 1586039-4   | 1586041-4   | 1586043-4   | 1586038-4            | 1586040-4   | 1586042-4   | 1586044-4   |
| 6                | 1586037-6            | 1586039-6   | 1586041-6   | 1586043-6   | 1586038-6            | 1586040-6   | 1586042-6   | 1586044-6   |
| 8                | 1586037-8            | 1586039-8   | 1586041-8   | 1586043-8   | 1586038-8            | 1586040-8   | 1586042-8   | 1586044-8   |
| 10               | 1-1586037-0          | 1-1586039-0 | 1-1586041-0 | 1-1586043-0 | 1-1586038-0          | 1-1586040-0 | 1-1586042-0 | 1-1586044-0 |
| 12               | 1-1586037-2          | 1-1586039-2 | 1-1586041-2 | 1-1586043-2 | 1-1586038-2          | 1-1586040-2 | 1-1586042-2 | 1-1586044-2 |
| 14               | 1-1586037-4          | 1-1586039-4 | 1-1586041-4 | 1-1586043-4 | 1-1586038-4          | 1-1586040-4 | 1-1586042-4 | 1-1586044-4 |
| 16               | 1-1586037-6          | 1-1586039-6 | 1-1586041-6 | 1-1586043-6 | 1-1586038-6          | 1-1586040-6 | 1-1586042-6 | 1-1586044-6 |
| 18               | 1-1586037-8          | 1-1586039-8 | 1-1586041-8 | 1-1586043-8 | 1-1586038-8          | 1-1586040-8 | 1-1586042-8 | 1-1586044-8 |
| 20               | 2-1586037-0          | 2-1586039-0 | 2-1586041-0 | 2-1586043-0 | 2-1586038-0          | 2-1586040-0 | 2-1586042-0 | 2-1586044-0 |
| 22               | 2-1586037-2          | 2-1586039-2 | 2-1586041-2 | 2-1586043-2 | 2-1586038-2          | 2-1586040-2 | 2-1586042-2 | 2-1586044-2 |
| 24               | 2-1586037-4          | 2-1586039-4 | 2-1586041-4 | 2-1586043-4 | 2-1586038-4          | 2-1586040-4 | 2-1586042-4 | 2-1586044-4 |

**Note:** All Headers have Brass, Tin-Plated contacts.

## PRODUCT DIMENSIONS

### Vertical Pin Headers (Part No. 1586037 shown w/o pegs)

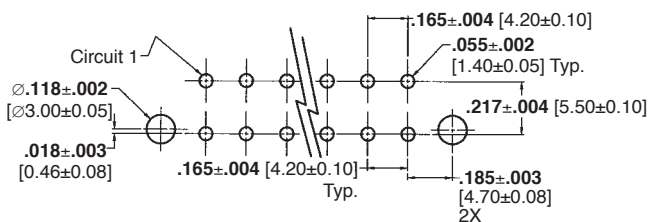
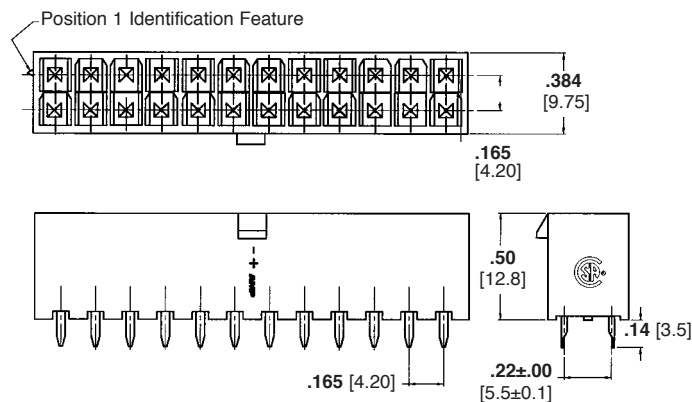

PCB Layout: Component Side (shown with pegs)  
Recommended Board Thickness .070 [1.78]

### Right-Angle Pin Headers (Part No. 1586043 Screw Mount)

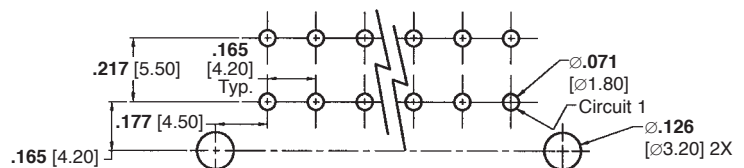
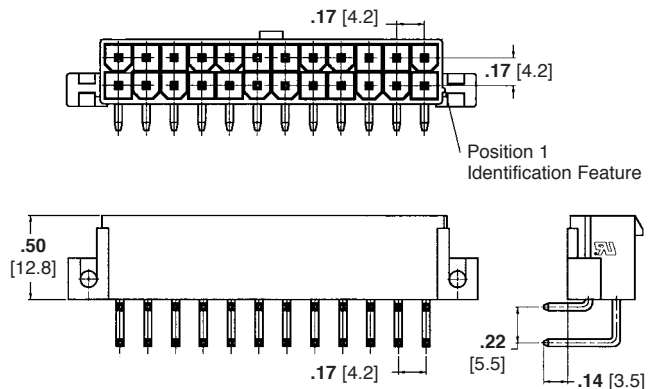

PCB Layout: Component Side (screw mount shown)  
Recommended Board Thickness .063 [1.60]

# 4.2 mm PE Series Connector System

(Wire-to-Wire, Wire-to-Board and Wire-to-Panel)

## CONTACTS □ PRODUCT OFFERING

| Wire Range<br>(AWG) | Material &<br>Finish | Pin        |            | Socket     |            | Applicator<br>Part Number <sup>1</sup> | Hand Tool<br>Part Number |
|---------------------|----------------------|------------|------------|------------|------------|--|--------------------------|
|                     |                      | Strip Form | Loose Form | Strip Form | Loose Form |  |                          |
| 26-22               | Brass, Pre-Tin       | 794957-1   | 1586316-1  | 794958-1   | 1586317-1  | 1385448-X                              | 91387-1                  |
|                     | Phos. Brz., Pre-Tin  | 794957-3   | 1586316-3  | 794958-3   | 1586317-3  |  |                          |
|                     | Brass, Gold          | 794957-2   | 1586316-2  | 794958-2   | 1586317-2  |  |                          |
|                     | Phos. Brz., Gold     | 794957-4   | 1586316-4  | 794958-4   | 1586317-4  |  |                          |
| 22-18               | Brass, Pre-Tin       | 794955-1   | 1586314-1  | 794956-1   | 1586315-1  | 680557-X                               | 91388-1                  |
|                     | Phos. Brz., Pre-Tin  | 794955-3   | 1586314-3  | 794956-3   | 1586315-3  |  |                          |
|                     | Brass, Gold          | 794955-2   | 1586314-2  | 794956-2   | 1586315-2  |  |                          |
|                     | Phos. Brz., Gold     | 794955-4   | 1586314-4  | 794956-4   | 1586315-4  |  |                          |

Extraction Tool Part Number 1586343-1

<sup>1</sup> For applicator and machine part numbers, contact Technical Support.

**SOCKET**  
(used in Receptacle Housing)

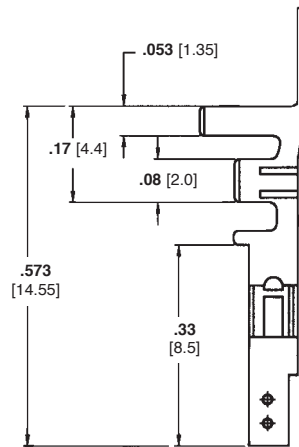

**PIN**  
(used in Plug Housing)

