

**REMARKS**  
 Bemerkungen

- 1 CONTACT BODY PRE SILVER PLATED MIN. 0.8µm CONTACT ZONE SELECTIVE PRE SILVER PLATED MIN. 3µm  
 Kontaktkörper vorversilbert min. 0.8µm Kontaktzone selektiv vorversilbert min. 3µm
- 2 CONTACT ZONE GOLD PLATED MIN. 0.8µm OVER MIN. 1.3µm NI-LAYER CRIMP AREA MIN. 1µm TIN PLATED OVER NI-LAYER  
 Kontaktzone vergoldet min. 0.8µm über min. 1.3µm Ni-Zwischenschicht Crimpbereich min. 1µm verzinkt über Ni-Zwischenschicht
- 3 CANTILEVER SPRING INSIDE AND OUTSIDE 0.4-1.2µm Au  
 Oberfeder innen und außen 0.4-1.2µm Au
- 4 CONTACT BODY, CONTACT SPRING INSIDE AND CRIMP AREA MIN. 1µm TIN PLATED OVER NI-LAYER, TOUCHING AREA TO CANTILEVER SPRING AND CONTACT SPRING OUTSIDE SELECTIVE 0.8µm Au OVER MIN. 1.3µm NI-LAYER  
 Kontaktkörper, Kontaktfeder innen und Crimpbereich min. 1µm verzinkt über Ni-Zwischenschicht, Anlagefläche zur Oberfeder und Kontaktfeder aussen selektiv 0.8µm vergoldet über min. 1.3µm Ni-Zwischenschicht
- 5 CONTACT ZONE AND TOUCHING AREA TO CANTILEVER SPRING MIN. 0.8µm SELECTIVE Au PLATED OVER 1.3µm Ni PLATED, CRIMP AREA MIN. 1µm TIN PLATED OVER NI-LAYER  
 Kontaktzone und Anlagefläche zur Oberfeder min. 0.8µm vergoldet über min. 1.3µm Ni-Zwischenschicht, Crimpbereich min. 1µm verzinkt über Ni-Zwischenschicht
- 6 CONTACT BODY AND CRIMP AREA MIN. 1µm TIN PLATED OVER NI-LAYER, TOUCHING AREA TO CANTILEVER SPRING SELECTIVE 0.8µm Au OVER MIN. 1.3µm Ni-LAYER  
 Kontaktkörper und Crimpbereich min. 1µm verzinkt über Ni-Zwischenschicht, Anlagefläche zur Oberfeder selektiv 0.8µm vergoldet über min. 1.3µm Ni-Zwischenschicht
- 7 CUT OFF OPTIONAL  
 Abschnitt/Freisschnitt optional

REV. NO.	DESCRIPTION	DATE	BY	APP.
A1	REVISIONS			

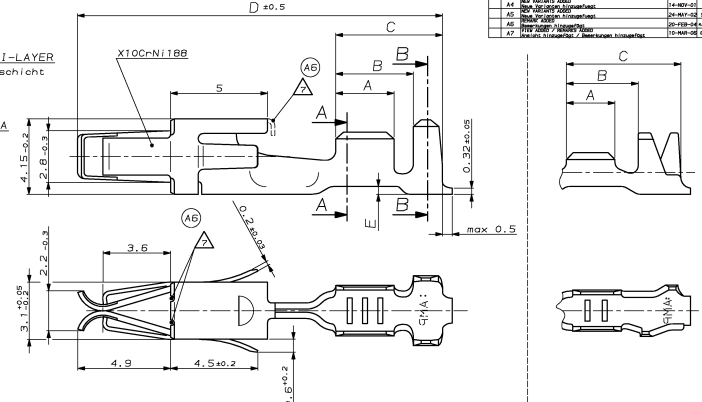

AMP ORDER-NO. STRIP FORM Bestellnr.	AMP ORDER-NO. LOOSE PIECE Bestellnr.	MATERIAL Markstoff	SURFACE Oberfläche	DGB (mm²)	SECTION A-A Schnitt A-A	SECTION B-B Schnitt B-B	WIRE CRIMP Drahtform	SECTION A-A Schnitt A-A	SECTION B-B Schnitt B-B	APPLICATION TOOL Anlegewerkz.	HAND TOOL Handzange	CRIMP DIMENSION (mm)				
												A	B	C	D	E
2-927773-1	2-927781-1	CuSn4	FLK	>1.0-2.5	E = 3.6 G = 3.8 Dw = 1.8	H = 5.5 K = 5.8 D = 3.6	1.25mm² = 1.44 1.5mm² = 1.51 2.0mm² = 1.64 2.5mm² = 1.77	E = 2.8 G = 3.9 Dw = 1.7	H = 4.2 K = 5.2 r = 2.4	MGC-Applicator 878190-2	S39635-1 #11 MGC-APL S39674-2	3	3	4	3	0.4
927773-6	927781-6	CuSn4	vorverzinkt min 1µm	>1.0-2.5	E = 3.6 G = 3.8 Dw = 1.8	H = 4.7 K = 4.9 D = 2.6	1.25mm² = 1.44 1.5mm² = 1.51 2.0mm² = 1.64 2.5mm² = 1.77	E = 2.8 G = 3.9 Dw = 1.7	H = 3.8 K = 4.3 R = 2.3	MGC-Applicator 878190-2	S39635-1 #11 MGC-APL S39674-2	3	3	4	3	0.4
927773-3	927781-3	CuFe2	vorverzinkt min 1µm	0.5-1.0	E = 2.6 G = 2.8 Dw = 1.1	H = 3.6 K = 3.9 D = 1.8	0.5mm² = 1.18 0.75mm² = 1.27 1.0mm² = 1.36	E = 2.2 G = 2.8 Dw = 1.2	H = 2.8 K = 3.4 R = 1.6	MGC-Applicator 878181-2	S39635-1 #11 MGC-APL S39674-2	3	4	5	18.8	0.4
927774-1	927776-1	CuSn4	FLR	0.2-0.5	E = 2.1 G = 2.1 Dw = 0.8	H = 2.7 K = 2.8 D = 1.4	0.2mm² = 0.98 0.25mm² = 1.00 0.35mm² = 1.05 0.5mm² = 1.12	E = 1.7 G = 2.1 Dw = 0.8	H = 2.2 K = 2.4 R = 1.3	MGC-Applicator 878332-2	S39635-1 #11 MGC-APL S39737-2	2.5	3.5	5.6	18.8	0.4
2-963708-1	2-963777-1	CuSn4	FLR	0.08-0.2	E = 1.7 G = 1.7 Dw = 0.6	H = 3.1 K = 3.2 D = 1.6	0.08mm² = 0.79 0.14mm² = 0.83 0.22mm² = 0.87	E = 1.5 G = 1.8 Dw = 0.6	H = 2.5 K = 2.8 R = 1.4	MGC-Applicator 878599-2	734414-1	2.5	3.7	5.9	18.8	0.4

0.5-2.5mm²      0.08-0.5mm²

**UNSEALED**  
 ungedichtet

THIS DRAWING IS NOT SUBJECT TO CONSTANT CHANGING SERVICE AND DOES NOT LAY CLAIM TO BE COMPLETE. FOR DEFINITE SPECIFICATION SEE RESPECTIVE AMP CUSTOMER DRAWINGS. FURTHER VERSIONS ON INQUIRY.

Diese Zeichnung unterliegt nicht dem ständigen Änderungsdienst und erhebt keinen Anspruch auf Vollständigkeit. Verbindliche Angaben sind der jeweiligen AMP-Kundenzeichnung zu entnehmen. Weitere Ausführungen auf Anfrage.

AMP ORDER-NO. STRIP FORM Bestellnr. AMP ORDER-NO. LOOSE PIECE Bestellnr.	MATERIAL Markstoff SURFACE Oberfläche DGB (mm²)	SECTION A-A Schnitt A-A SECTION B-B Schnitt B-B WIRE CRIMP Drahtform SECTION A-A Schnitt A-A SECTION B-B Schnitt B-B	APPLICATION TOOL Anlegewerkz. HAND TOOL Handzange EXTRACTION TOOL Ausd-Druckwerkzeug No. 1: 568107-1	PRODUCT GROUP DRAWING FOR JUNIOR POWER THIN CONTACT Produkt-Gruppen-Zeichnung fuer: JPT Kontakt THE DATE FOR THIS DRAWING: 1998-11-10 A1 00779 (REPLACES 11E-1801E-002) CUSTOMER DRAWING: ZKUNDEZEICHNUNG
---	--	---	--	---

- REMARKS**  
 Bemerkungen
- CONTACT BODY PRE SILVER PLATED MIN. 0.8µm CONTACT ZONE SELECTIVE PRE SILVER PLATED MIN. 3µm  
 Kontaktkörper vorversilbert min. 0.8µm Kontaktzone selektiv vorversilbert min. 3µm
  - CONTACT ZONE GOLD PLATED MIN. 0.8µm OVER MIN. 1.3µm NI-LAYER CRIMP AREA MIN. 1µm TIN PLATED OVER NI-LAYER  
 Kontaktzone vergoldet min. 0.8µm über min. 1.3µm Ni-Zwischenschicht Crimpbereich min. 1µm verzinkt über Ni-Zwischenschicht
  - CANTILEVER SPRING INSIDE AND OUTSIDE 0.4-1.2µm Au  
 Oberfeder innen und außen 0.4-1.2µm Au
  - CONTACT BODY, CONTACT SPRING INSIDE AND CRIMP AREA MIN. 1µm TIN PLATED OVER NI-LAYER, TOUCHING AREA TO CANTILEVER SPRING AND CONTACT SPRING OUTSIDE SELECTIVE 0.8µm Au OVER MIN. 1.3µm NI-LAYER  
 Kontaktkörper, Kontaktfeder innen und Crimpbereich min. 1µm verzinkt über Ni-Zwischenschicht, Anlagefläche zur Oberfeder und Kontaktfeder aussen selektiv 0.8µm vergoldet über min. 1.3µm Ni-Zwischenschicht
  - CONTACT ZONE AND TOUCHING AREA TO CANTILEVER SPRING MIN. 0.8µm SELECTIVE Au PLATED OVER 1.3µm Ni PLATED, CRIMP AREA MIN. 1µm TIN PLATED OVER NI-LAYER  
 Kontaktzone und Anlagefläche zur Oberfeder min. 0.8µm vergoldet über min. 1.3µm Ni-Zwischenschicht Crimpbereich min. 1µm verzinkt über Ni-Zwischenschicht
  - CONTACT BODY AND CRIMP AREA MIN. 1µm TIN PLATED OVER NI-LAYER, TOUCHING AREA TO CANTILEVER SPRING SELECTIVE 0.8µm Au OVER MIN. 1.3µm NI-LAYER  
 Kontaktkörper und Crimpbereich min. 1µm verzinkt über Ni-Zwischenschicht, Anlagefläche zur Oberfeder selektiv 0.8µm vergoldet über min. 1.3µm Ni-Zwischenschicht
  - CUT OFF OPTIONAL  
 Abschnitt/Freischnitt optional

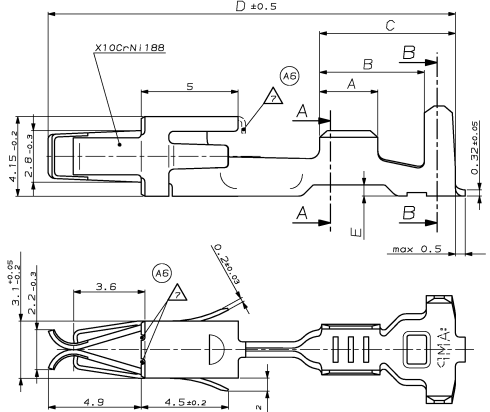

**SINGLE WIRE SEAL**  
 Einzel-Dichtungs-System

AMP ORDER-No.	AMP ORDER-No.	MATERIAL	SURFACE	DGB	WIRE CRIMP	WIRE CRIMP	WIRE CRIMP	WIRE CRIMP	AMP ORDER-No.	AMP ORDER-No.	CRIMP DIMENSION (mm)							
											A	B	C	D	E			
2-927766-1	E 2-929929-1	CuSn4	FLK	>1.0-2.5	E = 3.6 G = 3.8 D <sub>w</sub> = 1.8	H = 5.4 K = 4.6 D = 3.2	2.5mm <sup>2</sup> = 1.77 2.0mm <sup>2</sup> = 1.64 1.5mm <sup>2</sup> = 1.51	E = 2.8 G = 3.9 D <sub>w</sub> = 1.7	H = 4.8 K = 4.2 R = 2.8	MOC-Application 2-878845-2	539635-1 416 Material 539797-2	3.5	5.9	7.5	18.8	0.4	828905-1	828922-1
1-927766-1	E 1-929929-1	CuFe2	FLR	>1.0-2.5	E = 3.6 G = 3.8 D <sub>w</sub> = 1.8	H = 5.4 K = 4.6 D = 3.2	2.5mm <sup>2</sup> = 1.77 2.0mm <sup>2</sup> = 1.64 1.5mm <sup>2</sup> = 1.51	E = 2.8 G = 3.9 D <sub>w</sub> = 1.7	H = 4.8 K = 4.2 R = 2.8	MOC-Application 2-878845-2	539635-1 416 Material 539797-2	3.5	5.9	7.5	21	0.4	828905-1	828922-1
2-929937-1	D 2-929936-1	CuSn4	FLR	0.5-1.0	E = 2.6 G = 2.8 D <sub>w</sub> = 1.1	H = 5.4 K = 4.6 D = 3.2	1.0mm <sup>2</sup> = 1.36 0.75mm <sup>2</sup> = 1.27 0.5mm <sup>2</sup> = 1.18	E = 2.2 G = 2.8 D <sub>w</sub> = 1.2	H = #4.6 K = 4.2 R = 2.3	MOC-Application 878335-2	539635-1 416 Material 539797-2	3	5.4	7	21	0.6	828904-1	828922-1
2-929937-3	C 2-929936-3	CuSn4	FLR	0.5-1.0	E = 2.6 G = 2.8 D <sub>w</sub> = 1.1	H = 5.4 K = 4.6 D = 3.2	1.0mm <sup>2</sup> = 1.36 0.75mm <sup>2</sup> = 1.27 0.5mm <sup>2</sup> = 1.18	E = 2.2 G = 2.8 D <sub>w</sub> = 1.2	H = #4.6 K = 4.2 R = 2.3	MOC-Application 878335-2	539635-1 416 Material 539797-2	3	5.4	7	18.8	0.6	828904-1	828922-1
2-929941-1	D 2-929940-1	CuSn4	FLR	0.2-0.5	E = 2.1 G = 2.1 D <sub>w</sub> = 0.8	H = 5.4 K = 4.6 D = 3.2	0.5mm <sup>2</sup> = 1.12 0.35mm <sup>2</sup> = 1.05 0.25mm <sup>2</sup> = 1.0 0.2mm <sup>2</sup> = 0.98	E = 1.7 G = 2.1 D <sub>w</sub> = 0.8	H = 4.2 K = 4.35 R = 2.4	MOC-Application 878334-2	539635-1 416 Material 539797-2	2.5	4.9	6.5	21	0.9	828904-1	828922-1
1-927772-1	D 1-929931-1	CuSn4	FLR	0.2-0.5	E = 2.1 G = 2.1 D <sub>w</sub> = 0.8	H = 5.4 K = 4.6 D = 3.2	0.5mm <sup>2</sup> = 1.12 0.35mm <sup>2</sup> = 1.05 0.25mm <sup>2</sup> = 1.0 0.2mm <sup>2</sup> = 0.98	E = 1.7 G = 2.1 D <sub>w</sub> = 0.8	H = 4.2 K = 4.35 R = 2.4	MOC-Application 878334-2	539635-1 416 Material 539797-2	2.5	4.9	6.5	18.8	0.9	828904-1	828922-1

THIS DRAWING IS NOT SUBJECT TO CONSTANT CHANGING SERVICE AND DOES NOT LAY CLAIM TO BE COMPLETE. FOR DEFINITE SPECIFICATION SEE RESPECTIVE AMP CUSTOMER DRAWINGS. FURTHER VERSIONS ON INQUIRY.  
 Diese Zeichnung unterliegt nicht dem ständigen Änderungsdienst und erhebt keinen Anspruch auf Vollständigkeit. Verbindliche Angaben sind der jeweiligen AMP-Kundenzzeichnung zu entnehmen. Weitere Ausführungen auf Anfrage.

AMP Deutschland GmbH  
 D - 63225 Langen

PRODUCT GROUP DRAWING FOR JUNIOR POWER THER CONTACT  
 Produkt-Gruppen-Zeichnung fuer JPT Kontakt

AMP  
 105-18013  
 11-1-18050  
 A1 00779 (REPLACES 11E-1801E-002)

CUSTOMER DRAWING / KUNDENZEICHNUNG