

- REMARKS**  
 Bemerkungen
- 1 CONTACT BODY PRE SILVER PLATED MIN. 0.8µm CONTACT ZONE SELECTIVE PRE SILVER PLATED MIN. 3µm  
 Kontaktkörper vorversilbert min. 0.8µm Kontaktzone selektiv vorversilbert min. 3µm
  - 2 CONTACT ZONE GOLD PLATED MIN. 0.8µm OVER MIN. 1.3µm NI-LAYER CRIMP AREA MIN. 1µm TIN PLATED OVER NI-LAYER  
 Kontaktzone vergoldet min. 0.8µm über min. 1.3µm Ni-Zwischenschicht Crimpbereich min. 1µm verzinkt über Ni-Zwischenschicht
  - 3 CANTILEVER SPRING INSIDE AND OUTSIDE 0.4-1.2µm Au  
 Oberfeder innen und außen 0.4-1.2µm Au
  - 4 CONTACT BODY, CONTACT SPRING INSIDE AND CRIMP AREA MIN. 1µm TIN PLATED OVER NI-LAYER, TOUCHING AREA TO CANTILEVER SPRING AND CONTACT SPRING OUTSIDE SELECTIVE 0.8µm Au OVER MIN. 1.3µm NI-LAYER  
 Kontaktkörper, Kontaktfeder innen und Crimpbereich min. 1µm verzinkt über Ni-Zwischenschicht, Anlagefläche zur Oberfeder und Kontaktfeder aussen selektiv 0.8µm vergoldet über min. 1.3µm Ni-Zwischenschicht
  - 5 CONTACT ZONE AND TOUCHING AREA TO CANTILEVER SPRING MIN. 0.8µm SELECTIVE Au PLATED OVER 1.3µm NI PLATED, CRIMP AREA MIN. 1µm TIN PLATED OVER NI-LAYER  
 Kontaktzone und Anlagefläche zur Oberfeder min. 0.8µm vergoldet über min. 1.3µm Ni-Zwischenschicht Crimpbereich min. 1µm verzinkt über Ni-Zwischenschicht
  - 6 CONTACT BODY AND CRIMP AREA MIN. 1µm TIN PLATED OVER NI-LAYER, TOUCHING AREA TO CANTILEVER SPRING SELECTIVE 0.8µm Au OVER MIN. 1.3µm NI-LAYER  
 Kontaktkörper und Crimpbereich min. 1µm verzinkt über Ni-Zwischenschicht, Anlagefläche zur Oberfeder selektiv 0.8µm vergoldet über min. 1.3µm Ni-Zwischenschicht
  - 7 CUT OFF OPTIONAL  
 Abschnitt/Freisschnitt optional

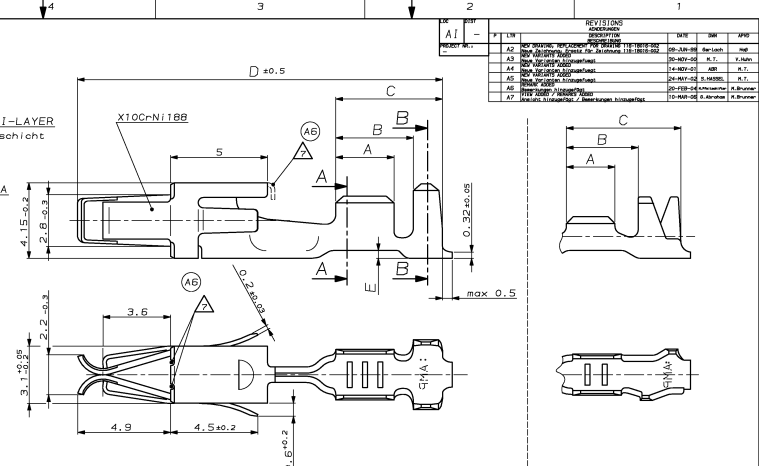

REV.	DATE	BY	CHK	APP
A1	20.08.2008	R.T.	J. K.	
A2	20.08.2008	R.T.	J. K.	
A3	20.08.2008	R.T.	J. K.	
A4	20.08.2008	R.T.	J. K.	
A5	20.08.2008	R.T.	J. K.	
A6	20.08.2008	R.T.	J. K.	
A7	20.08.2008	R.T.	J. K.	

ORDER-NO.	REV.	MATERIAL	SURFACE	DGB	SECTION A-A		SECTION B-B		WIRE CRIMP	SECTION A-A		SECTION B-B		APPLICATION TOOL	HAND TOOL	EXTRACTION TOOL	A	B	C	D	E
					Flank	FLR	Flank	FLR		Flank	FLR	Flank	FLR								
2-927773-1	P	2-927778-1	CuSn4	△	>1.0-2.5	FLK	E = 3.6 G = 3.8 D <sub>w</sub> = 1.8	H = 5.5 K = 5.8 D = 3.6	1.25mm² = 1.44 1.5mm² = 1.51 2.0mm² = 1.64 2.5mm² = 1.77	CH 20/8	E = 2.8 G = 3.9 D <sub>w</sub> = 1.7	H = 4.2 K = 5.2 r = 2.4	MGC-Applicator 878190-2	S39635-1 #11 Material S39674-2			3.3	4.3	5.8	18.8	0.4
1-927773-1	P	1-927778-1	CuFe2	△	>1.0-2.5	FLR	E = 3.6 G = 3.8 D <sub>w</sub> = 1.8	H = 4.7 K = 4.9 D = 2.6	1.25mm² = 1.44 1.5mm² = 1.51 2.0mm² = 1.64 2.5mm² = 1.77	CH 20/8	E = 2.8 G = 3.9 D <sub>w</sub> = 1.7	H = 3.8 K = 4.3 R = 2.3	MGC-Applicator 878190-2	S39635-1 #11 Material S39674-2			3.3	4.3	5.8	18.8	0.4
2-927768-1	R	2-927777-1	CuSn4	△	>1.0-2.5	FLR	E = 3.6 G = 3.8 D <sub>w</sub> = 1.8	H = 4.7 K = 4.9 D = 2.6	1.25mm² = 1.44 1.5mm² = 1.51 2.0mm² = 1.64 2.5mm² = 1.77	CH 20/8	E = 2.8 G = 3.9 D <sub>w</sub> = 1.7	H = 3.8 K = 4.3 R = 2.3	MGC-Applicator 878190-2	S39635-1 #11 Material S39674-2			3.3	4.3	5.8	18.8	0.4
1-927768-1	R	1-927777-1	CuFe2	△	>1.0-2.5	FLR	E = 3.6 G = 3.8 D <sub>w</sub> = 1.8	H = 4.7 K = 4.9 D = 2.6	1.25mm² = 1.44 1.5mm² = 1.51 2.0mm² = 1.64 2.5mm² = 1.77	CH 20/8	E = 2.8 G = 3.9 D <sub>w</sub> = 1.7	H = 3.8 K = 4.3 R = 2.3	MGC-Applicator 878190-2	S39635-1 #11 Material S39674-2			3.3	4.3	5.8	18.8	0.4
2-927771-2	N	2-927779-2	CuSn4	△	0.5-1.0	FLR	E = 2.6 G = 2.8 D <sub>w</sub> = 1.1	H = 3.6 K = 3.9 D = 1.8	0.5mm² = 1.18 0.75mm² = 1.27 1.0mm² = 1.36	CH 20/8	E = 2.2 G = 2.8 D <sub>w</sub> = 1.2	H = 2.8 K = 3.4 R = 1.6	MGC-Applicator 878181-2	S39635-1 #11 Material S39674-2			3	4	5.5	18.8	0.4
1-927771-1	N	1-927779-1	CuFe2	△	0.5-1.0	FLR	E = 2.6 G = 2.8 D <sub>w</sub> = 1.1	H = 3.6 K = 3.9 D = 1.8	0.5mm² = 1.18 0.75mm² = 1.27 1.0mm² = 1.36	CH 20/8	E = 2.2 G = 2.8 D <sub>w</sub> = 1.2	H = 2.8 K = 3.4 R = 1.6	MGC-Applicator 878181-2	S39635-1 #11 Material S39674-2			3	4	5.5	18.8	0.4
2-927774-1	C	2-927776-1	CuSn4	△	0.2-0.5	FLR	E = 2.1 G = 2.1 D <sub>w</sub> = 0.8	H = 2.7 K = 2.8 D = 1.4	0.2mm² = 0.98 0.25mm² = 1.00 0.35mm² = 1.05 0.5mm² = 1.12	CH 20/8	E = 1.7 G = 2.1 D <sub>w</sub> = 0.8	H = 2.2 K = 2.4 R = 1.3	MGC-Applicator 878332-2	S39635-1 #11 Material S39737-2			2.5	3.5	5.6	18.8	0.4
1-927774-1	C	1-927776-1	CuFe2	△	0.2-0.5	FLR	E = 2.1 G = 2.1 D <sub>w</sub> = 0.8	H = 2.7 K = 2.8 D = 1.4	0.2mm² = 0.98 0.25mm² = 1.00 0.35mm² = 1.05 0.5mm² = 1.12	CH 20/8	E = 1.7 G = 2.1 D <sub>w</sub> = 0.8	H = 2.2 K = 2.4 R = 1.3	MGC-Applicator 878332-2	S39635-1 #11 Material S39737-2			2.5	3.5	5.6	18.8	0.4
2-963708-1	C	2-963777-1	CuSn4	△	0.08-0.2	FLR	E = 1.7 G = 1.7 D <sub>w</sub> = 0.6	H = 3.1 K = 3.2 D = 1.6	0.08mm² = 0.79 0.14mm² = 0.83 0.22mm² = 0.87	CH 20/8	E = 1.5 G = 1.8 D <sub>w</sub> = 0.6	H = 2.5 K = 2.8 R = 1.4	MGC-Applicator 878599-2	734414-1			2.5	3.7	5.9	18.8	0.4
1-963708-1	C	1-963777-1	CuFe2	△	0.08-0.2	FLR	E = 1.7 G = 1.7 D <sub>w</sub> = 0.6	H = 3.1 K = 3.2 D = 1.6	0.08mm² = 0.79 0.14mm² = 0.83 0.22mm² = 0.87	CH 20/8	E = 1.5 G = 1.8 D <sub>w</sub> = 0.6	H = 2.5 K = 2.8 R = 1.4	MGC-Applicator 878599-2	734414-1			2.5	3.7	5.9	18.8	0.4
963708-6	B	963777-6	CuSn4	△	0.08-0.2	FLR	E = 1.7 G = 1.7 D <sub>w</sub> = 0.6	H = 3.1 K = 3.2 D = 1.6	0.08mm² = 0.79 0.14mm² = 0.83 0.22mm² = 0.87	CH 20/8	E = 1.5 G = 1.8 D <sub>w</sub> = 0.6	H = 2.5 K = 2.8 R = 1.4	MGC-Applicator 878599-2	734414-1			2.5	3.7	5.9	18.8	0.4
963708-3	B	963777-3	CuFe2	△	0.08-0.2	FLR	E = 1.7 G = 1.7 D <sub>w</sub> = 0.6	H = 3.1 K = 3.2 D = 1.6	0.08mm² = 0.79 0.14mm² = 0.83 0.22mm² = 0.87	CH 20/8	E = 1.5 G = 1.8 D <sub>w</sub> = 0.6	H = 2.5 K = 2.8 R = 1.4	MGC-Applicator 878599-2	734414-1			2.5	3.7	5.9	18.8	0.4
963708-1	B	963777-1	CuFe2	△	0.08-0.2	FLR	E = 1.7 G = 1.7 D <sub>w</sub> = 0.6	H = 3.1 K = 3.2 D = 1.6	0.08mm² = 0.79 0.14mm² = 0.83 0.22mm² = 0.87	CH 20/8	E = 1.5 G = 1.8 D <sub>w</sub> = 0.6	H = 2.5 K = 2.8 R = 1.4	MGC-Applicator 878599-2	734414-1			2.5	3.7	5.9	18.8	0.4

0.5-2.5mm²  
 0.08-0.5mm²  
**UNSEALED**  
 ungedichtet

THIS DRAWING IS NOT SUBJECT TO CONSTANT CHANGING SERVICE AND DOES NOT LAY CLAIM TO BE COMPLETE. FOR DEFINITE SPECIFICATION SEE RESPECTIVE AMP CUSTOMER DRAWINGS. FURTHER VERSIONS ON INQUIRY.

Diese Zeichnung unterliegt nicht dem ständigen Änderungsdienst und erhebt keinen Anspruch auf Vollständigkeit. Verbindliche Angaben sind der jeweiligen AMP-Kundenzeichnung zu entnehmen. Weitere Ausführungen auf Anfrage.

AMP DEUTSCHLAND GMBH 63225 LONGEN TEL: +49 69 30 00 00 FAX: +49 69 30 00 00 E-MAIL: AMP@AMP-DE.COM	G. Gerlach 07.10.2008 100-18013 100-18050	AMP DEUTSCHLAND GMBH 0 - 63225 LONGEN PRODUCT GROUP DRAWING FOR JUNIOR POWER TINES CONTACT Produkt-Gruppen-Zeichnung fuer: JPT Kontakt 1355046 (REPLACES 11E-1801E-002)
--	--	--

- REMARKS**  
 Bemerkungen
- CONTACT BODY PRE SILVER PLATED MIN. 0.8µm CONTACT ZONE SELECTIVE PRE SILVER PLATED MIN. 3µm  
 Kontaktkörper vorversilbert min. 0.8µm Kontaktzone selektiv vorversilbert min. 3µm
  - CONTACT ZONE GOLD PLATED MIN. 0.8µm OVER MIN. 1.3µm NI-LAYER CRIMP AREA MIN. 1µm TIN PLATED OVER NI-LAYER  
 Kontaktzone vergoldet min. 0.8µm über min. 1.3µm Ni-Zwischenschicht Crimpbereich min. 1µm verzinkt über Ni-Zwischenschicht
  - CANTILEVER SPRING INSIDE AND OUTSIDE 0.4-1.2µm Au  
 Oberfeder innen und außen 0.4-1.2µm Au
  - CONTACT BODY, CONTACT SPRING INSIDE AND CRIMP AREA MIN. 1µm TIN PLATED OVER NI-LAYER, TOUCHING AREA TO CANTILEVER SPRING AND CONTACT SPRING OUTSIDE SELECTIVE 0.8µm Au OVER MIN. 1.3µm NI-LAYER  
 Kontaktkörper, Kontaktfeder innen und Crimpbereich min. 1µm verzinkt über Ni-Zwischenschicht, Anlagefläche zur Oberfeder und Kontaktfeder aussen selektiv 0.8µm vergoldet über min. 1.3µm Ni-Zwischenschicht
  - CONTACT ZONE AND TOUCHING AREA TO CANTILEVER SPRING MIN. 0.8µm SELECTIVE Au PLATED OVER 1.3µm Ni PLATED, CRIMP AREA MIN. 1µm TIN PLATED OVER NI-LAYER  
 Kontaktzone und Anlagefläche zur Oberfeder min. 0.8µm vergoldet über min. 1.3µm Ni-Zwischenschicht Crimpbereich min. 1µm verzinkt über Ni-Zwischenschicht
  - CONTACT BODY AND CRIMP AREA MIN. 1µm TIN PLATED OVER NI-LAYER, TOUCHING AREA TO CANTILEVER SPRING SELECTIVE 0.8µm Au OVER MIN. 1.3µm NI-LAYER  
 Kontaktkörper und Crimpbereich min. 1µm verzinkt über Ni-Zwischenschicht, Anlagefläche zur Oberfeder selektiv 0.8µm vergoldet über min. 1.3µm Ni-Zwischenschicht
  - CUT OFF OPTIONAL  
 Abschnitt/Freischnitt optional

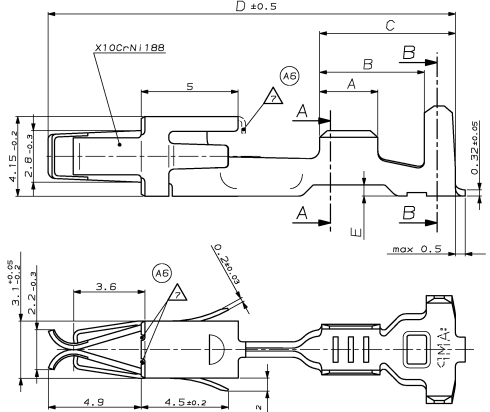

**SINGLE WIRE SEAL**  
 Einzel-Dichtungs-System

AMP ORDER-NO.	AMP ORDER-NO.	MATERIAL	SURFACE	DGB	WIRE CRIMP	WIRE CRIMP	WIRE CRIMP	WIRE CRIMP	WIRE CRIMP	AMP ORDER-NO.		AMP ORDER-NO.					
										FLK	FLR	FLK	FLR				
2-927766-1	E 2-929929-1	CuSn4	vorversilbert	>1.0-2.5	E = 3.6 H = 5.4 G = 3.8 D <sub>0</sub> = 1.8	H = 5.4 K = 4.6 D = 3.2	2.5mm <sup>2</sup> = 1.77 2.0mm <sup>2</sup> = 1.64 1.5mm <sup>2</sup> = 1.51	E = 2.8 H = 4.8 G = 3.9 D <sub>0</sub> = 1.7	MOC-Application 2-878845-2	539635-1 416 Material 539797-2	3.5	5.9	7.5	18.8	0.4	828905-1	828922-1
1-927766-1	E 1-929929-1	CuFe2	vorversilbert	>1.0-2.5	E = 3.6 H = 5.4 G = 3.8 D <sub>0</sub> = 1.8	H = 5.4 K = 4.6 D = 3.2	2.5mm <sup>2</sup> = 1.77 2.0mm <sup>2</sup> = 1.64 1.5mm <sup>2</sup> = 1.51	E = 2.8 H = 4.8 G = 3.9 D <sub>0</sub> = 1.7	MOC-Application 2-878845-2	539635-1 416 Material 539797-2	3.5	5.9	7.5	21	0.4	828905-1	828922-1
2-929937-1	D 2-929936-1	CuSn4	vorversilbert	0.5-1.0	E = 2.6 H = 5.4 G = 2.8 D <sub>0</sub> = 1.1	H = 5.4 K = 4.6 D = 3.2	1.0mm <sup>2</sup> = 1.36 0.75mm <sup>2</sup> = 1.27 0.5mm <sup>2</sup> = 1.18	E = 2.2 H = #4.6 G = 2.8 D <sub>0</sub> = 1.2	MOC-Application 878335-2	539635-1 416 Material 539797-2	3	5.4	7	21	0.6	828904-1	828922-1
2-929937-3	C 2-929936-3	CuSn4	vorversilbert	0.5-1.0	E = 2.6 H = 5.4 G = 2.8 D <sub>0</sub> = 1.1	H = 5.4 K = 4.6 D = 3.2	1.0mm <sup>2</sup> = 1.36 0.75mm <sup>2</sup> = 1.27 0.5mm <sup>2</sup> = 1.18	E = 2.2 H = #4.6 G = 2.8 D <sub>0</sub> = 1.2	MOC-Application 878335-2	539635-1 416 Material 539797-2	3	5.4	7	18.8	0.6	828904-1	828922-1
2-929941-1	D 2-929940-1	CuSn4	vorversilbert	0.2-0.5	E = 2.1 H = 5.4 G = 2.1 D <sub>0</sub> = 0.8	H = 5.4 K = 4.6 D = 3.2	0.5mm <sup>2</sup> = 1.12 0.35mm <sup>2</sup> = 1.05 0.25mm <sup>2</sup> = 1.0 0.2mm <sup>2</sup> = 0.98	E = 1.7 H = 4.2 G = 2.1 K = 4.35 D <sub>0</sub> = 0.8	MOC-Application 878334-2	539635-1 416 Material 539797-2	2.5	4.9	6.5	21	0.9	828904-1	828922-1
1-927772-1	D 1-929931-1	CuSn4	vorversilbert	0.2-0.5	E = 2.1 H = 5.4 G = 2.1 D <sub>0</sub> = 0.8	H = 5.4 K = 4.6 D = 3.2	0.5mm <sup>2</sup> = 1.12 0.35mm <sup>2</sup> = 1.05 0.25mm <sup>2</sup> = 1.0 0.2mm <sup>2</sup> = 0.98	E = 1.7 H = 4.2 G = 2.1 K = 4.35 D <sub>0</sub> = 0.8	MOC-Application 878334-2	539635-1 416 Material 539797-2	2.5	4.9	6.5	18.8	0.9	828904-1	828922-1

THIS DRAWING IS NOT SUBJECT TO CONSTANT CHANGING SERVICE AND DOES NOT LAY CLAIM TO BE COMPLETE. FOR DEFINITE SPECIFICATION SEE RESPECTIVE AMP CUSTOMER DRAWINGS. FURTHER VERSIONS ON INQUIRY.  
 Diese Zeichnung unterliegt nicht dem ständigen Änderungsdienst und erhebt keinen Anspruch auf Vollständigkeit. Verbindliche Angaben sind der jeweiligen AMP-Kundenzzeichnung zu entnehmen. Keine Ausführungen auf Anfrage.

AMP Deutschland GmbH  
 D - 63225 Langen

PRODUCT GROUP DRAWING FOR JUNIOR POWER THER CONTACT  
 Produkt-Gruppen-Zeichnung fuer: JPT Kontakt

105-18013  
 11-18050  
 A1 00779 (REPLACES 11E-1801E-002)

CUSTOMER DRAWING / KUNDENZEICHNUNG