

Miniature Circular Plastic Connectors (CPC)

DESCRIPTION

Revised 04/04 1309175

- Connector system available in wire-to-wire, wire-to-board and wire-to-panel configurations.
- Two shell sizes: Size 8 (1-4) or Size 11 (5-9) contact positions
- Utilizes existing Mini-Universal MATE-N-LOK stamped and formed contacts designed for up to 500 mating cycles when plated with gold or up to 50 cycles with tin plating.



APPLICATIONS

- Ideal for Industrial, Instrumentation and Transportation applications where size, contact density and environmental exposure are primary concerns.
- Nylon housings offer good resistance to a wide range of chemical agents while the IP67 sealing helps prevent ingress of dirt or fluids that could have an adverse effect on the contact interface.

KEY FEATURES

- Pre-positioned 1/4 turn coupling ring with positive lock and alignment features
- Unique contact pattern for each position size helps prevent accidental mating with other position sizes
- Sealed to IP67 (Protected against immersion in water up to 1 meter for 30 minutes)
- Front or rear jam nut mounting
- No assembly required
- Receptacle available in free-hanging or panel mount versions
- Alternate keys available

ELECTRICAL

- USR rated at 600 V, 7 A with 18 AWG wire per UL 1977
CNR rated at 600 V, 6 A with 18 AWG wire per C22.2 No. 182.3M-1987
USR/CNR rated at 600 V, 2 A with 30 AWG wire
- Dielectric withstanding voltage: 2200 VAC maximum

MECHANICAL

- Field repairable contacts
- Positive latching
- Housing: Single piece design, plastic
- Wire termination: Crimp
- Operating temperature: - 67°F to 221°F
[-55°C to +105°C]
- Mating application:
 - wire-to-wire
 - wire-to-panel (able to be sealed at the panel - jam nut mounting)
 - wire-to-board (vertical and right-angle)
 Note: Receptacles accept pin contacts and plugs accept socket contacts

STANDARDS & SPECS

- Design Objectives: 108-2079
- UL File No. E28476

FOR MORE INFORMATION

Technical Support

Internet: www.tycoelectronics.com
E-mail: newproducts@tycoelectronics.com

USA: 1-800-522-6752
Canada: 1-905-470-4425
Mexico: 01-800-733-8926
C. America: 52-55-5-792-0425

South America: 55-11-3611-1514
Hong Kong: 852-2735-1628
Japan: 81-44-844-8013
UK: 44-141-810-8967

new product

Miniature CPC

MATERIALS

- | | | | |
|---------------------|----------------------------|--------------------------|----------------------|
| • Seal, Wire Entry: | Elastomer, Yellow or White | • Ring, Coupling: | Thermoplastic, Black |
| • Seal, Peripheral: | Elastomer, Gray | • Nut, Jam | Brass, Nickel Plated |
| • Housing: | Thermoplastic, Black | • Plate, Seal Retention: | Thermoplastic, Black |
| • Protector, Seal: | Thermoplastic, Natural | | |

CABLE ASSEMBLIES

- Wide variety of custom discrete type cable assemblies, terminated with Terminals and Splices, Soft Shell, and Circular Plastic Connectors and other crimp and mass-terminated products.
- Capability to produce custom overmolded assemblies and insert and injection molding.
- Jacketed cable assemblies and discrete wire: Subminiature-D, SCSI, Circular Plastic, VHDCI, USB and Shielded Data Link
- For more information on our cable assembly capabilities, see our website at www.tycoelectronics.com/cables

PRODUCT DIMENSIONS

Shell Size 8 (4 Position shown)

Receptacle Assembly, Panel Mount
(Order pin contacts separately — see page 4)

Plug Assembly
(Order socket contacts separately — see page 4)

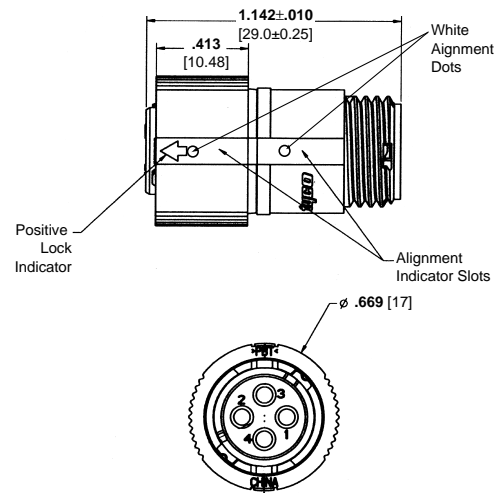
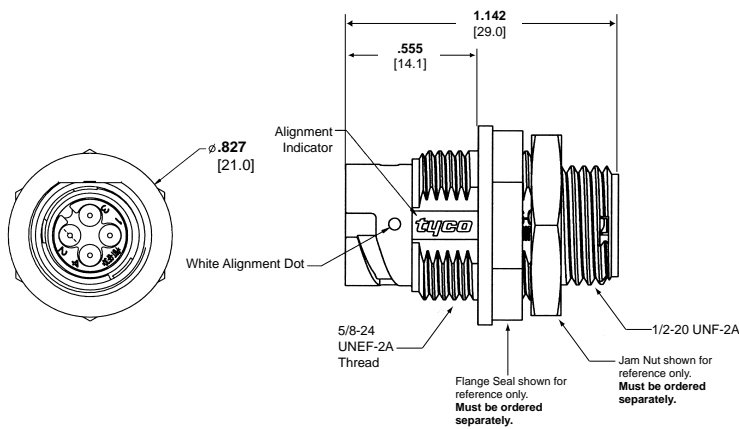

Receptacle Assembly, Free-Hanging
(Order pin contacts separately — see page 4)

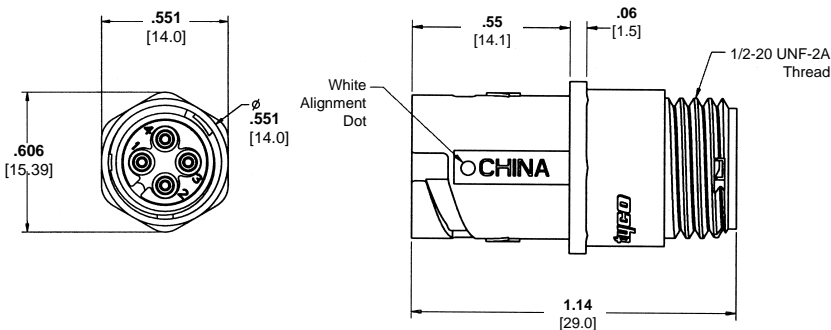

PRODUCT DIMENSIONS

Shell Size 11 (9 Position shown)

Receptacle Assembly, Panel-Mount
(Order pin contacts separately — see page 4)

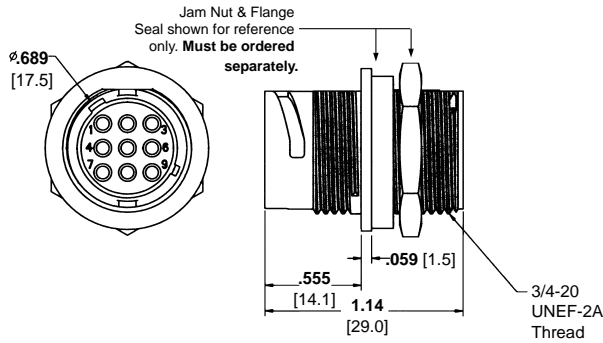

Plug Assembly
(Order socket contacts separately — see page 4)

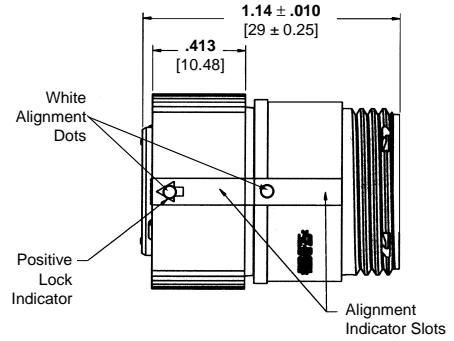

Receptacle Assembly, Free-Hanging
(Order pin contacts separately — see page 4)

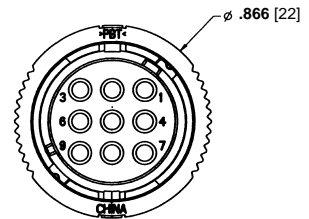
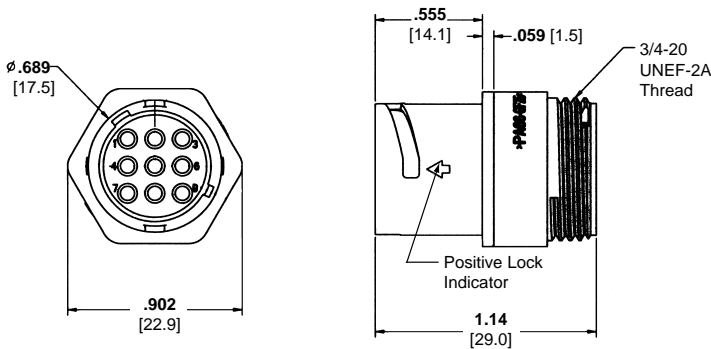

Accessories (Note: All accessories must be ordered separately.)

Strain Reliefs

Shell Size	Dimensions		Part Number	
	A	B	Straight	Right-Angle
8	.925 [23.5]	.709 [18.0]	1445730-1	1445771-1
11	1.10 [28.0]	.964 [24.5]	1445856-1	1546746-1 ¹ 1546746-2 ²

¹ Open Style

² With Cover

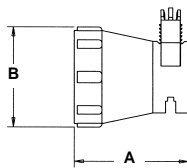

Jam Nuts

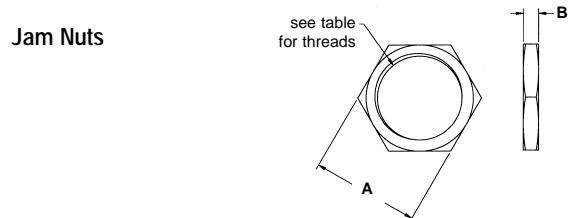

Shell Size	Dimensions		Thread	Part Number
	A	B		
8	.75 [19.0]	.125 [3.2]	5/8-24 UNEF-2B	1604196-1
11	.875 [22.25]	.125 [3.2]	3/4-20 UNEF-2B	1445904-1

Flange Seals

Shell Size	Dimensions		Part Number
	A	B	
8	.60 [15.3]	0.26 [6.6]	1445420-1
11	.73 [18.5]	0.33 [8.5]	1445420-2

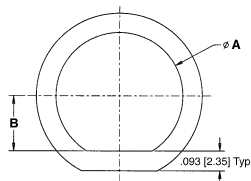

Dust Caps

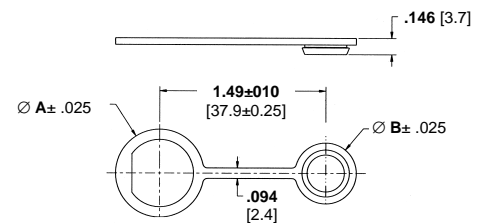

Heat Shrink Boots

Shell Size	Dimensions		Part Number
	A	B	
8	2.00 [50.8]	.75 [19.0]	1546997-1
11	2.50 [63.5]	1.00 [25.4]	1546921-1



Shell Size	Dimensions		Part Number
	A	B	
8	.795 [20.2]	.551 [14.0]	1604089-1
11	.89 [22.6]	.736 [18.7]	1604089-2

Miniature CPC

PRODUCT OFFERING

Housing Part Numbers

STANDARD STOCKED PART NUMBERS

Arrangement		Housing Part Numbers					
Shell Size	No. of Pos.	Insulation Diameter Range	Panel Mount Receptacle	Free-Hanging Receptacle	Posted, Vertical Receptacle	Posted, R-Angle Receptacle	Plug
8	1	.035-.059 [.89-1.5]*	1445539-1	1445526-1	1776009-1	1776016-1	1445536-1
		.059-.110 [1.5-2.39]	1445539-3	1445526-3			1445536-3
8	2	.035-.059 [.89-1.5]*	1445538-1	1445522-1	1776010-1	1776017-1	1445535-1
		.059-.110 [1.5-2.39]	1445538-3	1445522-3			1445535-3
8	3	.035-.059 [.89-1.5]*	1445537-1	1445510-1	1776011-1	1776018-1	1445534-1
		.059-.110 [1.5-2.39]	1445537-3	1445510-3			1445534-3
8	4	.035-.059 [.89-1.5]*	1445421-1	1445389-1	1445969-1	1604185-1	1445390-1
		.059-.110 [1.5-2.39]	1445421-3	1445389-3			1445390-3
11	5	.035-.059 [.89-1.5]*	1445824-1	1445829-1	1776012-1	1776019-1	1445820-1
		.059-.110 [1.5-2.39]	1445824-3	1445829-3			1445820-3
11	6	.035-.059 [.89-1.5]*	1445823-1	1445828-1	1738513-1	1776020-1	1445819-1
		.059-.110 [1.5-2.39]	1445823-3	1445828-3			1445819-3
11	7	.035-.059 [.89-1.5]*	1445822-1	1445827-1	1776013-1	1776021-1	1445818-1
		.059-.110 [1.5-2.39]	1445822-3	1445827-3			1445818-3
11	8	.035-.059 [.89-1.5]*	1445821-1	1445826-1	1776014-1	1776022-1	1445817-1
		.059-.110 [1.5-2.39]	1445821-3	1445826-3			1445817-3
11	9	.035-.059 [.89-1.5]*	1445816-1	1445825-1	1776015-1	1776023-1	1445807-1
		.059-.110 [1.5-2.39]	1445816-3	1445825-3			1445807-3

Note: Alternate keys available (115° part numbers shown in above chart)

*Insertion Tip (Seal Protector) Part No. 1604816-1 recommended for use when inserting socket contacts within this insulation range.

Contact and Tooling Part Numbers

Pin (for Receptacles)

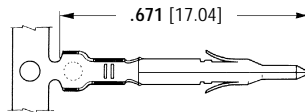

Socket (for Plugs)

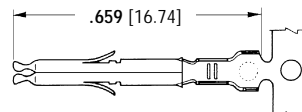

Contact Part Numbers

Wire Size Range AWG [mm²]	Ins. Dia. Range	Finish	Pin		Socket			HDM Applicator Part No.	Hand Tool Part No.
			Strip Form	Loose Piece	Brass Strip Form	Loose Piece	Phos. Bronze Strip Form		
30-26 [.05-.12]	.035-.050 .889-.127	Pre-tin Duplex ¹	770835-1	794059-1	770834-1	794058-1	770834-4	567418-1 ²	90717-2
			770835-3	794059-3	770834-3	794058-3	770834-6	567418-2 ² 567418-3 ²	or 90870-1 ⁴
26-22 [.12-.3]	.047-.069 1.19-1.75	Pre-tin Duplex ¹	770901-1	770985-1	770902-1	770986-1	770902-4	567066-3 ³	91529-1
			770901-3	770985-3	770902-3	770986-3	770902-6	567066-4 ³ 567066-5 ³	or 90758-1 ⁴
22-18 [.3-.8]	.059-.110 1.50-2.39	Pre-tin Duplex ¹	770903-1	770987-1	770904-1	770988-1	770904-4	567067-1 ²	91522-1
			770903-3	770987-3	770904-3	770988-3	770904-6	567067-2 ² 567067-3 ²	or 90759-1 ⁴

¹ Duplex Finish— Plated with .000030 [.000762] min. gold in mating area and .000100 [.00254] min. tin-lead in crimping area over .000050 [.00127] min. nickel underplate on entire contact

² HDM Applicator part number ending in -1 is used on AMPOMATOR CLS Machine with T or G Terminators, -2 is used on AMP-O-LECTRIC Model K Machine, -3 is used on AMP-O-LECTRIC Model G Machine.

³ HDM Applicator part number ending in -3 is used on AMPOMATOR CLS Machine with T or G Terminators, -4 is used on AMP-O-LECTRIC Model K Machine, -5 is used on AMP-O-LECTRIC Model G Machine.

⁴ Economy Hand Tool for Field Repair only.



Contact Extraction Tool
Part No. 189727-1
Instruction Sheet 408-4118



Contact Insertion Tool
(For inserting contacts applied to small diameter wire)
Part No. 455830-1
Instruction Sheet 408-7984



Insertion Tip (Seal Protector)
(For inserting socket contacts applied to small diameter wire)
Part No. 1604816-1