

tyco

Electronics

Precision Pin and Socket Contacts
Catalog 65910 Revised 1-03

AMP



Introduction

As the world's leading manufacturer of electrical/electronic connecting devices, Tyco Electronics produces a wide assortment of connector contacts. Included in this catalog is an array of the most popular pin and socket type contacts for signal and power, for coaxial cable, and posted versions for backpanel wiring applications. Also included is information on available application tooling to meet your production requirement.

The contacts present in this catalog were specifically designed for AMP M Series, CPC (Circular Plastic Connectors), Circular Metal-Shell, Metrimate (True Metric Dimensions), and "G" Series connectors.

How to choose the correct connector/contact combination.

Choosing the correct connector/contact combination is essential to the proper function of any AMP connector. A customer must first evaluate each individual application with regards to wire size(s), number of circuits, available space, and fastening method. The customer must then consider the following factors to make the right selection of connector/contact/hardware:

a. Connector Type. This decision is based on the selected contact types, coupling method, circuit density requirements and, if posted connectors are desired, in-plant production capabilities of wiring connectors using hand tools or semiautomatic tooling.

b. Contact Type. This decision is based on wire size(s) and the reliability and cost requirements of an application, as well as the customer's in-plant production capabilities.

c. Hardware Selection. This decision is based on the connector type, and the application requirements for fastening, protection, shielding, guiding, strain relief and keying.

For specific information on these connectors and associated hardware, refer to the following catalogs:

1. Catalog 82003—AMP M Series Pin and Socket Connectors
2. Catalog 82021—AMP CPC (Circular Plastic) and Metal-Shell CPC Pin and Socket Connectors
3. Catalog 82045—AMP Metrimate Pin and Socket Connectors
4. Catalog 82046—"G" Series Modular Connectors

Table of Contents

Introduction 2
 Current Carrying Capabilities 3, 4
 Contact Selection Chart 4
 Technical Document Selection Chart 4
 Contact Types 5-8

Signal Contacts

Type III+ (Precision Formed, Crimp, Snap-In) 9, 10
 Type III+ (Precision Formed, Solder and Solder Tab Type) 10, 11
 Type III+ (Precision Formed, Posted Type) 12
 Type II (Screw Machined, Crimp, Snap-In) 13
 Size 20 DF (Precision Formed, Crimp, Snap-In) 14, 15
 Size 20 DF (Precision Formed, Solder Cup, Snap-In) 16

Power Contacts

Type I, Size 12 (Screw Machined, Crimp, Snap-In) 17
 High Current Type II and Type III+ (Screw Machined, Crimp, Snap-In) 18
 High Current Size 20 (Screw Machined, Posted) 19
 High Current .125 POWERBAND (Precision Formed, Crimp, Snap-In) 20
 Standard Size 8 (Screw Machined, Crimp, Snap-In) 21
 High Current Size 8 (Screw Machined, Crimp, Snap-In) 22
 Type XII (Precision Formed, Crimp, Snap-In) 23
 High Current Type XII (Screw Machined, Crimp, Snap-In) 24

Coaxial Contacts

Subminiature Coaxial, Size 16 (Screw Machined, Crimp, Snap-In) 25, 26
 Miniature Coaxial, Size 12 (Screw Machined, Crimp, Snap-In) 27, 28
 Application Tooling and Numerical Index 29, 30
 Numerical Index (Product) 31

Need more information?

**Call Technical Support:
1-800-522-6752.**

The Center is staffed with specialists well versed in all AMP products and application tooling. The Center can provide you with:

- Technical Support
- Catalogs
- Technical Documents
- Product Samples
- AMP FAX Service—Product Information Faxed Immediately
- Authorized Distributor Locations

Produced under a Quality Management System certified to ISO 9001

A copy of the certificate is available upon request.



© 1994, 2000 and 2003 by Tyco Electronics Corporation. All Rights Reserved.

AMP, AMP FAX, AMPLIMITE, AMP-TAPETRONIC, AMP-O-LECTRIC, AMP-O-MATIC, AMPOMATOR, CERTI-CRIMP, LGH, POWERBAND, PRO-CRIMPER, TERMI-POINT and TYCO are trademarks.

Front Cover:
 CPC Connectors, Metrimate Connectors, M Series Connectors, 20 DF Contacts, Type II Contacts, Type III+ Contacts, Subminiature Coaxial Contacts, Miniature Coaxial Contacts, Type I Contacts, Type XII Contacts, Size 8 Contacts

Current Carrying Capabilities

Current Carrying Capabilities

The total current capacity of each contact in a given connector is dependent upon the heat rise resulting from the combination of electrical loads of the contacts in the connector arrangement and the maximum ambient temperature in which the connector will be operating. Caution must be taken to ensure that this combination of conditions does not cause the internal temperature of the connector to exceed the maximum operating temperature of the housing material. Several variables which must be considered when determining this maximum current capability for your application are:

- **Wire Size** —Larger wire will carry more current since it has less internal resistance to current flow and generates less heat. The wire also conducts heat away from the connector.
- **Connector Size**—In general, with more circuits in a connector, less current per contact can be carried.
- **Current Load Distribution** — Spreading those lines with greater current loads throughout the connector, particularly around the outer perimeter, will enhance heat dissipation.
- **Ambient Temperature** —With higher ambient temperatures, less current can be carried.

Current Rating Verification
Can a contact rated at 10 amperes carry 10 amperes?

Maybe yes, but probably not. The reason lies in the test conditions used to rate the contact. If these conditions do not adequately reflect the application conditions, the actual allowable current levels may be lower than specified levels. For example, many manufacturers, including Tyco, test a single contact in air. This gives an accurate measure of the basic current-carrying capacity of the contact. Use the contact alone in air and it can certainly carry 10 amperes. Use it in a multi-position connector surrounded by other current-carrying contacts or in high ambient temperatures, and the contact should carry less current.

Similarly, as the contact ages and stress relaxation, environmental cycling, and other degradation factors take their toll, the contact's current-carrying capacity decreases. A prudent design must set current levels for such end-of-design-life (EODL) conditions.

CONTACT CURRENT GUIDE Maximum Current (Amperes) for Largest Wire Size

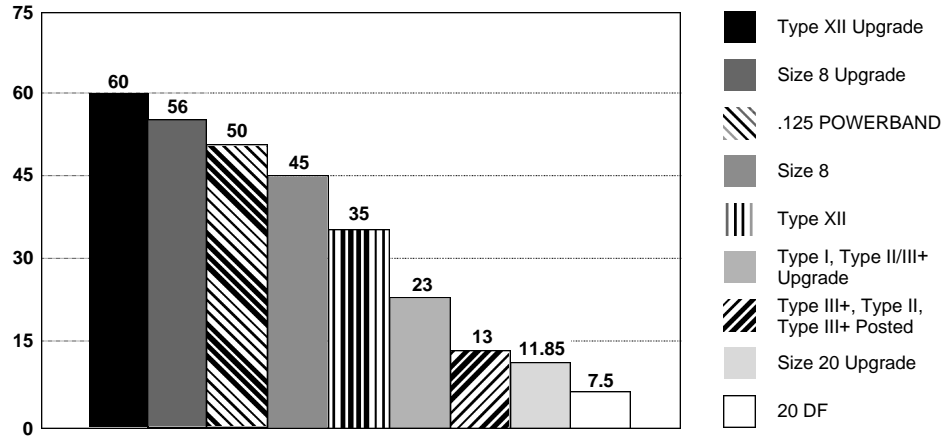

Practical current-carrying capacity is not an absolute, but an application-dependent condition.

New Method Simplifies Ratings

To help the designer set the appropriate current level, Tyco Electronics has developed a method of specifying current-carrying capacity. This method takes into account the various application factors that influence current rating.

The method can be summarized as follows:

- The contact is aged to EODL conditions by durability cycling, thermal cycling, and environmental exposure.
- The contact's resistance stability is verified.
- The current necessary to produce the specified temperature rise is measured. This T-rise is usually 30°C.
- A rating factor is determined to allow derating of multiple contacts in the same housing and for different conductor sizes.

Temperature

One other factor influencing current levels is the maximum operating temperature, for example, 105°C. If the application has a high ambient temperature (over 75°C) the contact's T-rise is limited by the maximum operating temperature. For example, an application temperature of 90°C limits the contact T-rise to 15°C. Since current produces heat (the I²R law), the current must be lowered to limit the T-rise.

A contact's T-rise depends not only on its I²R Joule heating, but also on its ability to dissipate the heat. Consider a contact in a multi-contact housing. Joule heating in multiple contacts will raise the local ambient temperature. Since the contact will not be able to dissipate its own heat

as well by convection, the maximum T-rise will be realized at a lower current level. Consequently, the allowable current level must be lower to maintain an acceptable T-rise.

For a given connector, the current level will be set by the loading density. A connector containing 50% current-carrying contacts will permit higher currents (per contact) than a connector will at 75% loading. The loading percentage assumes an even distribution of contacts within the housing. If all 10 contacts are grouped together in one section of a 20-position connector, the loading density may approach 100%.

The Importance of EODL

As stated, T-rise in a contact depends on both resistance and current. As it ages, a contact's resistance will increase. The contact designer will specify a maximum resistance for the contact, this level is the end-of-design-life resistance. Before the contact is tested for current, Tyco subjects it to a sequence

of tests that exercises the major failure mechanisms and thereby simulates EODL conditions. Conditioning includes mating cycling, industrial mixed-flowing gases, humidity and temperature cycling, and vibration to sequentially introduce wear, corrosion, stress relaxation, and mechanical disturbance.

Presentation

The presentation of current-carrying capacity in AMP product specifications includes two parts:

- First, a base curve showing current levels versus T-rise for a single circuit and the largest wire size. This represents the maximum current capacity of the contact. The curve is usually flat up to 75°C ambient and then drops off. Up to 75°C, the 30°C T-rise limits the amount of current, and above 75°C the current must be reduced to keep the combination of ambient temperature and T-rise from exceeding the maximum operating temperature of 105°C.

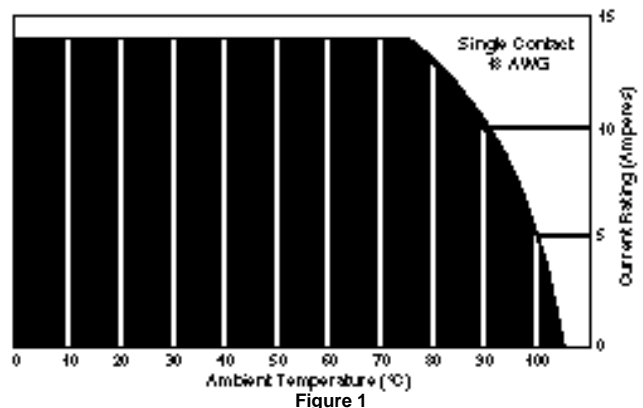

Graph shows the relationship between base current, ambient temperature, and contact T-rise.

Current Carrying Capabilities (Continued)

Next are rating factors, a table of multipliers to account for connector loading and for smaller wire sizes. The designer first determines the base current for the ambient conditions of the application; then multiplies this base current by the rating factors to find the current level for the application's loading factor and wire size.

Practical Values

The current-rating method gives designers practical values applicable to their applications. While the specified current levels for a contact may be lower than for other testing methods, they are more realistic and simplify the system design process.

"Spec-manship" is replaced by a realistic assessment of the current-carrying capacity of a contact under varying conditions of temperature, connector loading, and wire size.

An Example:

To demonstrate the method of specifying current, consider the following application conditions; an ambient temperature of 65°C, a 50% loading of contacts in the housing, and 20 AWG [0.6mm²] wire.

- From Figure 1, the base current rating is 14 ampere with 18 AWG [0.8mm²] wire.
- Figure 2, the rating factor for 50% loading and 20 AWG [0.6mm²] wire is 0.68.
- The specific rating for this application is the product of the base rating and the rating factor:
14 x 0.68 = 9.5 ampere
- Each of the contacts can carry 9.5 ampere.
- However, if the ambient temperature is 80°C the allowable T-rise becomes 25°C. The base current must be lowered to 12.8 ampere so that the 105°C maximum operating temperature is not exceeded. The current rating then becomes:
12.8 x 0.68 = 8.7 ampere.

		AWG				
		18	20	22	24	26
% Loading	Single	1	.83	.69	.59	.50
	30%	.97	.80	.66	.57	.49
	50%	.83	.68	.57	.48	.42
	70%	.65	.53	.45	.38	.33
	100%	.55	.45	.38	.32	.28

Figure 2

Rating factors allow the base current to be adjusted for various connector loading and wire sizes.

Connector/Contact Acceptability

As previously stated, choosing the correct connector/contact combination is fundamental to the successful function of all connectors. The Selection Chart shown below, is designed to simplify your choice of connectors and their acceptable contacts. Once you have selected the wire size, current-carrying capacity need, number of positions required, and the type of contacts needed in your choice of connector, refer to this matrix for a quick look at exactly what is acceptable in a given connector type.

Technical Documents

Technical Documents consist of *Product Specifications* and *Application Specifications*. *Product Specifications* define the performance characteristics of the product; i.e., Current Rating, Temperature Rating, etc. They are intended for the Design or Component Engineer. *Application Specifications* describe how the product is to be applied; i.e., Crimping, Assembling, etc. They are intended for Manufacturing and Operation/Set Up Personnel. Where Application Specifications are not available, an Instruction Sheet is provided. Additional Instruction Sheets on the product may be available. Please contact Technical Support: 1-800-522-6752.

Technical Document Selection Chart

Contact Type	Product Specifications	Application Specifications	Instruction Sheet
20 DF	108-40005	114-10000 114-40030	—
Type I	108-10108	114-10037	—
Type II	108-10039	114-10026	—
Type III+	108-10042	114-10004	—
Type VI	108-10038	114-10007	—
Type XII	108-10037	114-10005	—
M Series Posted	108-10042	—	408-09155
.125 POWERBAND	—	114-10043	—
Size 8	108-01317	114-10014	—
Size 8 Upgrade	108-1449	—	—
Mini Coax	108-12021	—	408-1770
Sub-Mini Coax	108-12008 108-12011	—	408-2024-3

Contact Selection Chart

Connector Type	20 DF & Size 20 Upgrade	Type I	Type II	Type III+ & Type II/III+ Upgrade	Posted Type III+	Type XII & Type XII Upgrade	.125 POWERBAND	Size 8 & Size 8 Upgrade	Mini-Coax	Sub-Mini Coax
Metrimate			✓	✓	✓					
Metrimate Drawer			✓	✓	✓			✓		
Metrimate Drawer (.125 POWERBAND)							✓			
CPCSeries 1			✓	✓	✓					✓
CPC Series 2	✓									
CPC Series 3						✓				
CPC Series 4			✓	✓		✓				✓
CPCSeries 5							✓			
CPCSeries 6			✓	✓			✓			
M Series			✓	✓	✓					✓
M Series Special		✓	✓	✓	✓	✓			✓	✓
"G" Series		✓	✓	✓		✓			✓	

Signal Contacts

Type III+, Crimp, Snap-In, Size 16

Precision formed pin and socket contacts in Size 16. They are used in M Series, Special M Series, "G" Series, Metrimate, Metrimate Drawer, and CPC Series 1 and 4 connectors. Contacts feature a high normal force which provides a low resistance in significant applications such as dry circuit signal conditions. Mating entry is closed-ended to prevent damage from stubbing due to misalignment. Stainless steel spring provides superior normal force and retention in the housing. Tyco Electronics proprietary gold plating process is designed so that specified plating thicknesses are controlled on the inside of the socket, which is the critical contact mating area. The contacts are formed from brass. Single contact rating is 13 amperes at 30°C T-Rise.

See page 9 for product details.

Type III+, Solder Type, Size 16

As with the crimp snap-in Type III+, these precision formed solder-type contacts are also used in M Series, Special M Series, Metrimate, Metrimate Drawer, and CPC Series 1 and 4 connectors. Contacts feature a high normal force which provides a low resistance in significant applications, such as dry circuit conditions. A preformed wire barrel accepts both stranded and solid wire, while the preformed insulation barrel provides strain relief for various wire insulation thicknesses. Mating entry is closed-ended to prevent damage from stubbing due to misalignment. A stainless steel spring provides superior normal force and retention in the housing. Tyco Electronics proprietary gold plating process is designed so that specified plating thicknesses are controlled on the inside of the socket, which is the critical contact area. Single contact current rating is 13 amperes at 30°C Temperature Rise.

See page 10 for product details.

Type III+, Solder Tab, Size 16

A companion contact style to the crimp snap-in and solder-type, the Type III+ Solder Tab is compatible with the same AMP connector families, and features high normal forces to provide a low resistance in significant applications. A pre-crimped solder tab with slot accepts various sizes of solid and stranded wire. Mating entry is closed-ended to prevent stubbing due to misalignment. A stainless steel spring provides superior normal force and retention in the housing. Tyco Electronics proprietary gold plating process is designed so that specified plating thicknesses are controlled on the inside of the socket, which is the critical contact area. Single contact current rating is 13 amperes at 30°C Temperature Rise.

See page 11 for product details.

Signal Contacts (Continued)

Type III+, Posted Version, Size 16

The last member of the Type III+ family of contacts, the posted version is compatible with M Series, Special M Series, Metrimate, Metrimate Drawer, and CPC Series 1 connectors. Precision formed, they are pre-crimped to various post configurations including those that accept TERMI-POINT Clip or wire-wrap type terminations. Contacts feature high normal force which provides a low resistance in significant applications. Mating entry is closed-ended to prevent damage from stubbing due to misalignment. A stainless steel spring provides superior normal force and retention in the housing. Tyco Electronics proprietary gold plating process is designed so that specified plating thicknesses are controlled on the inside of the socket, which is the critical contact mating area. Contacts are formed from brass. Single contact current rating is 13 amperes at 30°C Temperature Rise.

See page 12 for product details.

Type II, Crimp, Snap-In, Size 16

Precision screw-machined pin and socket contacts, they are used in M Series, Special M Series, "G" Series, Metrimate, Metrimate Drawer, and CPC Series 1 and 4 connectors. Contacts feature high normal force which provides a low resistance in significant applications such as dry circuit signal conditions. Mating entry is closed-ended to prevent damage from stubbing due to misalignment. A stainless steel spring provides superior normal force and retention in the housing. The contact bodies are machined from solid brass. Single contact current rating is 13 amperes at 30°C Temperature Rise.

See page 13 for product details.

Size 20 DF, Crimp, Snap-In

Precision formed lance-less pin and socket, crimp, snap-in contacts in Size 20. These contacts are used in CPC Series 2 and AMPLIMITE Subminiature D connectors (see catalog 82068 for AMPLIMITE connectors). Contacts feature a low mating force to facilitate high pin counts in the connector housings. Tulip entry design on socket and generous lead-in on pin prevents contact stubbing. Pin contacts are formed from brass, whereas socket contacts are formed from phosphor bronze providing excellent spring properties. Contacts are available with or without insulation support. Single contact current rating is 7.5 amperes at 30°C Temperature Rise.

See pages 14 & 15 for product details.

Size 20 DF, Solder Cup, Snap-In

Precision formed lance-less pin and socket, solder contacts in Size 20. These contacts are used in CPC Series 2 and AMPLIMITE Subminiature D Connectors (see catalog 82068 for AMPLIMITE connectors). Contacts feature a low mating force to facilitate high pin counts in the connector housings. Tulip entry design on socket and generous lead-in on pin prevents contact stubbing. Pin contacts are formed from brass, whereas sockets are formed from phosphor bronze providing excellent spring properties. Contacts may be soldered to solid or stranded wire up to 18 AWG [0.8 mm²] maximum. Single contact current rating is 7.5 amperes at 30°C Temperature Rise.

See page 16 for product details.

Power Contacts

Type I, Crimp, Snap-In, Size 12

Precision screw-machined pin and socket, Size 12 contacts, they are used in Special M Series and "G" Series connectors, and are inserted into the same cavities as Miniature Coaxial contacts. These contacts feature a high normal force which provides a low resistance in significant applications. Mating entry is closed-ended to prevent damage from stubbing due to misalignment.

Beryllium copper springs are used to provide contact normal force and are assisted by a stainless steel hood which provides anti-overstress assurance. Single contact current rating is 23 amperes at 30°C Temperature Rise.

See page 17 for product details.

.125 POWERBAND, Crimp, Snap-In

Specifically designed for AMP CPC Connectors (Series 5 and 6) and Metrimate .125 POWERBAND Drawer Connectors, the new .125 POWERBAND contact offers the performance of a MIL-Spec screw machine contact with the economy of a stamped and formed, strip-feed contact. Contacts are formed from copper with beryllium copper springs. Single contact current rating is 50 amperes at 30°C Temperature Rise.

See page 20 for product details.

Size 8, 4/8 Indent Crimp

Precision screw-machined pin and socket, Size 8 contacts, they are used in Metrimate Drawer Connectors, and other AMP product lines, which require high current carrying capability in a small size. Pins are made from a solid high conductivity copper alloy, and the sockets are machined from solid beryllium copper, a material which exhibits excellent spring properties. Industry standard 4/8 indent crimp offers higher reliability and ease of termination. Single contact current rating is 45 amperes at 30°C Temperature Rise.

See page 21 for product details.

Type XII, Crimp-Type

Precision formed male and female contacts used in CPC Series 3 and 4, Special M Series and "G" Series connectors, these contacts offer a low cost power option which provides additional applied cost savings when terminated with semiautomatic application equipment. The contact body is made from 100% copper, which provides for excellent conductivity. Spring characteristics are derived from a captive stainless steel spring which assists the dual cantilever spring members of the female contact. Single contact current rating is 35 amperes at 30°C Temperature Rise.

See page 23 for product details.

High Current Upgrades

Precision screw-machined pin and socket contacts have increased current capability. All upgraded contacts use the high amperage Louvertac contact band. The design of this contact allows for increased current in the same form factor. For example, Type II/Type III+ upgraded contacts increase the current from 13 amperes free air to 23 amperes free air at a 30°C Temperature Rise.

See pages 18, 19, 22, and 24 for further details.

Coaxial Contacts

Subminiature, Crimp, Snap-In, Size 16

Precision screw-machined pin and socket, Size 16 contacts, they are used in M Series, Special M Series, and CPC Series 1 and 4. They provide cost effective solutions in applications where mixtures of signal, power, and coaxial cable terminations are desired. The contact outer shell is made from brass, while the center pin conductor is beryllium copper, and the socket is brass. Both the pin and socket center conductor are gold plated for maximum corrosion resistance and minimum contact resistance. The retention spring is stainless steel, while the ferrule is tin-lead plated copper. Contact design offers application of coaxial cable, shielded conductors, and twisted pair wire with a voltage rating of up to 200 VRMS, and a current rating of 1.0 ampere at 30°C Temperature Rise.

See pages 25 & 26 for product details.

Miniature, Crimp, Snap-In, Size 12

Precision screw-machined, Size 12 pin and socket contacts, they are used in Special M Series and "G" Series connectors. They provide cost effective solutions in applications where a mixture of signal, power, and coaxial cable terminations is desirable. Contact body and center wire conductor are made from brass, and are gold plated for maximum corrosion resistance and minimum contact resistance. The retention spring is beryllium copper, and the ferrule is tin-lead plated copper. Contact design offers application of coaxial cable, shielded conductors, and twisted pair wire with a voltage rating of up to 325 VRMS, and a current rating of 7.5 amperes at 30°C Temperature Rise.

See pages 27 & 28 for product details.

Signal Contacts

Type III+, Crimp, Snap-In

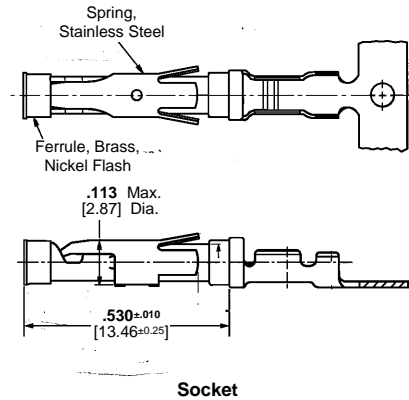
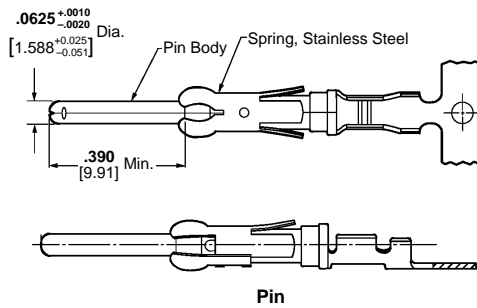
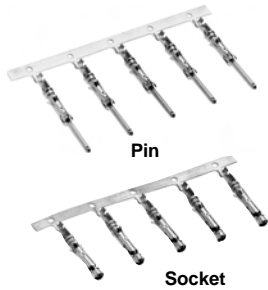

Material

Contact Body—Brass or phosphor bronze
Retention Spring—Stainless steel

Finish

See chart.

Related Product Data

Application Tooling—Pages 29, 30

Technical Documents

114-10004 Application Specification
 108-10042 Product Specification

Contact Size 16—Pin Diameter .062 [1.57] (Test Current, 13 Ampere)‡

AWG	Wire Size Range mm ²	Ins. Dia. Range	Contact Finish	Strip Form Contact No.		Loose Piece Contact No.		Tooling Part No.			
				Pin	Socket	Pin	Socket	Loose Piece Hand Tool	Strip Form Applicators		
30-28	0.05-0.09	.015-.030 0.38-0.76	Gold/Nickel ²	788085-3	788088-2	—	—	90716-1	567867-1*** or 567947-1*** or 680602-□***		
			Sel. Gold/Nickel ³	788085-1	788088-1	788085-4	788088-3		—	—	
			Bright Tin-Lead	66425-6	66424-6	—	—		—	—	
30-26	0.05-0.15	.040-.060 ¹ 1.02-1.52	Gold/Nickel ²	66425-7	66424-7	66429-3	66428-3	91515-1 ⁶	466598-□***		
			Sel. Gold/Nickel ³	66425-8	66424-8	66429-4	66428-4			—	—
			Bright Tin-Lead	66393-7	66394-7	—	—			—	—
26-24	0.12-0.2	.035-.055 ¹ 0.89-1.40	Gold/Nickel ²	66393-8	66394-8	66406-4	66405-4	90225-2 ⁶	466585-3***		
			Sel. Gold/Nickel ³	66393-8	66394-8	66406-4	66405-4			—	—
			Bright Tin-Lead	66106-6	66108-6	66107-2	66109-2			—	—
24-20	0.2-0.6	.080-.100 ¹ 2.03-2.54	Gold/Nickel ²	66106-7	66108-7	66107-3	66109-3	91515-1 ⁶ or 58495-1*	466321-□*** or 466908-2***		
			Sel. Gold/Nickel ³	66106-7	66108-7	66107-4	66109-4			—	—
			Bright Tin-Lead	66102-7	66104-7	66103-2	66105-2			—	—
18-16	0.8-1.4	.080-.100 ¹ 2.03-2.54	Gold/Nickel ²	66102-8	66104-8	66103-3	66105-3	91515-1 ⁶ or 58495-1*	466323-□*** or 466907-2***		
			Sel. Gold/Nickel ³	66102-9	66104-9	66103-4	66105-4			—	—
			Bright Tin-Lead	2-66102-2	2-66104-3	1-66103-2	1-66105-3			—	—
24-20	0.2-0.6	.060-.120 ⁵ 1.52-3.05	Gold/Nickel ²	66104-1	66105-1	66105-1	66105-1	91542-1 ⁶	466383-4*** or 466979-1*** or 567363-□***		
			Sel. Gold/Nickel ³	66564-6	66563-6	66566-2	66565-2			—	—
			Bright Tin-Lead	66564-8	66563-8	66566-4	66565-4			—	—
18-14	0.8-2.0	.080-.100 ¹ 2.03-2.54	Gold/Nickel ²	66564-1	66566-1	66566-1	66566-1	91523-1 ⁶ or 90225-2 ⁶	466324-□*** or 466942-1***		
			Sel. Gold/Nickel ³	66332-5	66331-5	66400-1	66399-1			—	—
			Bright Tin-Lead	66332-7	66331-7	66400-3	66399-3			—	—
18-14	0.8-2.0	.110-.150 ⁵ 2.79-3.81	Gold/Nickel ²	66332-8	66331-8	66400-4	66399-4	91521-1 ⁶	466958-1*** or 567364-□***		
			Sel. Gold/Nickel ³	66332-8	66331-8	66400-4	66399-4			—	—
			Bright Tin-Lead	66331-2	66399-2	66399-2	66101-2			—	—
18-14	0.8-2.0	.080-.100 ¹ 2.03-2.54	Gold/Nickel ²	66098-2 ⁵	66100-7	66099-2	66101-2	91505-1 ⁶ or 91523-1 ⁶ or 58495-1*	466325-□*** or 466906-1***		
			Sel. Gold/Nickel ³	66098-7	66100-8	66099-3	66101-3			—	—
			Bright Tin-Lead	66098-8	66100-9	66099-4	66101-4			—	—
18-14	0.8-2.0	.080-.100 ¹ 2.03-2.54	Gold/Nickel ²	66098-6	66100-9	66099-1	66101-4	91519-1 ⁶	466326-□*** or 466923-2***		
			Sel. Gold/Nickel ³	66359-6	66358-6	66361-2	66360-2			—	—
			Bright Tin-Lead	1-66359-1	1-66358-2	66361-7	66360-7			—	—
18-14	0.8-2.0	.080-.100 ¹ 2.03-2.54	Gold/Nickel ²	66359-9	66358-9	66361-3	66360-3	91519-1 ⁶	466326-□*** or 466923-2***		
			Sel. Gold/Nickel ³	1-66359-0	1-66358-0	66361-4	66360-4			—	—
			Bright Tin-Lead	1-66359-2	1-66358-3	66361-8	66360-8			—	—
18-14	0.8-2.0	.110-.150 ⁵ 2.79-3.81	Gold/Nickel ²	66358-1	66360-1	66360-1	66360-1	91521-1 ⁶	466958-1*** or 567364-□***		
			Sel. Gold/Nickel ³	66597-1	66598-1	66602-1	66601-1			—	—
			Bright Tin-Lead	66597-2	66598-2	66602-2	66601-2			—	—

¹Overall insulation crimp diameter, including crimp barrel, must not exceed .125 [3.18].
²0.00015 [0.00038] gold in the mating area over .000050 [0.00127] min. nickel.
³0.00030 [0.00076] gold in the mating area, with gold flash on remainder, over .000050 [0.00127] min. nickel.
⁴0.00030 [0.00076] gold in the mating area, with gold gradient on remainder, over .000050 [0.00127] min. nickel.
⁵Contacts can only be used in Metrimate and CPC Series 1 (Arr. 23-24), Series 4 (Arr. 23-13M, 23-16M, 23-22M), and VDE connectors.

⁶To use with the 626 Pneumatic Tool System: remove the crimping head from the Straight Action Hand Tool (SAHT) Assembly, order SAHT Adapter Part No. (Call Technical Support at 800-522-6752), Adapter Holder Part No. 356304-1 (with ratchet) or 189928-1 (without), and Power Unit Part No. 189721-1 (hand actuated) or 189722-1 (foot actuated).
⁷Standard reeling of strip form contacts.
⁸Commercial PRO-CRIMPER II hand tool for field repair only. Note: Die Set can be adapted for use with the 626 Pneumatic Tool System.

‡Single contact, free-air test current is not to be construed as contact rating current. Use only for testing. Refer to contact current carrying capability information on page 3.
Insertion Tool Part No. 91002-1 (for insulation diameters .070 [1.78] or less), **No. 200893-2** (for insulation diameters .090 [2.29] max.).
Extraction Tool Part No. 305183. (Instruction Sheet 408-1216)
 ***Call Technical Support at 1-800-522-6752 for Automatic Machine Applicator Part Numbers.

Dimensions are in inches and millimeters unless otherwise specified. Values in brackets are metric equivalents.

Dimensions are shown for reference purposes only. Specifications subject to change.

Technical Support
 USA: 1-800-522-6752
 Canada: 1-905-475-6222
 Mexico: 01-800-733-8926

Central America: 52-55-5-729-0425
 South America: 55-11-3611-1514
 www.tycoelectronics.com

Signal Contacts (Continued)

Type III+, Crimp, Snap-In

Contact Size—16
Pin Diameter—.062 [1.57]

Material and Finish

Contact Body—Copper alloy, plated tin or gold
Spring—Stainless steel

Grounding Pin
 (make first - break last)

Related Product Data

Application Tooling—Pages 29, 30
Technical Documents—Page 4

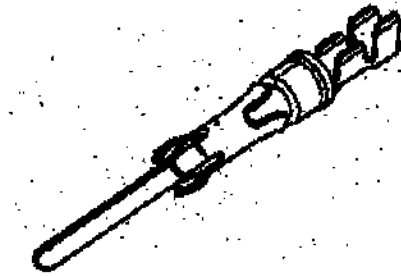

Wire Size Range		Ins. Dia. Range ¹	Contact Finish	Grounding Pin Part No.		Strip Form Applicator Part No.	Loose Piece Hand Tool Part No.
[mm ²]	AWG			Strip Form	Loose Piece		
0.12-0.2	26-24	.035-.055 0.89-1.4	Tin-Lead	164159-3	164162-1	—	91515-1 ³ or 58495-1*
			Sel. Gold/Nickel ²	164159-4	164162-2		
0.2-0.6	24-20	.045-.070 1.14-1.78	Bright Tin-Lead	164160-3	164163-1	466323-□***	91515-1 ³ or 91505-1 ³ or 58495-1*
			Sel. Gold/Nickel ²	164160-4	164163-2	466907-2***	
0.8-1.4	18-16	.078-.098 1.98-2.49	Tin-Lead	164161-3	164164-1	466741-□***	91523-1 ³ or 91505-1 ³ or 58495-1*
			Sel. Gold/Nickel ²	164161-4	164164-2	680114-3***	

¹Overall insulation crimp diameter, including crimp barrel, must not exceed .125 [3.18].

²Gold flash over .000030 [0.00076] min. nickel on entire contact, with .000030 [0.00076] gold in contact area.

³To use with the 626 Pneumatic Tool System: remove the crimping head from the Straight Action Hand Tool (SAHT) Assembly, order SAHT Adapter **Part No. (Call Technical Support at 800-522-6752)**, Adapter Holder **Part No. 356304-1** (with ratchet) or **189928-1** (without), and Power Unit **PartNo. 189721-1** (hand actuated) or **189722-1** (foot actuated).

*Commercial PRO-CRIMPER II hand tool for field repair only. **Note:** Die Set can be adapted for use with the 626 Pneumatic Tool System.

***Call Technical Support at 1-800-522-6752 for Automatic Machine Applicator Part Numbers.

Extraction Tool Part No. 725840-1

Type III+, Solder Versions



Pin



Socket

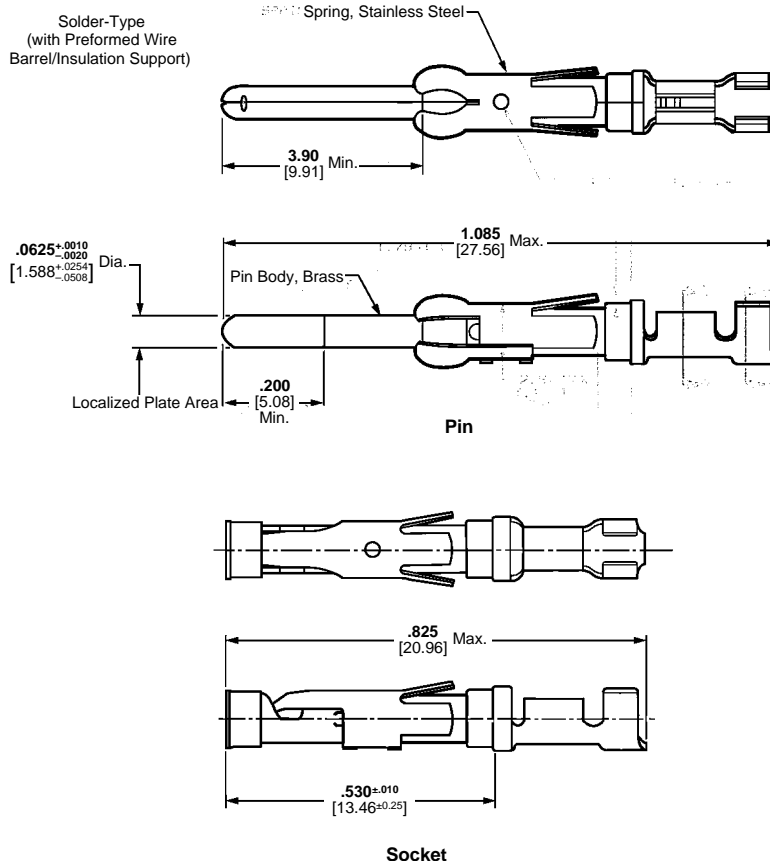

Material

Contact Body and Tab—Brass
Retention Spring—Stainless steel

Finish

See chart on Page 11.

Signal Contacts (Continued)

Type III+, Solder Versions (Continued)



Pin



Socket

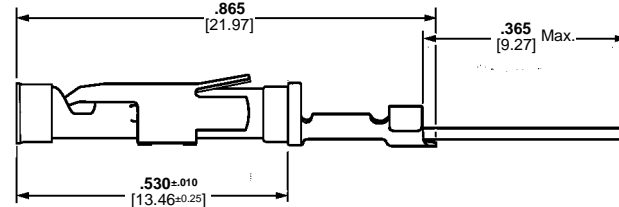
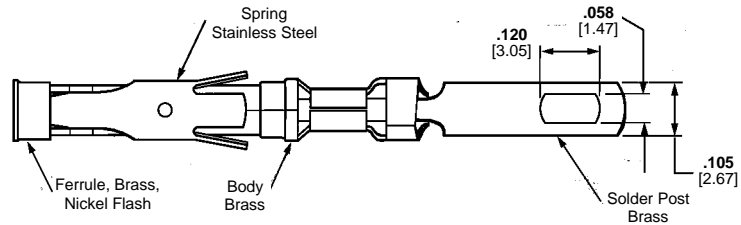
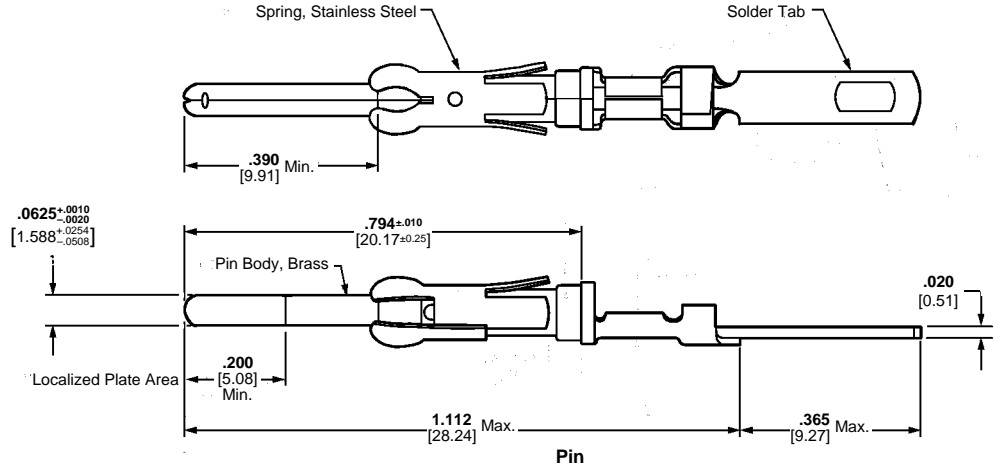

Socket

Material

Contact Body and Tab—Brass
Retention Spring—Stainless steel

Finish

See chart.

Contact Size 16—Pin Diameter .062 [1.57] (Test Current, 13 Ampere)‡

Wire Size Range		Contact Finish	Loose Piece Contact No.	
AWG	[mm ²]		Pin	Socket
26-20	0.12-0.6	Gold/Nickel ¹	66182-1	66183-1
18-16	0.8-1.4	Gold/Nickel ¹	66180-1	66181-1
Solder Tab		Duplex ²	202236-1	202237-1
		Bright Tin-Lead ³	202236-2	202237-2

¹0.00030 [0.00076] gold in mating area over .000050 [0.00127] nickel.

²Duplex plated .000030 [0.00076] gold in mating area over .000050 [0.00127] nickel on contact body; bright tin-lead on solder tab.

³Bright tin-lead on entire contact.

Note: These contacts can be used in Multimate contact cavities of all connector housings.

‡Single contact, free-air test current is not to be construed as contact rating current. Use only for testing.

Refer to contact current carrying capability information on page 3.

Extraction Tool **Part No. 305183** (Instruction Sheet 408-1216)

Signal Contacts (Continued)

Type III+, Posted
(Replacement Contacts,
See Note Below)



Pin



Socket

Material

Contact Body and Post—Brass

Retention Spring—Stainless steel

Finish

See chart.

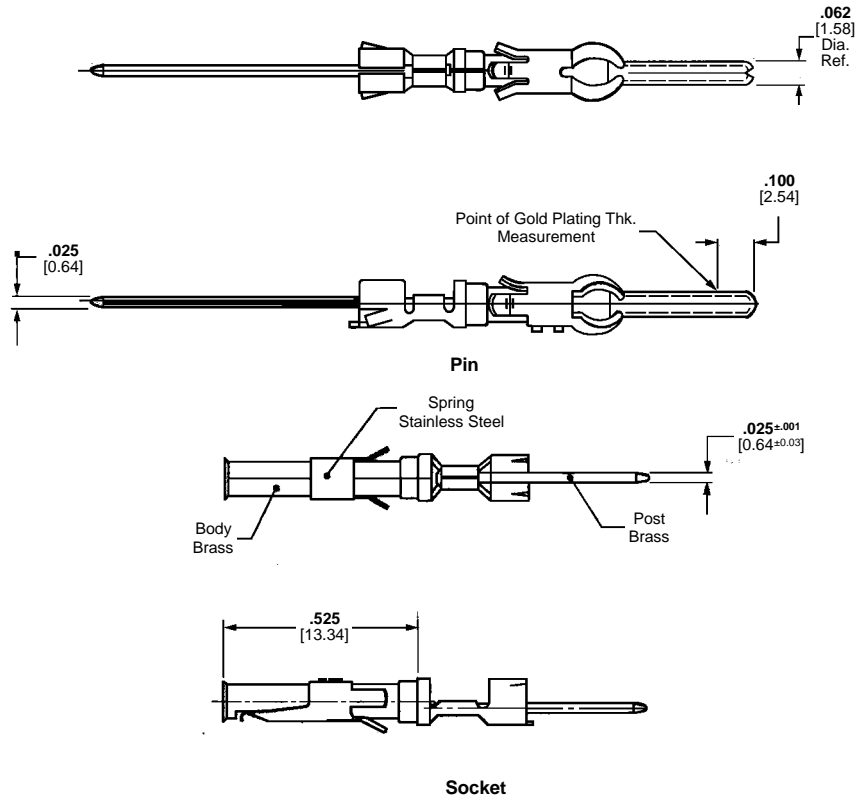

Contact Size 16—Pin Diameter .062 [1.57] (Test Current, 13 Ampere)‡

Termination Method	Post Configuration	Contact Finish	Loose Piece Contact No.					
			3 Termination High Post		2 Termination High Post		1 Termination High Post	
			Pin	Socket	Pin	Socket	Pin	Socket
Wrap-Type	.025 x .025 0.64 x 0.64	Sel. Gold/Nickel ¹	66460-9	66461-9	66460-8	66461-8	66460-7	66461-7
		Gold/Nickel ²	66460-6	66461-6	—	66461-5	66460-4	66461-4
		Bright Tin-Lead	66460-3	66461-3	66460-2	66461-2	66460-1	66461-1
	.045 x .045 1.14 x 1.14	Sel. Gold/Nickel ¹	66471-9	66473-9	—	—	66471-7	66473-7
		Bright Tin-Lead	66471-3	66473-3	—	—	66471-1	66473-1
		Sel. Gold/Nickel ¹	66470-9	—	—	—	66470-7	—
TERMI-POINT Clip	.031 x .062 0.79 x 1.57	Sel. Gold/Nickel ¹	66468-9	66459-9	—	—	—	—

¹Gold flash over .000050 [0.00127] nickel on entire contact, with .000030 [0.00076] gold to a distance of .200 [5.08] from mating end. Gold thickness controlled on socket O.D.

².000030 [0.00076] gold over .000050 [0.00127] nickel on contact body. Gold thickness controlled on socket O.D.

Posts plated tin-lead over copper.

Extraction Tool **Part No. 305183** (Instruction Sheet 408-1216)

Insertion Tool **Part No. 200893-2**

Note: These contacts are used as replacement contacts for all posted connectors.

‡Single contact, free-air test current is not to be construed as contact rating current. Use only for testing. Refer to contact current carrying capability information on page 3.

Signal Contacts (Continued)

Type II, Screw Machined, Crimp, Snap-In

Material

Contact Body—Brass

Retention Spring—Stainless steel

Finish

Contact Body—000030 [0.00076] gold over .000050 [0.00127] nickel. Gold thickness controlled on socket O.D.



Pin

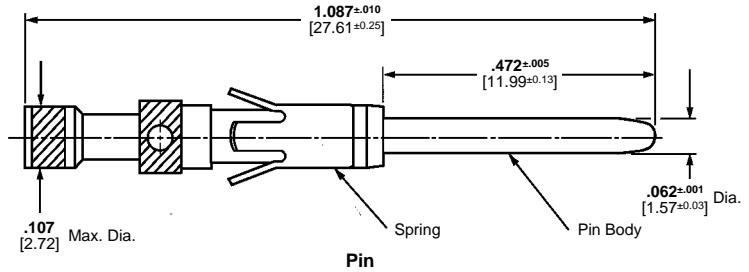

Related Product Data

Application Tooling—Pages 29, 30

Technical Documents

108-10039 Product Specification
114-10026 Application Specification



Socket

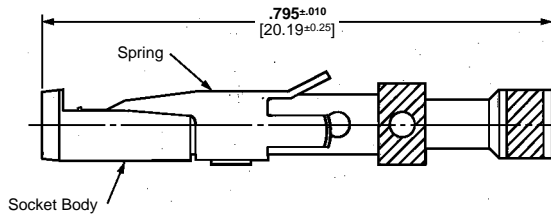

Socket

Contact Size 16—Pin Diameter .062 [1.57] (Test Current, 13 Ampere)‡

Wire Size Range		Ins. Dia. Range ¹	Tape Mounted Contact No. ²		Loose Piece Contact No.		Contact Color Code	Tooling Part No.		
			Pin	Socket	Pin	Socket		Tape Mounted Dies for AMP-TAPETRONIC Machine 69875	Loose Piece Die Set for 626 Pneumatic Tool System	Hand Tool
28-24	0.08-0.20	.035-.055 0.89-1.40	201611-4	—	201611-1 ⁴	201613-1 ⁵	Red/Red	—	90230-1 ⁷	91538-1 or 601967-1
		.048-.065 1.22-1.65	—	—	201334-1 ⁴	201332-1 ⁵	Red/Red	90249-2	—	—
		.095-.110 2.41-2.79	—	—	202410-1 ⁴	202411-1 ⁵	Green	—	—	601967-1
24-20	0.2-0.6	.040-.062 1.02-1.57	201578-4	—	201578-1 ⁴	201580-1 ⁵	Yellow/Red	—	90230-1 ⁷	91538-1 or 58541-1*
		.055-.088 1.40-2.16	201330-6	201328-9	201330-1 ⁴	201328-1 ⁵	Yellow/Red	90249-2	90230-1 ⁷	or 601967-1
18 (Two)	0.9-0.9 (Two)	No. Ins. Support	—	—	202725-1 ⁴	202726-1 ⁴	Blue	—	90231-2 ⁷	91539-1 or 601967-1
18-16	0.8-1.4	.080-.105 2.03-2.67	—	—	202507-1 ⁴	202508-1 ⁵	—	—	—	90136-1 or 601967-1
		No Ins. Support	200336-6	200333-8	200336-1 ⁴	200333-1 ⁴	Blue/Blue	90250-1	90231-2 ⁷	91539-1 58541-1* or 601967-1
14	2	No Ins. Support	212618-2 ³	201568-3	201570-1 ⁴	201568-1 ⁵	Violet/Blue	90250-1	90231-2 ⁷	91539-1 58541-1* or 601967-1
			201570-2	—	212618-13 ^{6,†}	—	Violet/Blue	90250-1	—	—

¹Overall insulation crimp diameter, including crimp barrel, must not exceed .125 [3.18].

²For AMP-TAPETRONIC Machine No. 69875, order contacts by Tape Mounted Contact No., plus packaging code "IM REEL" (5000 parts per reel).

³Grounding pin is used to provide a make-first/break-last condition when mating and unmating connector halves.

⁴Use turret TH502 (1-601967-6) with hand tool 601967-1.

⁵Use turret TH501 (1-601967-5) with hand tool 601967-1.

⁶Pin length is .630±.005 [16.002±.127] on these two pins.

⁷Die Set requires "C" Head Adapter Part No. 318161-1; Adapter Holder Part No. 356304-1 (with ratchet) or 189928-1 (without); and Power Unit Part No. 189721-2 (hand actuated) or 189722-2 (foot actuated).

*Commercial PRO-CRIMPER II Hand Tool for field repair use only. Note: Die Set can be adapted for use with the 626 Pneumatic Tool System.

†Does not use Hand Tool 45098 or 601967-1.

‡Single contact, free-air test current is not to be construed as contact rating current. Use only for testing. Refer to contact current carrying capability information on page 3.

Insertion Tool Part No. 200893-2 (for insulation diameters .070 [1.78] or less).

Extraction Tool Part No. 305183.

Signal Contacts (Continued)

Size 20 DF, Crimp, Snap-In

Contact Size—20

Pin Diameter—.040 [1.02]

***Test Current**—7.5 ampere

(Single contact, free-air test current; not to be construed as contact rating current. Use only for testing.)



Pin



Socket

Material

Pin Body—Brass

Socket—Phosphor bronze

Contact Finish

A—Select gold flash over nickel on entire contact, with additional .000030 [0.00076] gold on mating end

B—Duplex plated .000030 [0.00076] gold on mating end, tin-lead on termination end, with entire contact nickel underplated

C—Gold flash over nickel on entire contact

D—Duplex plated gold flash on mating end, tin-lead on termination end, with entire contact nickel underplated

***Note:** Total current capacity of each contact in any given connector is dependent on the heat rise resulting from the combination of electrical loads of all contacts in the connector arrangement and the maximum ambient temperature in which the connector will be operating. See page 3.

Insertion/Extraction Tool **Part No. 91285-1**

Instruction Sheet—408-9404

This tool includes interchangeable tips to Insert/Extract:

Size 22, 28-22 AWG [0.08-0.03mm²] Crimp Contacts

Size 20, 28-20 AWG [0.08-0.6mm²] Crimp and Solder Cup Contacts

Size 20, Posted Contacts

With Insulation Support

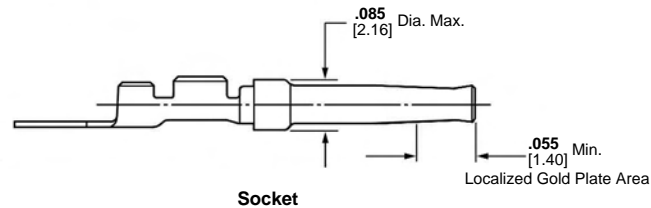
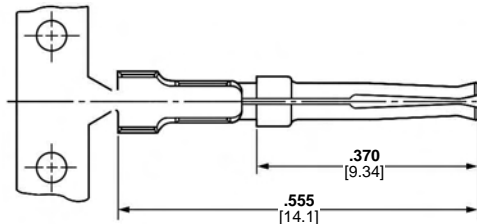
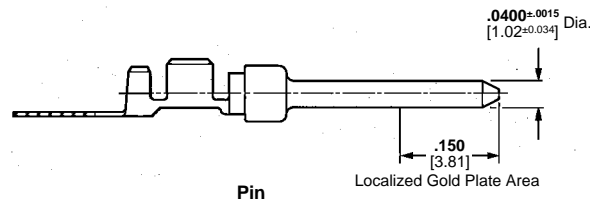
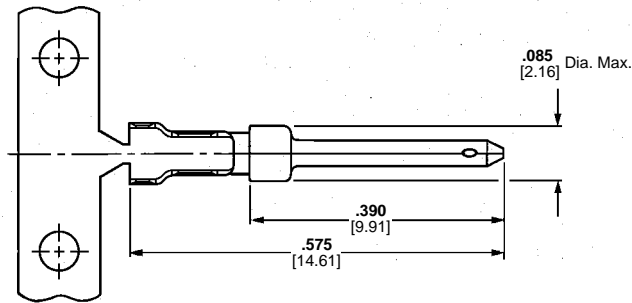

Wire Size Range	Ins. Dia. Max.	Contact Finish Code	Contact Part Nos.				Tooling		Color Code (Loose Piece)
			Pin		Socket		Strip Form Applicator††	Hand Tool	
			Strip Form	Loose Piece	Strip Form	Loose Piece			
28-24 AWG [0.08-0.2 mm ²]	.040 1.02	A	66507-3	66507-9	66505-3	66505-9	466423-□†† or 466901-1†† or 1016015-1††	91503-1†	Blue Dot
		B	3-66507-0	5-66507-7	6-66505-0	—			
		C	66507-4	1-66507-0	66505-4	1-66505-0			
		D	3-66507-1	5-66507-9	5-66505-7	5-66505-9			
26-22 AWG [0.12-0.4 mm ²]	.060 1.52	A	66682-2	66682-4	66683-2	66683-4	466758-2†† or 466963-1†† or 567804-1††	91549-1†	Black Dot
		B	66682-9	—	1-66683-0	—			
		C	66682-6	—	66683-7	—			
		D	745254-2	745254-6	745253-2	745253-6			
24-20 AWG [0.2-0.6 mm ²]	.050 1.27	A	1-745254-4	1-745254-6	1-745253-4	1-745253-6	466968-1†† or 567036-□†† or 567849-1††	91525-1†	Yellow Dot
		B	745254-3	745254-7	745253-3	745253-7			
		C	1-745254-1	1-745254-3	1-745253-1	—			
		D	66506-3	66506-9	66504-3	66504-9			
24-20 AWG [0.2-0.6 mm ²]	.060 1.52	A	2-66506-4	5-66506-7	5-66504-9	6-66504-0	466422-□†† or 466900-1†† or 567801-1†† or 1016002-1††	91503-1†	Red Dot
		B	66506-4	1-66506-0	66504-4	1-66504-0			
		C	2-66506-5	5-66506-9	5-66504-6	5-66504-7			
		D	—	—	—	—			

†To use with the 626 Pneumatic Tool System: remove the crimping head from the Straight Action Hand Tool (SAHT) Assembly, order SAHT Adapter **Part No. (Call Technical Support at 800-522-6752)**, Adapter Holder **Part No. 356304-1** (with ratchet) or **189928-1** (without), and Power Unit **Part No. 189721-1** (hand actuated) or **189722-1** (foot actuated).

††For complete information on AMP Strip Form Applicators for fully automatic and semiautomatic machines, contact Technical Support: 1-800-522-6752.

Note: Commercial PRO-CRIMPER II Maintenance and Repair Hand Tool for Wire Size 28-24 AWG [0.08-0.2mm²]

(Ins. Dia. Max. .040 [1.02]), and Wire Size 24-20 AWG [0.2-0.6mm²] (Ins. Dia. Max. .060 [1.52])—**Part No. 58448-2**.

Note: Die Set **Part No. 58448-3** can be adapted for use with the 626 Pneumatic Tool System.

Signal Contacts (Continued)

Size 20 DF, Crimp, Snap-In (Continued)



Pin



Socket

Without Insulation Support

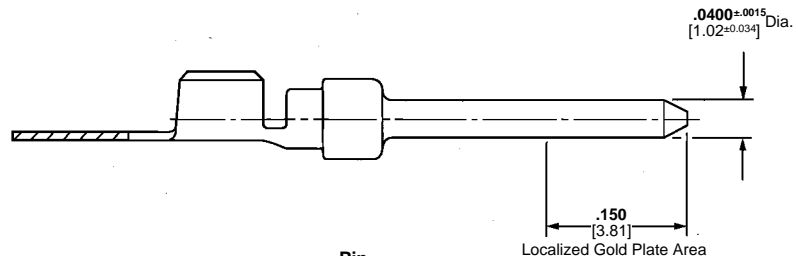
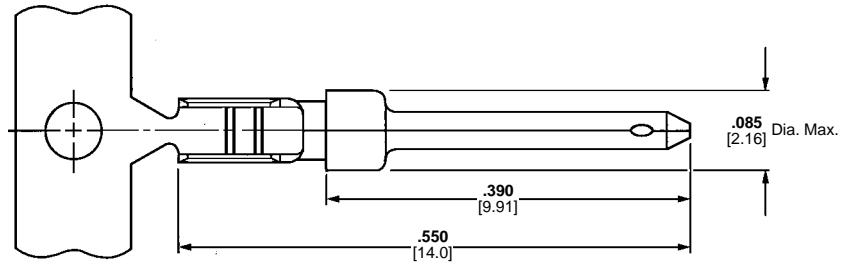

Pin

Localized Gold Plate Area

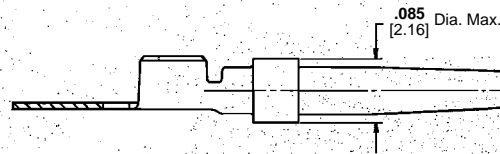
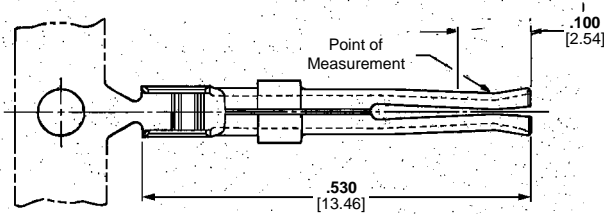

Socket

Wire Size Range	Ins. Dia. Max.	Contact Finish Code	Contact Part Nos.				Tooling		Color Code (Loose Piece)
			Pin		Socket		Strip Form Applicator	Hand Tool	
			Strip Form	Loose Piece	Strip Form	Loose Piece			
28-24 AWG [0.08-0.2 mm ²]	.068 1.73	A	205310-2	—	205311-3	—	††	91548-1	Blue Dot
		C	—	—	205311-4	—			
24-20 AWG [0.2-0.6 mm ²]	.068 1.73	A	205202-2	—	205201-3	205201-5	††	91548-1	Red Dot
		C	205202-6	205202-7	205201-6	205201-7			
22-18 AWG [0.4-0.8 mm ²]	.068 1.73	A	745229-2	745229-4	745230-2	745230-4	††	91513-1	Green Dot
		B	1-745229-1	—	1-745230-1	1-745230-3			
		C	745229-5	745229-7	745230-5	745230-7			
		D	—	—	745230-8	—			

††For complete information on AMP Strip Form Applicators for fully automatic and semiautomatic machines, contact Technical Support: 1-800-522-6752.

Note: Wire insulation diameter is limited by the connector housing cavity and clearance for the insertion/extraction tool.

Signal Contacts (Continued)

Size 20 DF, Solder, Snap-In

Contact Size—20

***Test Current**—7.5 ampere
(Single contact, free-air test current; not to be construed as contact rating current. Use only for testing.)



Pin



Socket

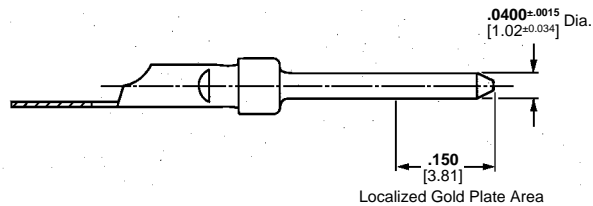
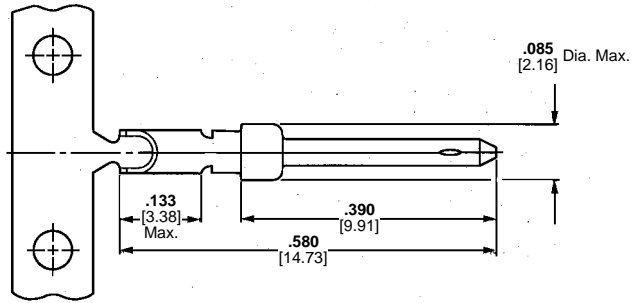

Pin

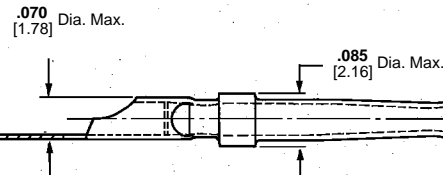
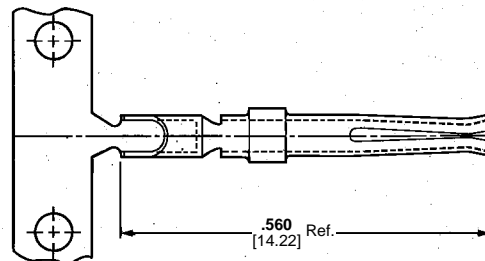

Socket

Material

Pin—Brass

Socket—Phosphor bronze

Contact Finish

Gold flash over nickel on entire contact, with additional .000030 [0.00076] gold on mating end

Note: Total current capacity of each contact in a given connector is dependent on the heat rise resulting from the combination of electrical loads of all contacts in the connector arrangement and the maximum ambient temperature in which the connector will be operating. See page 3.

Contacts to be soldered to wire before being inserted into housing. 18 AWG [0.8-0.9 mm²] Max. Wire

Strip Form Contact No.		Loose Piece Contact No.	
Pin	Socket	Pin	Socket
66570-2	66569-2	66570-3	66569-3

Power Contacts

Type I, Crimp, Snap-In



Pin



Socket

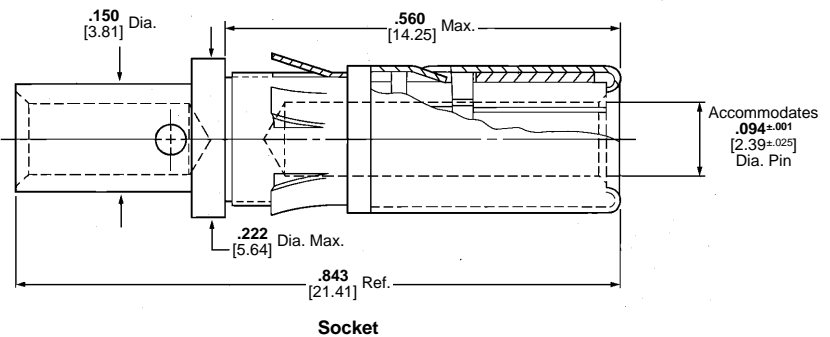
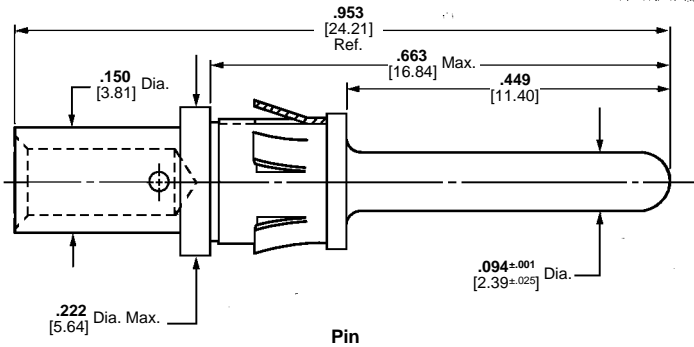

Material

Contact Body—Bronze
Retention Spring—Beryllium copper

Finish

Contact Body—.000030 [0.00076] gold over .000050 [0.00127] nickel. Gold thickness controlled on socket O.D.
Retention Spring—Nickel plated

Related Product Data

Application Tooling—Pages 29, 30

Technical Documents

108-10108 Product Specification
114-10037 Application Specification

Size 12—Pin Diameter .094 [2.39] (Test Current, 23 Ampere)‡

Wire Size Range		Loose Piece Contact No.		Tooling Part No.	
AWG	[mm ²]	Pin	Socket	Dies for Pneumatic Tool*	Hand Tool
18-16	0.8-1.4	202421-1	202418-1	90122	90121
14-12	2-3	202422-1	202417-1	90122	90121

*Use hand actuated Power Unit **Part No. 189721-2** or foot actuated Power Unit **Part No. 189722-2**. Both units require "C" Head Die Set Adapter **Part No. 318161-1** and an Adapter Holder **Part No. 356304-1** (with ratchet) or **Part No. 189928-1** (without ratchet). Request Catalog 124208 for more information on the 626 Pneumatic Tool System.

‡Single contact, free-air test current; not to be construed as contact rating current. Use only for testing. Refer to contact current carrying capability information, page 3.

Extraction Tool **Part No. 305183-8** (Instruction Sheet 408-1216)

Power Contacts—High Current Upgrade (Continued)

Type II and Type III+, Size 16

The features of the High Current Size 16 contact have been designed to fit into the existing AMP Multimate Connectors such as CPC (Circular Plastic Connector), CMC (Circular Metal Connector), G Series, M Series, Econoseal Metrimate Square Grid and Drawer Connector housings. An initial T-Rise test in free air has shown a 23 amp capability with a 30°C T-Rise. The contact may be crimped onto 14 AWG wire with a Tyco Electronics hand tool P/N 601967-1. Use turret TH502 (1-601967-6) for the pin and turret TH501 (1-601967-5) for the socket.

Wire Size AWG	High Current Size 16 Socket Part No.	
	Loose Piece	Tape
14	193846-1	193846-2
18-16	796966-1	796966-2

Wire Size AWG	High Current Size 16 Pin Part No.	
	Loose Piece	Tape
14	193844-1	193844-2
18-16	796964-1	796964-2

High Current Size 16 Pin (Board Mount) Part No. 194264-1

Material

Pin Body — Leaded Brass; Copper Alloy (Board Mount)

Socket Body — Copper Alloy

Louvertac Band — Beryllium Copper

Retention Spring — Stainless Steel

Finish

Body — Silver

Louvertac Band — Gold



Extraction Tool Part No. 305183



4 Pos. CPC Posted Square Flange Receptacle Part No. 796764-1
Mates with CPC Plug (Part No. 206060-1) with either Type II or High Current Socket contact

Current-Carrying Capacity. The graph shows current-carrying capacity versus temperature rise for a fully energized 6 position Metrimate Square Grid plug P/N 207152-1 and receptacle P/N 207153-1. These initial representative amperage ratings were conducted with 14 AWG wires that were 2 feet long.

Current Rating for 30°C Temperature Rise 100% Energized
6 Circuit Metrimate Connector (Wire-to-Wire)

TEMPERATURE RISE VS. CURRENT

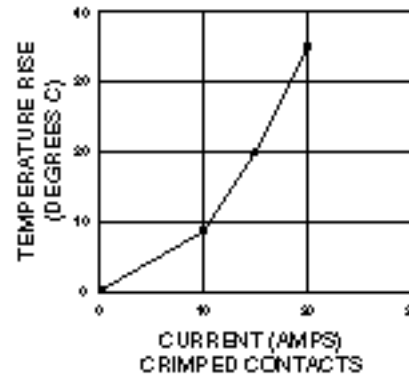

■ **Recognized under the Component Program of Underwriters Laboratories Inc., File No. E28476**

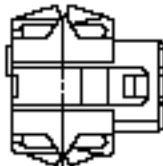
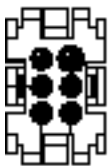

Plug (for Sockets)

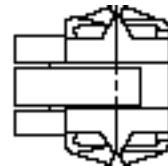
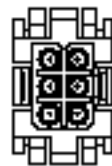

Receptacle (for Pins)

- Notes:**
1. High Current contacts with Louvertac bands are NOT intermateable with any other contact.
 2. Additional information on CPC and CMC connectors is available in Catalog 82021.
 3. Additional information on G Series connectors is available in Catalog 82046.
 4. Additional information on M Series connectors is available in Catalog 82003.
 5. Additional information on Metrimate connectors is available in Catalog 82045.
 6. Additional information on Econoseal connectors is available in Catalog 82057.
 7. Additional information on LGH connectors is available in Catalog 82024.

Power Contacts—High Current Upgrade (Continued)

Size 20, Posted

The High Current Size 20 contact has been designed to fit into the Series 109 AMPLIMITE Connectors per MIL-C-24308.

Material

Body — Copper alloy

Louvertac Band — Beryllium copper

Finish

Body — Gold

Louvertac Band — Gold

Current-Carrying Capacity. The High Current Size 20 contact with a 20 gage wire attached to the .030 diameter solder tail acquired an initial 30° T-Rise of **11.85 amps** in free air.

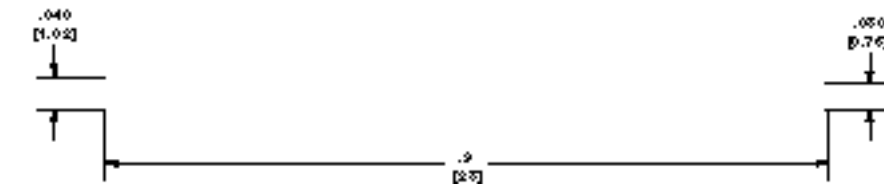
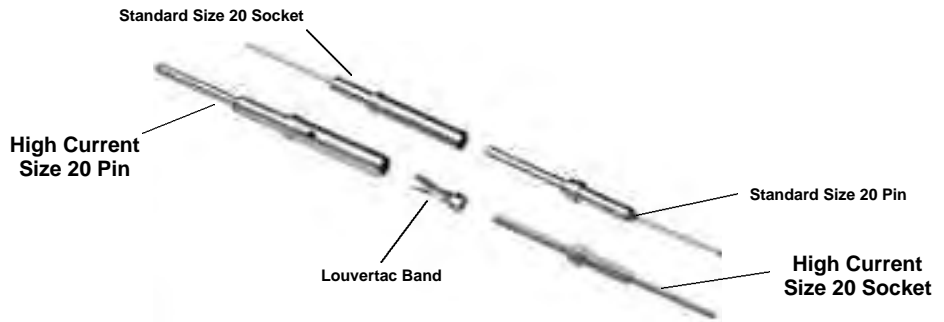

Pin Part No. 194081-1



Socket Part No. 194083-1

The contacts can be sold loose piece or installed into any of the MIL Standard connectors.



Pin and Socket Insertion/Extraction Tool

Part Number **91067-2** or MIL number **M81969/1-02**

Insertion tip, for replacement Part Number **126195-3**

Extraction tip, for replacement Part Number **126195-4**

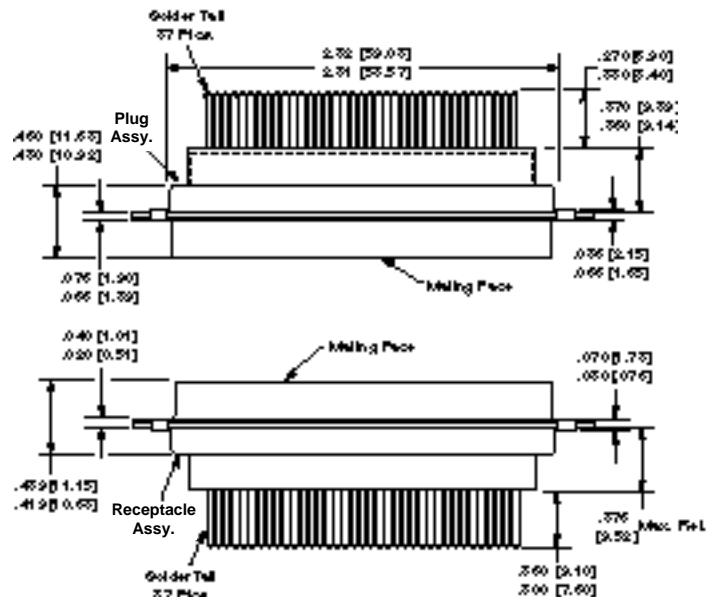

Typical Fully Loaded 37 Position Plug and Receptacle

- Notes:** 1. High Current contacts with Louvertac bands are **not** interchangeable with any other contact.
2. Additional information on connectors is available in Catalog No. 82069.

Power Contacts (Continued)

.125 POWERBAND Contacts

Pin Diameter — .125 [3.175]

Test Current — 50 Amperes‡

Material and Finish

Contact — Copper

Spring — Beryllium copper

Plating Code

A. 0.00508 [.000200] min. silver on contact area, 0.00127 [.000050] min. on remainder, all over 0.00127 [.000050] min. nickel underplate

B. 0.00076 [.000030] min. gold on contact area, gold flash on remainder, all over 0.00127 [.000050] min. nickel underplate

Related Product Data

Application Tooling — Pages 29, 30

Technical Document — Page 4

Extraction Tool

Part No. 318813-1

(Instruction Sheet 408-4374)

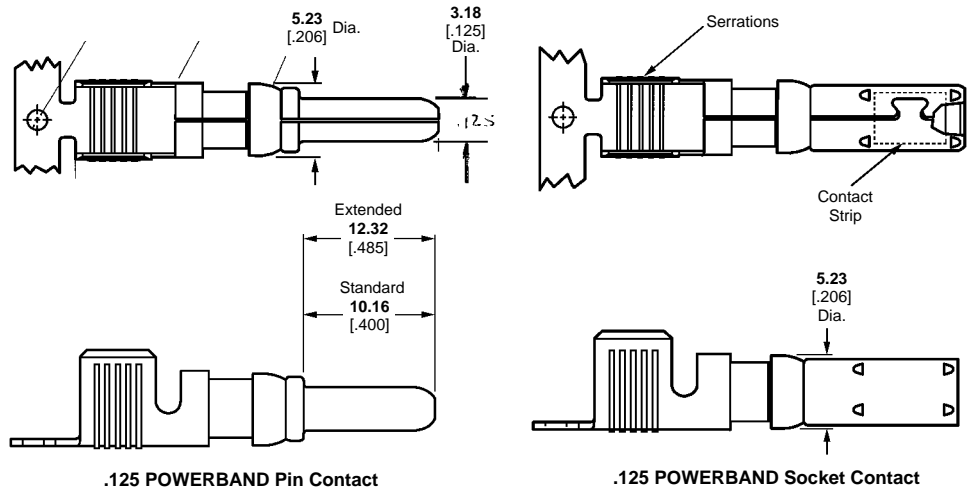

Wire Size AWG/mm ²	Contact Finish	Pin Length	Contact Part No.				Tooling Part No.	
			Strip		Loose Piece		Heavy Duty Miniature (HDM) Applicators (for AMP-O-LETRIC Model G Machine, Base Part No. 354500)	Die Sets for Hand Tool 69710-1 or 626 Pneumatic Tool System*
			Pin	Socket	Pin	Socket		
14-12 2-3	A	Standard	213845-1	213847-1	213845-3	213847-3	680195-3	356612-1
	B	Standard	213845-2	213847-2	213845-4	213847-4		
	A	Extended ¹	213845-5	—	213845-7	—		
	B	Extended ¹	213845-6	—	213845-8	—		
10-8 5-8	A	Standard	213841-1	213843-1	213841-3	213843-3	680197-3	356611-1 (8 AWG) 356611-2 (10 AWG)
	B	Standard	213841-2	213843-2	213841-4	213843-4		
	A	Extended ¹	213841-5	—	213841-7	—		
	B	Extended ¹	213841-6	—	213841-8	—		

¹For use in Metrimate Drawer Connectors listed in chart below and Two-Piece Sealed Circular Plastic Connectors (CPC), Series 5 and 6.

‡Single contact, free-air test current; not to be construed as contact rating current. Use only for testing.

Refer to contact current carrying capability information, page 3.

Note: Standard Size 8, High Current Size 8 upgrade, and .125 POWERBAND contacts are **not** interchangeable.

*A typical 626 Pneumatic Tool System requires: a power unit (**Part No. 189721-2**, hand actuated or **189722-2**, foot actuated), an adapter holder (**Part No. 356304-1**, with ratchet), and "C" Head adapter **Part No. 318161-1**.

.125 POWERBAND Metrimate Drawer Connectors

No. of Pos.	Housing Part No.	
	Plug	Receptacle
8	213886-1**	213500-3**

Color: blue

**For use with .125 POWERBAND contacts (Extended Pin Length), listed above.

Power Contacts (Continued)

Standard, Size 8, 4/8 Indent Crimp



Pin



Socket

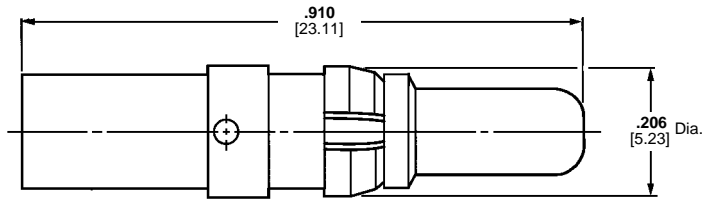

Pin

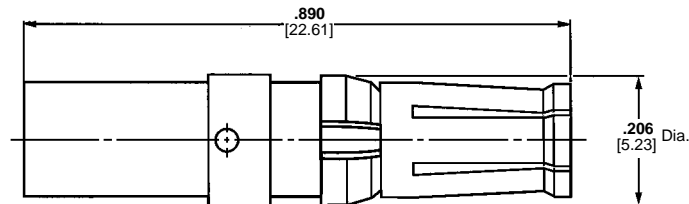

Socket

Note: Standard Size 8, High Current Upgrade Size 8 and .125 POWERBAND contacts are **not** intermateable.

Material

Contact Body—Copper alloy
Retention Clip—Phosphor bronze

Finish

Contact Body—.000050 [0.00127] gold over .000050 [0.00127] nickel
Retention Spring—Nickel plated

Related Product Data

Technical Documents
108-10045 Product Specification
114-10014 Application Specification

Power Contacts, Standard, Size 8 (Test Current 50 Amperes)‡

Wire Range		Contacts		Crimping Tools	
AWG	[mm ²]	Pin	Socket	Tool No.	Positioner
18-16	0.8-1.4	213567-1	212014-1	608668-1	(P) SP867 (S) 608668-2
14-12	2-3	213662-1	212008-1	608651-1	(P) SP867 (S) 608651-2
10	5	213740-1	213737-1	608651-1	(P) 608651-3 (S) 608651-2
8	8	213552-2	213750-1	608651-1	(P) 608651-3 (S) 608651-2

‡Single contact, free-air test current; not to be construed as contact rating current. Use only for testing. Refer to contact current carrying capability information, page 3.

Power Contacts—High Current Upgrade (Continued)

Metrimate Drawer Connector, Size 8

The Louvertac bands have the versatility of being designed into contact dimensions used in existing Tyco Electronics connectors.

Metrimate High Current contacts have been designed to fit into the existing Drawer Connector housings. A fully energized 8 position connector with 8 gage wires can handle 30 amps per line with a 30°C T-rise on either the cable-to-cable or cable-to-board.

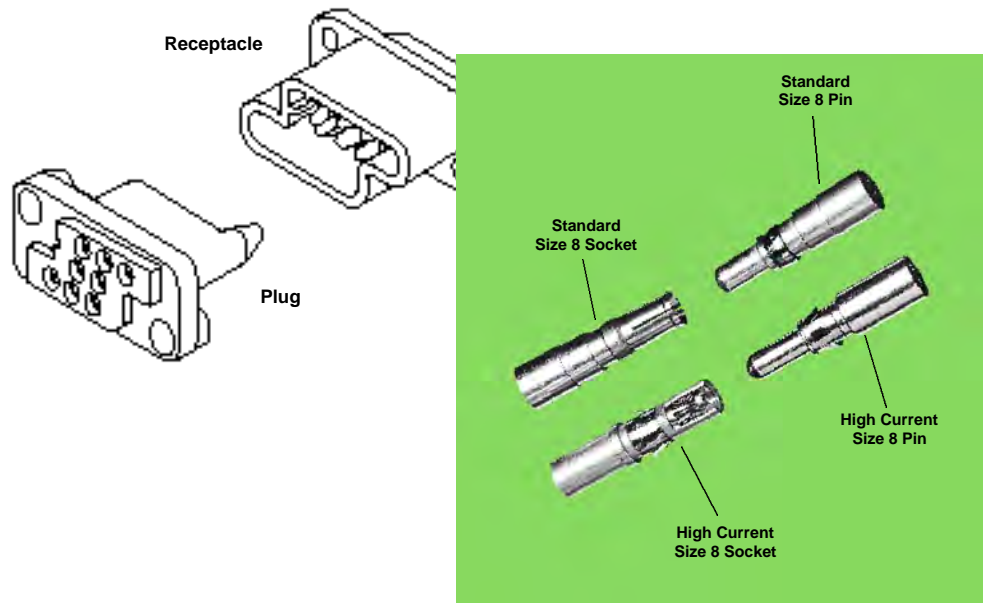

Cable-to-Cable

Material

- Contact Body** — Copper Alloys
- Louvertac Band** — Beryllium Copper
- Retention Spring** — Stainless Steel
- Finish** — Gold

Product Specification

108-1449 Metrimate Pin and Socket with Louvertac High Current Contact

Connector Voltage Rating — 600 VAC

■ **Recognized under the Component Program of Underwriters Laboratories Inc., File No. E28476**



■ **Certified by Canadian Standards Association, File No. LR7189A**



High Current Contacts

Wire Size AWG	Contact Part Numbers		Crimp Tools
	Pin	Socket	
8	193457-1	193458-1	Daniels† Hand Tool #M310 or AMP P/N 356114-1 Positioner #TP944 or AMP P/N 356336-1
10	193642-1	193643-1	
12-14	193534-1	193535-1	

Extraction Tool Part No. 318813-1 or 305183-6

†Daniels Manufacturing Corp., Orlando, FL

Cable-to-Board

Material

- Contact Body** — Copper Alloys
- Louvertac Band** — Beryllium Copper
- Retention Spring** — Stainless Steel
- Finish** — Gold

A typical application would have solder tail pins mounted into the receptacle and crimp sockets mounted into the plug.

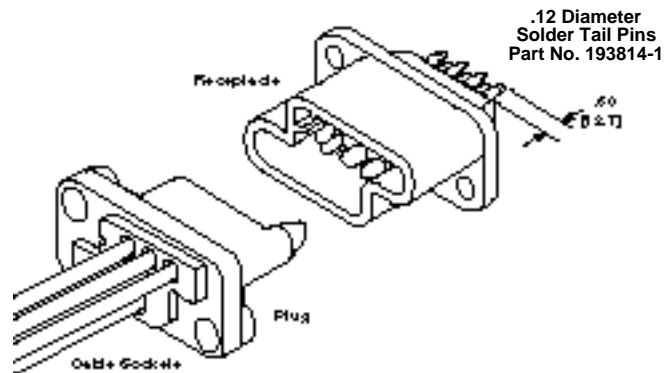

Drawer Connector Housings

Size Configuration	Housing Part Numbers	
	Plug	Receptacle
8 Positions (8 Size 8 Cavities)	213499-1	213500-1
15 Positions (3 Size 8 Cavities & 12 Size 16 Cavities)	213426-1	213427-1

Extraction Tool Part No. 318813-1

Notes: 1. High Current contacts with Louvertac bands are NOT intermateable with any other contact.
2. Additional information on connectors is available in Catalog 82045.

Power Contacts (Continued)

Type XII, Precision Formed, Crimp, Snap-In

Material

Copper

Finish

- A—Tin-lead
- B—.000030 [0.00076] selective gold over .000030 [0.00076] nickel
- C—.000100 [0.00254] silver plated contacts with lubricant added

Test Current Rating

Silver or Gold —35 amperes ‡

Tin Lead —15 amperes ‡

‡Single contact, free-air test current; not to be construed as contact rating current. Use only for testing. Refer to contact current carrying capability information, page 3.

Related Product Data

Application Tooling —Pages 29, 30

Technical Documents —Page 4



Male



Female

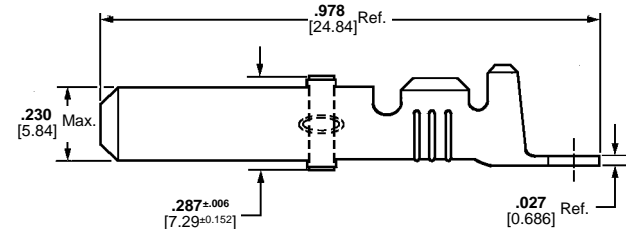
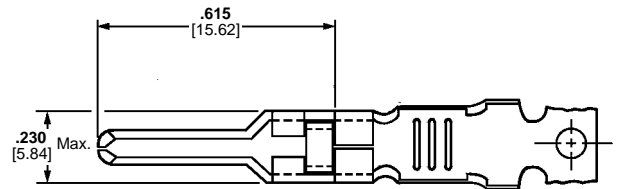

Male

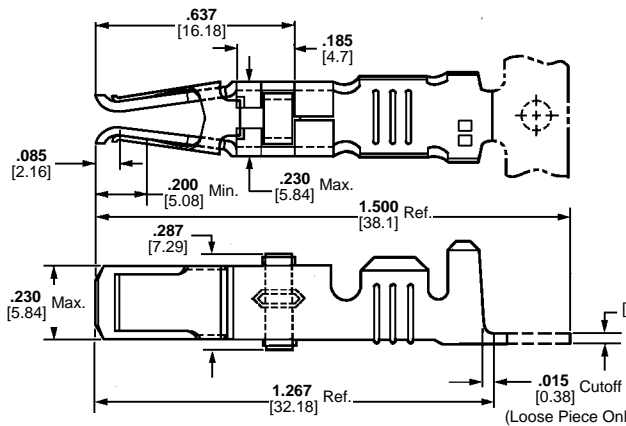

Female



Extraction Tool Part No. 91019-3

Wire Size Range ¹	Ins. Dia. Range	Contact Finish	Strip Form Contact Part Nos.				Loose Piece		Tooling		
			Standard***		Heavy Duty Miniature***		Contact Part Nos.		Heavy Duty Miniature Applicator	Die Set for Hand Tool 69710-1 or 626 Pneumatic Tool System	
AWG	mm ²		Male	Female	Male	Female	Male	Female			
16 and 14-12	1.25-1.4 and 2-3	.135-.160 3.43-4.06	A	66255-1	66740-7	66255-5	1-66740-2	66261-1	66740-8	567455-□***	90145-2 ^{3,7} and 90145-1 ^{4,7}
				66256-1 ²	—	66256-5 ²	—	66262-1 ²	—		
			B	66255-2	66740-5	66255-6	1-66740-1	66261-2	66740-6		
				66256-2 ²	—	66256-4 ²	—	66262-2 ²	—		
			C ⁵	66255-7	66740-1	66255-8	66740-9	66261-4	66740-2		
				66256-6 ²	—	66256-7 ²	—	66262-4 ²	—		
10	5-6	.190-.220 4.83-5.59	A	66253-1	66741-7	66253-5	1-66741-2	66259-1	66741-8	567021-□***	90140-1 ⁷
				66254-1 ²	—	—	—	66260-1 ²	—		
			B	66253-2	66741-5	66253-6	1-66741-1	66259-2	66741-6		
				66254-2 ²	—	—	—	66260-2 ²	—		
			C ⁵	66253-4	66741-1	66253-8	66741-9	66259-4	66741-2		
				66254-4 ²	—	—	—	66260-4 ²	—		

¹Wire strip length—.281 [7.14].

²Ground contact.

³Die insert PartNo. 90145-2 is for crimping 16 AWG [1.25-1.4 mm²] wire.

⁴Die insert PartNo. 90145-1 is for crimping 14-12 AWG [2-3 mm²] wire.

⁵Recommended for high current/vibration applications where fretting corrosion is a problem.

⁷Die Set requires "C" Head Adapter Part No. 318161-1; Adapter Holder Part No. 356304-1 (with ratchet) or 189928-1 (without); and Power Unit Part No. 189721-2 (hand actuated) or 189722-2 (foot actuated).

Extraction Tool Part No. 91019-3

***Call Technical Support at 1-800-522-6752 for Automatic Machine Applicator Part Numbers.

Power Contacts—High Current Upgrade (Continued)

Type XII, Screw Machined

The features of the High Current Type XII contact have been designed to fit into the existing AMP Multimate Connectors such as CPC (Circular Plastic Connector), CMC (Circular Metal Connector), G Series, and M Series housings. An initial T-Rise test in free air has shown a 60 amp capability with a 30°C T-Rise with 8 gage wires. The contact may be crimped onto 8 AWG wire with a Daniels Hand Tool M310 or AMP P/N 356114-1 and Positioner TP1068S or AMP P/N 356119-1.



* Not recommended for CPC connectors.

Cable-to-Cable

Material

Body — Copper Alloy

Louvertac Band — Beryllium Copper

Retention Spring — Stainless Steel

Finish

Body — Silver

Louvertac Band — Gold



Extraction Tool Part No. 224155-1

Current-Carrying Capacity. The graph shows current-carrying capacity versus temperature rise for a fully energized 3 position CPC plug P/N 206037-2 and receptacle P/N 206036-2. These initial representative amperage ratings were conducted with 8 AWG wires that were 3 feet long.

■ **Recognized under the Component Program of Underwriters Laboratories Inc.,**  **File No. E28476**

Current Rating for 30°C Temperature Rise 100% Energized

3 Circuit Connector (Wire-to-Wire)

TEMPERATURE RISE VS CURRENT

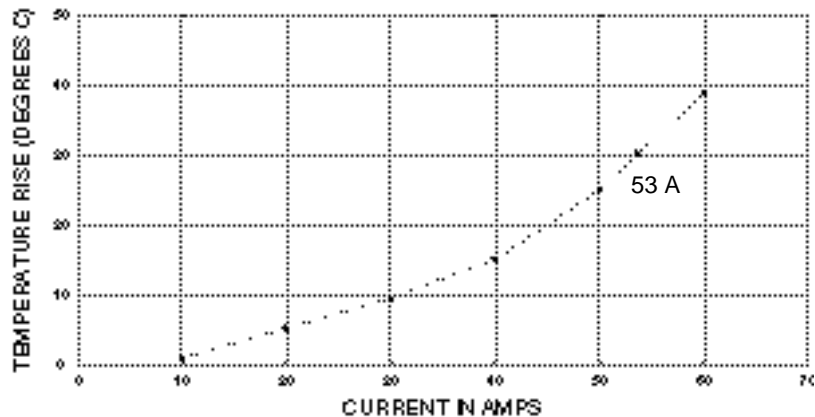

Plug
(For Sockets)



Square Flange Receptacle
(For Pins)

Notes: 1. High Current contacts with Louvertac bands are NOT intermateable with any other contact.

2. Additional information on CPC and CMC connectors is available in Catalog 82021.

3. Additional information on G Series connectors is available in Catalog 82046.

4. Additional information on M Series connectors is available in Catalog 82003.

5. Additional information on LGH connectors is available in Catalog 82024.

Coaxial Contacts

Subminiature, Crimp, Snap-In, Size 16



Pin



Socket

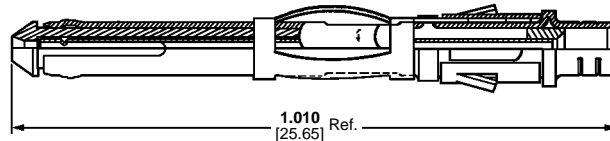

Pin

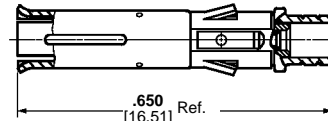

Socket

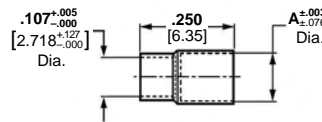

Ferrule

Part No. 225088-1 — A .120 [3.05] Dia.

225088-3 — A .123 [3.12] Dia.

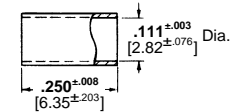

Ferrule
Part No. 1-332056-0

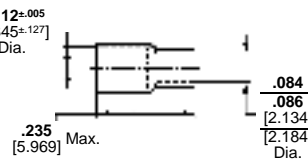

Ferrule
Part No. 1-332057-0

Selection Chart for Coaxial Cable

Cable Size (RG/U)	Contact Finish	Loose Piece Contact No.		Ferrule Part No.	Tooling Part No.	
		Pin	Socket		Die Inserts for Hand Tool 69710-1 or Pneumatic Tool*	Hand Tool
178, 196	Gold/Nickel Gold/Copper ¹	226537-2	51565-2	1-332057-0	69690-2	69656-2
	Gold/Nickel Gold/Copper ²	—	51565-5			
196 (Double Braid)	Gold/Nickel Gold/Copper ¹	226537-2	51565-2	225088-1	—	69656-9
	Gold/Nickel Gold/Copper ²	—	51565-5			
174, 188, 316	Gold/Nickel Gold/Copper ¹	226537-1	51565-1	1-332056-0	69690	91911-3**
	Gold/Nickel Gold/Copper ²	226537-4	51565-4			
174 (Double Braid)	Gold/Nickel Gold/Copper ¹	226537-1	51565-1	225088-3	—	69656-7
	Gold/Nickel Gold/Copper ²	226537-4	51565-4			
179, 187	Gold/Nickel Gold/Copper ¹	226537-1	51565-1	1-332056-0	69690-1	91911-4**
	Gold/Nickel Gold/Copper ²	226537-4	51565-4			
187 (Double Braid)	Gold/Nickel Gold/Copper ¹	226537-1	51565-1	225088-1	—	69656-8
	Gold/Nickel Gold/Copper ²	226537-4	51565-4			
161	Gold/Nickel Gold/Copper ¹	226537-1	51565-1	1-332056-0	—	69656-5
	Gold/Nickel Gold/Copper ²	226537-4	51565-4			

*Use hand actuated Power Unit **Part No. 189721-2** or foot actuated Power Unit **Part No. 189722-2**. Both units require "C" Head Die Set Adapter **Part No. 318161-1** and an Adapter Holder **Part No. 356304-1** (with ratchet) or **Part No. 189928-1** (without ratchet). Request Catalog 124208 for more information on the 626 Pneumatic Tool System.

**Die Set used with PRO-CRIMPER II hand tool frame Part No. 354940-1.

Extraction Tool **Part No. 305183**

Material

Outer Shell —Brass per MIL-C-50

Center Conductor —Beryllium copper per QQ-C-533 (Pin); Brass per QQ-B-626 (Socket)

Inner Dielectric —Polypropylene

Retention Spring —Stainless steel per QQ-S-766

Ferrule —Copper per QQ-C-576 or ASTM-B-152 (1-332056-0)

Finish

Outer Shell, Center Conductor — See charts

Ferrule —Tin-lead per MIL-T-10727

Dimensions are in inches and millimeters unless otherwise specified. Values in brackets are metric equivalents.

Dimensions are shown for reference purposes only. Specifications subject to change.

Technical Support
USA: 1-800-522-6752
Canada: 1-905-475-6222
Mexico: 01-800-733-8926

Central America: 52-55-5-729-0425
South America: 55-11-3611-1514
www.tycoelectronics.com

Subminiature, Crimp, Snap-In, Size 16
(Continued)

Coaxial Contacts (Continued)

Selection Chart for Twisted Pair and Shielded Wire

Wire Size		Contact Finish	Loose Piece Contact No.		Ferrule Part No.	Tooling Part No.	
AWG	[mm ²]		Pin	Socket		Die Inserts for Hand Tool 69710-1 or Pneumatic Tool*	Hand Tool
30	0.05	Gold/Nickel Gold/Copper ¹	226537-3	51565-3	1-332057-0	69690-2	69656-2
28	0.08-0.09	Gold/Nickel Gold/Copper ¹	226537-3	51565-3	1-332057-0	69690	91911-3**
28	0.08-0.09	Gold/Nickel Gold/Copper ¹	226537-3	51565-3	1-332057-0	69690-1 or 69690-2	91911-4** or 69656-2
26	0.12-0.15	Gold/Nickel ¹ Gold/Copper	226537-3	51565-3	1-332057-0	69690	91911-3**
26	0.12-0.15	Gold/Nickel Gold/Copper ¹	226537-1	51565-1	1-332057-0	69690-3	69656-3
		Gold/Nickel Gold/Copper ²	226537-4	51565-4			

¹.000030 [0.00076] gold over .000050 [0.00127] nickel—outer shell and socket center conductor; .000030 [0.00076] gold over .000100 [0.00254] copper—pin center conductor.

².000050 [0.00127] gold over .000050 [0.00127] nickel—outer shell and socket center conductor; .000050 [0.00127] gold over .000100 [0.00254] copper—pin center conductor.

*Use hand actuated Power Unit **Part No. 189721-2** or foot actuated Power Unit **Part No. 189722-2**. Both units require "C" Head Die Set Adapter **Part No. 318161-1** and an Adapter Holder **Part No. 356304-1** (with ratchet) or **Part No. 189928-1** (without ratchet). Request Catalog 124208 for more information on the 626 Pneumatic Tool System.

**Die Set used with PRO-CRIMPER II hand tool frame Part No. 354940-1.

Note: A ferrule is required for each pin and socket.

Extraction Tool Part No. 305183

Coaxial Contacts (Continued)

Miniature, Crimp, Snap-In, Size 12



Pin



Socket



Ferrule

Retention Spring
Part No. 201142-1

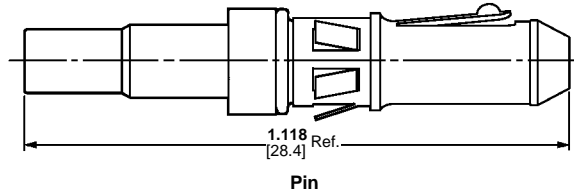
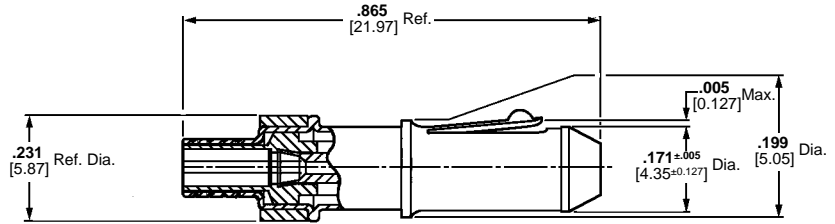

Pin

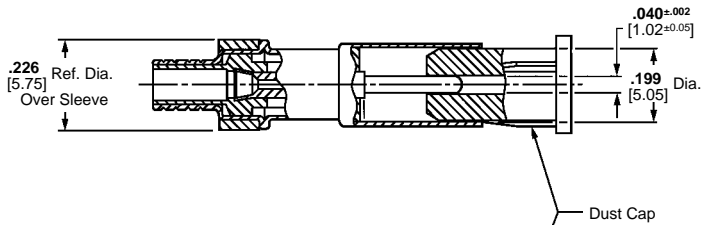

Dust Cap

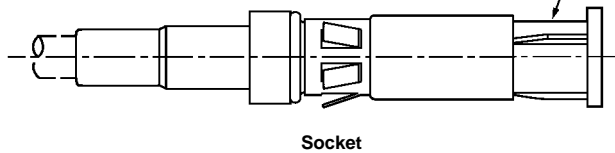

Socket

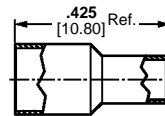

Ferrule

Material

Outer Shell —Brass per MIL-C-50

Center Conductor —Brass per QQ-B-626

Inner Dielectric —Polymethylpentene

Retention Spring —Beryllium copper per QQ-C-533

Ferrule —Copper per QQ-C-576

Finish

Outer Shell, Center Conductor — See charts on next page

Retention Spring —Nickel per QQ-N-290

Ferrule —Tin-lead per MIL-T-10727

Extraction Tool **Part No. 305183-8**

Coaxial Contacts (Continued)

**Miniature, Crimp, Snap-In,
Size 12**
(Continued)

Selection Chart for Coaxial Cable

Cable Size (RG/U)	Contact Finish	Loose Piece Contact No.		Ferrule Part No.	Tooling Part No.	
		Pin	Socket		Die Inserts for Hand Tool 69710-1 or Pneumatic Tool*	Hand Tool
58, 58A, 58B, 58C	Gold/Nickel ¹ Gold/Copper ²	201145-4 —	201146-4 201146-9	328663	69220-2	45740-2
174, 179A, 187, 21-598	Gold/Nickel ¹ Gold/Copper ²	201143-1 —	201144-1 201144-6	328666	69227-2	91912-3**
180, 180A, 195, 21-597	Gold/Nickel ¹ Gold/Copper ²	201145-2 1-201145-0	201146-2 1-201146-0	328664	69222-2	45639-2
178, 178A, 196	Gold/Nickel ¹	201511-1	201512-1	328667	69373	69186-2
188	Gold/Nickel ¹ Gold/Copper ²	201143-5 201143-7	201144-5 201144-7	328666	69227-2	91912-3**
122	Gold/Nickel ¹	201145-1	—	328664	69222-2	45639-2
188 Double Braid 316 Double Braid	Gold/Nickel ¹ Gold/Copper ²	201143-5 201143-7	201144-5 201144-7	221848-3	—	58290-1
Special .125, .100, .066, .012DB	Gold/Nickel ¹	201143-1	201144-1	221848-3	—	58290-1

Selection Chart for Twisted Pair

Wire Size AWG	[mm ²]	Max. Ins. Dia. (Two Wires Combined)	Contact Finish	Loose Piece Contact No.		Ferrule Part No.	Tooling Part No.	
				Pin	Socket		Die Inserts for Hand Tool 69710-1 or Pneumatic Tool*	Hand Tool
24-22 (Stranded)	0.2-0.4	.115 2.92	Gold/Nickel ¹ Gold/Copper ²	201143-5 201143-7	201144-5 201144-7	328666	69672	91912-3**
24-22 (Solid or Stranded)	0.2-0.4	.160 4.06	Gold/Nickel ¹	50079-1	50080-1	329029	69222-2	45639-2

Selection Chart for Shielded Wire

Shielded Wire AWG	No.	Contact Finish	Loose Piece Contact No.		Ferrule Part No.	Tooling Part No.	
			Pin	Socket		Die Inserts for Hand Tool 69710-1 or Pneumatic Tool*	Hand Tool
22	NAS-702, Class B	Gold/Nickel ¹ Gold/Copper ²	201145-4 —	201146-4 201146-9	328663	69220-2	45740-2

Selection Chart for Various Manufacturers' Cables

Cable Size AWG/Type	[mm ²]	Dielectric O.D. (Max.)	Cable O.D. Range	Braid	Contact Finish	Loose Piece Contact No.		Ferrule Part No.	Tooling Part No.	
						Pin	Socket		Die Inserts for Hand Tool 69710-1 or Pneumatic Tool*	Hand Tool
Brand Rex T5788A 26 AWG	0.12-0.15	.106 2.69	.160 4.06	Single	Gold/Nickel ¹ Gold/Copper ²	201145-2 1-201145-0	201146-2 1-201146-0	328664	69222-2	45639-2
Raychem 0030D1314 Army Ord. 11207177 32-26 AWG	0.03-0.15	.129 3.28	.122-.137 3.10-3.48	Single	Gold/Nickel ¹	—	201146-6	330587	—	69360-2

¹.000030 [0.00076] gold over .000030 [0.00076] nickel.
².000100 [0.00254] gold over .000100 [0.00254] copper.

*Use hand actuated Power Unit **Part No. 189721-2** or foot actuated Power Unit **Part No. 189722-2**. Both units require "C" Head Die Set Adapter **Part No. 318161-1** and an Adapter Holder **Part No. 356304-1** (with ratchet) or **Part No. 189928-1** (without ratchet). Request Catalog 124208 for more information on the 626 Pneumatic Tool System.

**Die Set used with PRO-CRIMPER II hand tool frame Part No. 354940-1.

Note: A ferrule and retention spring (**201142-2**) are required for each pin and socket.

Application Tooling



Crimp Quality Monitor (CQM)

This unique system provides 100% on-the-fly crimp inspection. It measures the crimp height of each termination, and evaluates the quality of each crimp. If a crimp is questionable, the monitor alerts the operator with both visual and audible alarms. It also provides ports for printing and networking. When used with AMP-O-LECTRIC Model "G" Termination Machines, the monitor is mounted to the machine. When used with AMPOMATOR CLS IV Lead-Making Machines, it is integrated into the machine's operating system.

For complete information, request Catalog 82275.



AMP-O-MATIC Stripper-Crimper Machine

Semiautomatic bench crimping machines that also strip the wire, and are therefore used for terminating jacketed cable. Feature manual precision adjustment of crimp height, keyed strip blades for faster, more accurate setups, and an efficient scrap removal system. All adjustments can be made from the front of the machines without special tools. Available with crimp quality monitoring.

For complete information, request Catalog 65004.

AMPOMATOR CLS IV+ Lead-Making Machine

Fully-automatic machines that measure, cut, strip and terminate single leads. Microprocessor-controlled, and programmed and operated using an easy-to-follow, menu-driven touch-screen. Features include direct-drive terminating units with precision crimp height adjustment, fully programmable setups, wire runout and splice detection, and motorized pre-feed with wire straightener. Crimp quality monitoring is also available.

For more information, request Catalog 124324.

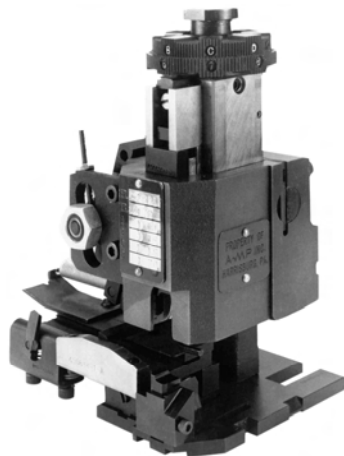

Quick-Change Applicators

These applicators can be changed in minutes to afford maximum flexibility and minimum production downtime for a wide range of AMP automatic machines. Crimp height for a given wire size is simply "dialed in."

For complete information, see specific AMP automatic machine catalog.

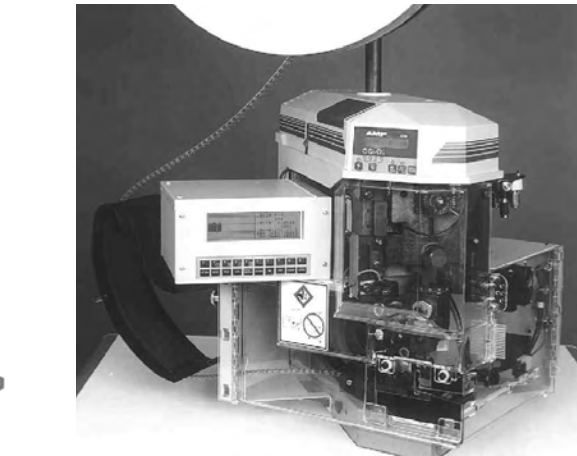

AMP-O-LECTRIC Model G Terminating Machine

Semiautomatic bench machines for crimping reeled terminals and contacts, featuring a quiet and reliable direct motor drive, microprocessor controls for ease of setup and operation, and guarding and lighting designed for operator convenience. All models are equipped with either

manual or automatic precision adjustment of crimp height. Machine-mounted sensors are available for crimp quality monitoring using conventional miniature-style applicators.

For complete information, request Catalog 65828.

Entry Level Terminator (ELT)

Semiautomatic bench terminator for side- and end-feed reeled terminals and contacts. The ELT uses a DC motor with gear box drive. The result is a small-footprint design that is fast and quiet. Cycle time is less than 0.400 seconds with an

operation sound level of 76 dBA. It has a crimp force capacity of 3,000 pounds. Optional equipment is also available to meet specific application requirements.

For complete information, request Catalog 1308382.

Application Tooling (Continued)



PRO-CRIMPER II Hand Tool Part No. 58495-1

Commercial grade hand tool for crimping various products. Features ratchet control to provide complete crimp cycle. Accepts both pinned- and shouldered-style die sets. Locators are provided with pinned-style die sets for proper contact and wire positioning, and to help minimize contact rotation and bending during crimping. Approximate weight 1.3 lb [0.60 kg].

For complete information, request Catalog 82276.

CERTI-CRIMP Hand Tools

These premium tools are ideal for small production, prototype and experimental applications. They are used for terminating pin and socket contacts to wire and feature the CERTI-CRIMP ratchet device to provide for properly formed crimps.



Straight Action Hand Tool

For Type III+ contacts, see page 9.



"C" Head Straight Action Hand Tool, Part No. 69710-1

For subminiature coaxial contacts, see pages 25 & 26.



626 Pneumatic Tool, Part No. 189721-2 (Power Unit ONLY)

For various contacts, see pages 9, 13-14, 17, 20, 23 & 25-28.

Tooling Numerical Index

Part No.	Page
45098	13
45639	28
45740	28
58290	28
58448	14
58495	9,10,30
58541	13
69186	28
69222	28
69227	28
69248	28
69315	28
69360	28
69373	28
69656	25,26
69672	28
69690	25,26
69710	20,23,25,26,28,30
69875	13
90121	17
90122	17
90136	13
90140	23
90145	23
90225	9
90230	13
90231	13
90249	13

Part No.	Page
90250	13
90716	9
91002	9
91019	23
91067	19
91285	14
91503	14
91505	9,10
91513	15
91515	9,10
91519	9
91521	9
91523	9,10
91525	14
91538	13
91539	13
91542	9
91548	15
91549	14
91911	25,26
91912	28
126195	19
189721	9,10,13,14,17,20,23,25,26,28,30
189928	9,10,13,14,17,23,25,26,28
200893	9,12,13
305183	9,11,12,13,17,18,22,25,26,27

Part No.	Page
318161	13,17,20,23,25,26,28
318813	20,22
354500	20
354940	25,26,28
356114	22,24
356119	24
356304	9,10,13,14,17,20,23,25,26,28
356336	22
356611	20
356612	20
466321	9
466323	9,10
466324	9
466325	9
466326	9
466383	9
466422	14
466423	14
466585	9
466598	9
466741	10
466758	14
466900	14
466901	14
466906	9
466907	9,10
466908	9

Part No.	Page
466923	9
466942	9
466958	9
466963	14
466968	14
466979	9
567021	23
567036	14
567363	9
567364	9
567455	23
567801	14
567804	14
567849	14
567867	9
567947	9
601967	13,18
608651	21
608668	21
680114	10
680195	20
680197	20
680602	9
725840	10
1016002	14
1016015	14
SP867	21

Part Number Index

Note: This numerical index lists all cataloged parts by base no. only. Complete part nos. (with prefixes and/or suffixes) are shown on the page(s) indicated.

Part No.	Page	Part No.	Page	Part No.	Page
50079	28	66566	9	202422	17
50080	28	66569	16	202507	13
51565	25,26	66570	16	202508	13
66098	9	66597	9	202725	13
66099	9	66598	9	202726	13
66100	9	66601	9	204219	13
66101	9	66602	9	205201	15
66102	9	66682	14	205202	15
66103	9	66683	14	205310	15
66104	9	66740	23	205311	15
66105	9	66741	23	206036	24
66106	9	164159	10	206037	24
66107	9	164160	10	206060	18
66108	9	164161	10	207152	18
66109	9	164162	10	207153	18
66180	11	164163	10	212008	21
66181	11	164164	10	212014	21
66182	11	193457	22	212618	13
66183	11	193458	22	213426	22
66253	23	193534	22	213427	22
66254	23	193535	22	213499	22
66255	23	193642	22	213500	20,22
66256	23	193643	22	213552	21
66259	23	193814	22	213567	21
66260	23	193844	18	213662	21
66261	23	193846	18	213737	21
66262	23	193990	24	213740	21
66331	9	193991	24	213750	21
66332	9	194081	19	213841	20
66358	9	194083	19	213843	20
66359	9	194264	18	213845	20
66360	9	200333	13	213847	20
66361	9	200336	13	213886	20
66393	9	201142	27,28	221848	28
66394	9	201143	28	224155	24
66399	9	201144	28	225088	25
66400	9	201145	28	226537	25,26
66405	9	201146	28	328663	28
66406	9	201328	13	328664	28
66424	9	201330	13	328666	28
66425	9	201332	13	328667	28
66428	9	201334	13	329029	28
66429	9	201511	28	330478	28
66459	12	201512	28	330587	28
66460	12	201568	13	332056	25
66461	12	201570	13	332057	25,26
66468	12	201578	13	745229	15
66470	12	201580	13	745230	15
66471	12	201611	13	745253	14
66473	12	201613	13	745254	14
66504	14	202236	11	788085	9
66505	14	202237	11	788088	9
66506	14	202410	13	796764	18
66507	14	202411	13	796964	18
66563	9	202417	17	796966	18
66564	9	202418	17		
66565	9	202421	17		

tyco

Electronics

TYCO ELECTRONICS CORPORATION

AMP

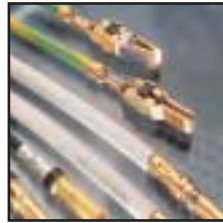
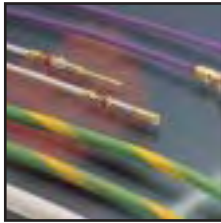

PRECISION PIN AND SOCKET CONTACTS