

mat'l code		tolerance unless otherwise specified		CUSTOMER		title	
rev. eon no.	dr. date	lineor	projection	copy	FCI		www.fciconnect.com
H V04-1160	PH 12/07/04				HORIZ. STYLE CONNECTOR		
J N06-0259	HB 10/12/06	xxx ±0.10			USB+POWER ASSEMBLY		
D T03-0157	WL 5/7/03	dr	WENDY CHEN	06/07/02	unit	product family	code
E T04-0191	WL 5/4/04	engr	R Y LIU	06/07/02	mm	USB	
F T04-0264	WL 06/21/04	chr	R Y LIU	06/07/02	scale	dwg no.	sheet
G N04-0033	PH 07/30/04	dppd	JENN TSMO	06/07/02		10011029	1 of 3
sheet revision	J	G	G				
index sheet	1	2	3				

1 2 3 4 5 6

WAS SK53049

PRODUCT NO.
10011029

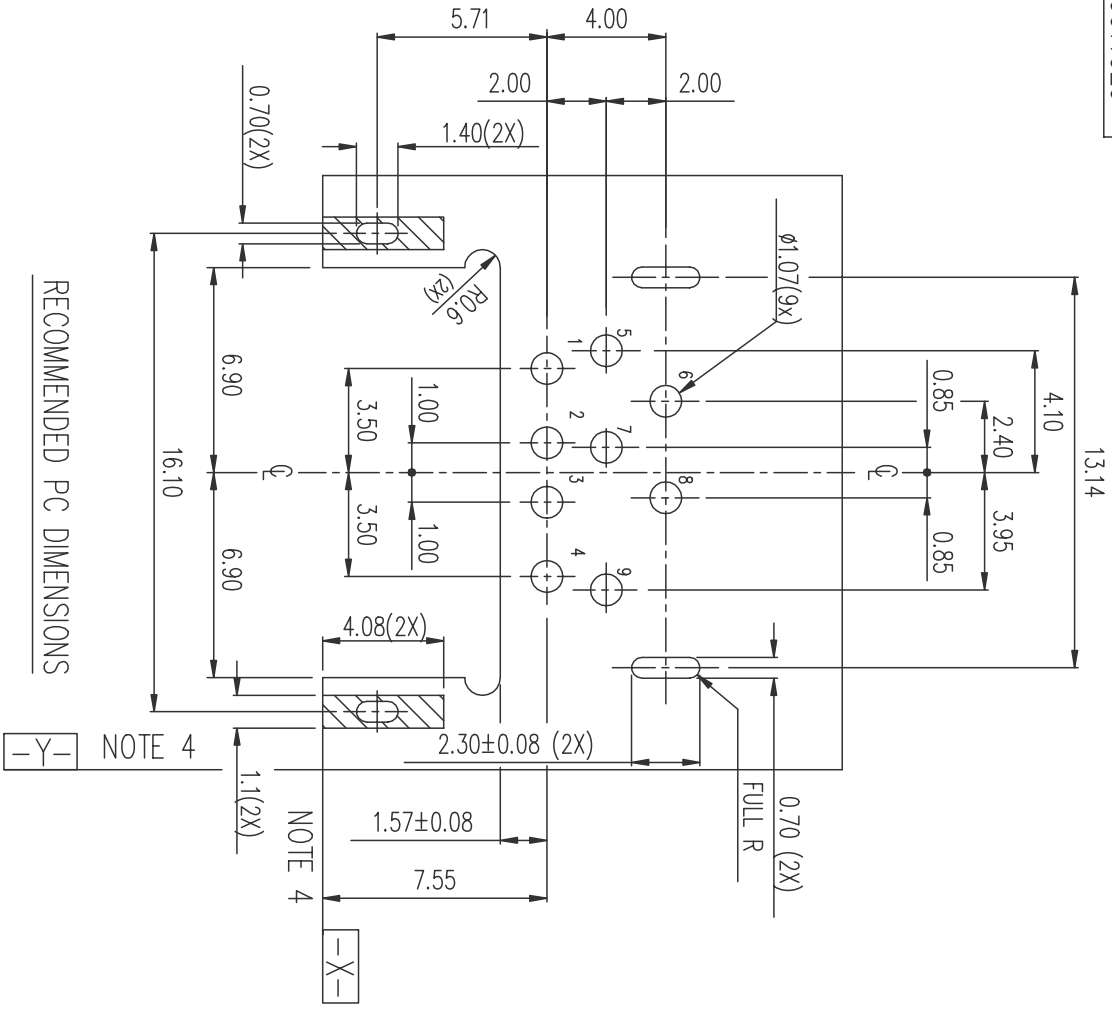

RECOMMENDED PC DIMENSIONS

- NOTES:
1. MATERIAL: HOUSINGS : HIGH TEMP ENGINEERING PLASTIC UL 94V-0 SHIELDS: HIGH STRENGTH COPPER ALLOY, PLATING: NICKEL
 2. USB SECTION CONFORMS TO USB 2.0 SPECIFICATION
 3. RECOMMEND PC BOARD THICKNESS SEE P/N CODE
 4. DATUM AND BASIC DIMENSIONS ESTABLISHED BY CUSTOMER
 5. RECOMMENDED PCB THICKNESS 1.2mm.
 6. DENOTED <ST> REQUIREMENT CPK.
 7. P/N 10011029-XXXXRP FOR TAPE & REEL PACKAGING.
 8. THIS PRODUCT IS MADE UNDER LICENSE OF IBM U.S. PATENT NO. 6334793

CONFIDENTIAL

mat'l code	tolerance unless otherwise specified	CUSTOMER COPY	title	product family	code
rev. econ no. dr. date	.X ±0.30	FCI	HORIZ. STYLE CONNECTOR USB+POWER ASSEMBLY	USB	2 of
G	linear .XX ±0.20	projection	product size	dwg no.	sheet
	angles .XXX ±0.10	dr WENDY CHEN/06/07/02	A3	10011029	2 of
	dr R Y LIU	engr R Y LIU	scale		
	chr JENN TSAO	pppl JENN TSAO	06/07/02		
sheet revision					
index sheet					

1 2 3 4 5 6

WAS SK53049



PRODUCT NO.
10011029

PRODUCT NUMBER CODE

10011029-

X

X

X

X

X

P

LF

BASE PRODUCT NUMBER

HOUSING COLOR + SHELL PLATING OPTIONS

1 - BLACK

SHELL PLATING OPTION

0 - NICKEL PLATING ONLY

SHELL OPTIONS

2 - NO BACK SHIELD

TERMINAL PLATING OPTION

0 - 50u" NI UNDERPLATE

30u" AU CONTACT AREA

100u" TIN/LEAD TAIL AREA

1 - 50u" NI UNDERPLATE

30u" AU CONTACT AREA

100u" TIN TAIL AREA

PACKAGING OPTIONS

R - TAPE & REEL

WITH DATE CODE

LEAD FREE MARK
WHEN TERMINAL PLATING OPTION IS 1

mat'l code	tolerance unless otherwise specified	CUSTOMER COPY	title	product family	code
rev. econ no. dr. date	.X ±0.20		HORIZ. STYLE CONNECTOR	USB	sheet 3 of 3
G	linear .XX ±0.10		USB+POWER ASSEMBLY		
	xxxx ±0.05				
	angles 0 ±.2°				
	dr WENDY CHEN/06/07/02	projection			
	enqr R Y LIU 06/07/02	unit			
	chr R Y LIU 06/07/02	mm/Inch			
	pppd JENN TSAO 06/07/02	scale			
sheet revision					
index sheet					

1 2 3 4 5 6

WAS SK53049