

# 9176 Series

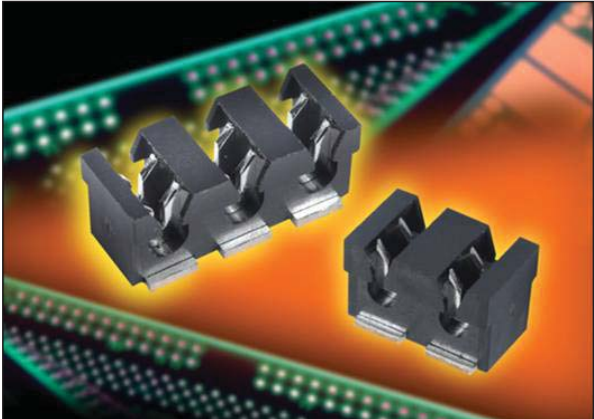

## Wire to Board Strip IDC Connector



The 9176 series from AVX offers customers the ability of connecting individual wires to a single row of contacts using IDC technology.

Available as a 2 or 3 pin connector it is both low profile and has a small PCB footprint. The connector is SMT assembled to the PCB prior to assembly of the wire.

Using a small application tool, the wires are then inserted into the contact slot. This process cuts the insulation and enables the individual conductors of the wire to form a homogeneous joint. The shape of the molding also forms a restraint to the wire when fully inserted in the contact. These connectors are supplied in tape and reel for easy pick and place. The wire options are 18 to 24 AWG stranded wire.

### APPLICATIONS

- PCB to PCB individual wire interconnect
- Device to PCB interconnect (LED Modules and LED Strips)

### FEATURES AND BENEFITS

- Small single row IDC
- Rated at 10 amps
- Uses both stranded wire (18 to 24 gauge)
- Insulators are end to end stackable for higher pin counts
- Uses simple hand tool for higher volume applications

### HOW TO ORDER

00

Prefix

9176

Series

002

Number of Ways

002 = 2  
003 = 3

001

Wire Gauge Size

Code	Accepted Wire Gauge	Wire Insulation
001	18 Gauge Stranded	Ø 1.6 - 2.1
011	20 Gauge Stranded	Ø 1.6 - 2.1
022	22 Gauge Stranded	Ø 1.1 - 1.6
032	24 Gauge Stranded	Ø 1.1 - 1.6

006

Plating Option

006 = Pure Tin All Over



# 9176 Series



## Wire to Board Strip IDC Connector

### 2 WAY IDC CONNECTOR

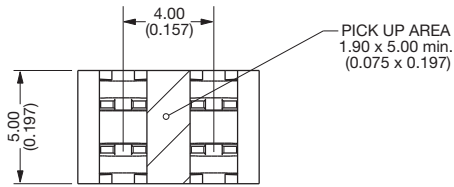

### 3 WAY IDC CONNECTOR

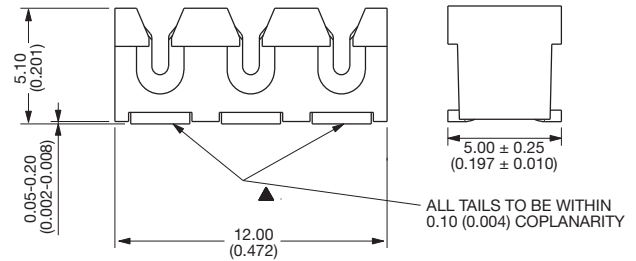
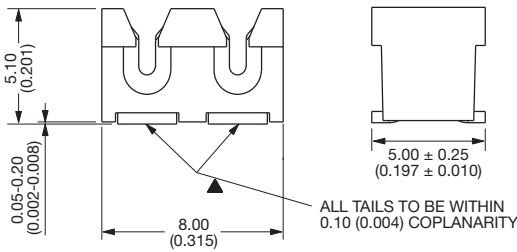
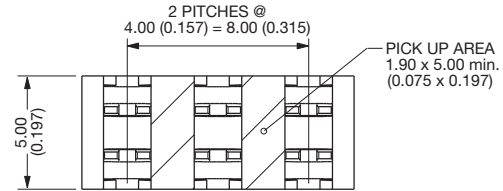

### SMT PCB LAYOUT

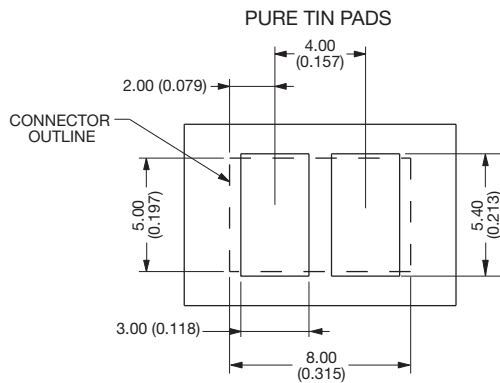

### SMT PCB LAYOUT

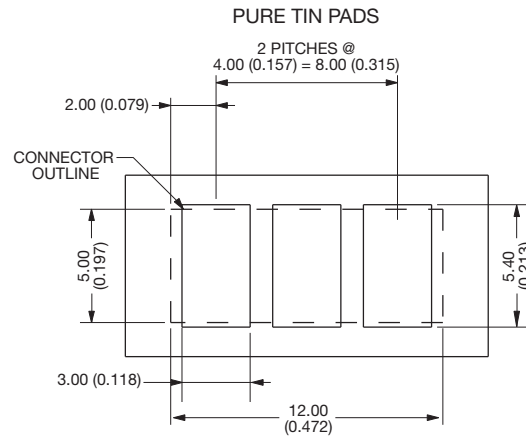

### HAND INSERTION TOOLING

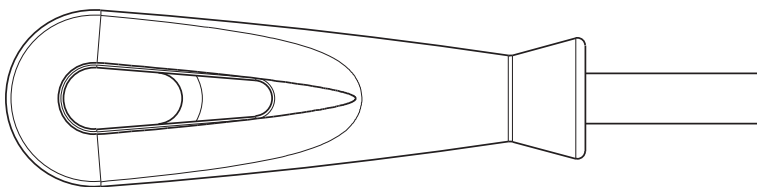

#### UNIVERSAL HANDLE

Details	Tool Part Number
6.35 A/F HEX BIT HOLDER	06 7000 7730 01 000

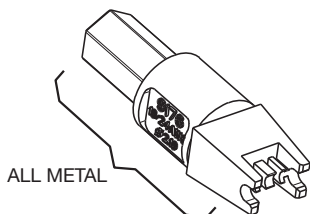

#### HIGH PRODUCTION Metal

Max Insulation Dia	Tool Part Number
∅ 2.10	06 9176 7017 01 000
∅ 1.60	06 9176 7017 02 000

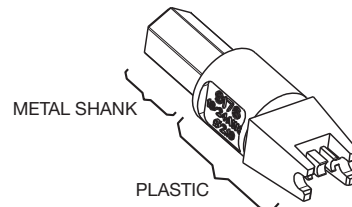

#### MED PRODUCTION Metal/Plastic

Max Insulation Dia	Tool Part Number
∅ 2.10	06 9176 7016 01 000
∅ 1.60	06 9176 7016 02 000

