

VIEW A
VERSION 2

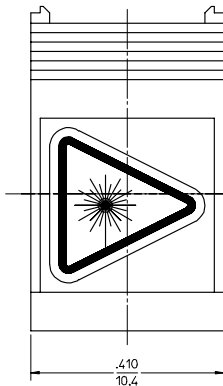

VIEW A
VERSION 1

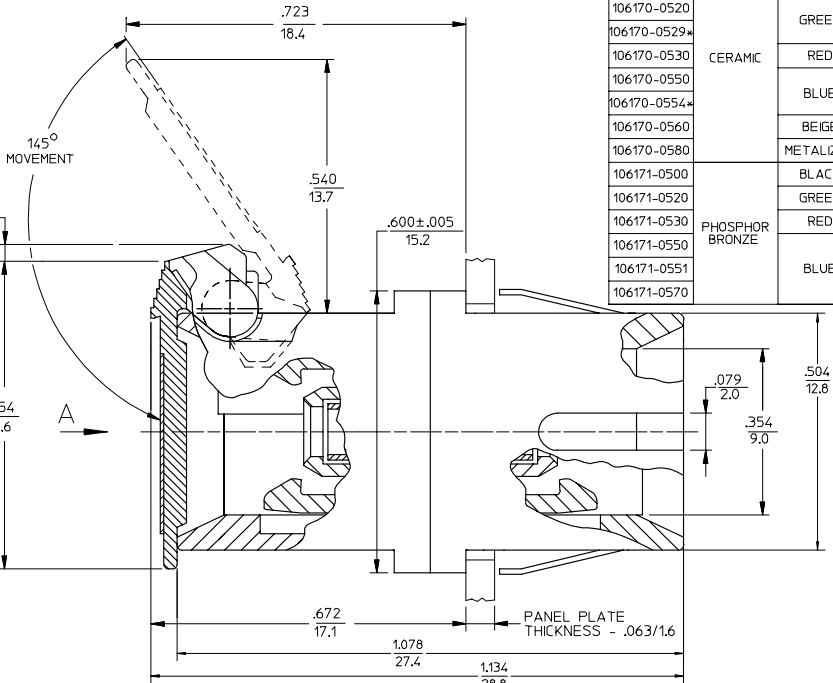

106170			
ADAPTER P/N	SPLIT SLEEVE MATERIAL	ADAPTER COLOR	METALIZED SHIELD
106170-0500	CERAMIC	BLACK	NO
106170-0520		GREEN	
106170-0529*		RED	
106170-0530		BLUE	
106170-0550		BEIGE	
106170-0560		METALIZED	
106171-0500	PHOSPHOR BRONZE	BLACK	NO
106171-0520		GREEN	
106171-0530		RED	
106171-0550		BLUE	
106171-0551			
106171-0570			YES

- NOTES:
1. LABEL MUST BE INSTALLED AND ORIENTED BY CUSTOMER (SEE VIEW A).
 2. DUST CAP IS NOT SHOWN, BUT INCLUDED.
 - *3. P/NS 106170-0529, 106170-0554, AND 106171-0551 ARE BULK PACKED IN QUANTITIES OF 100 PCS.

ENTER DESCRIPTION EC NO: MF2008-0173 DRAWN: SZENCZYK 2007/10/25 CHKD: 2007/10/25 APPR: GUMIN 2007/10/25	QUALITY SYMBOLS ▽=0 ▽=0	GENERAL TOLERANCES (UNLESS SPECIFIED)		DIMENSION STYLE IN/MM	SCALE 5:1	DESIGN UNITS INCH	THIRD ANGLE PROJECTION
		4 PLACES ± --- ± --- 3 PLACES ± --- ± --- 2 PLACES ± --- ± --- 1 PLACE ± --- ± ---	DRAWN BY RPACIFIC1 2005/10/13	TITLE SC ADAPTER, SMALL FLANGE WITH SHUTTER			
		ANGULAR ±1/2°	CHECKED BY DATE	MOLEX INCORPORATED			
		DRAFT WHERE APPLICABLE MUST REMAIN WITHIN DIMENSIONS	APPROVED BY DATE	MATERIAL NO. SEE TABLE	DOCUMENT NO. SD-1061XX-05X0	SHEET NO. 1 OF 01	