

List of "SFW__R-1/2STE9LF" customer document

DOCUMENT NO.	LIST
10101159(SHEET1)	DOCUMENT LIST
10101159(SHEET2)	CAT.NO.TABLE FOR 1mm SPACING SMT CONNECTOR (SFW__R-1/2ST__LF)
10101159(SHEET3)	1mm SPACING SMT CONNECTOR (SFW__R-1ST_LF)
10101159(SHEET4)	1mm SPACING SMT CONNECTOR (SFW__R-2ST_LF)
10101159(SHEET5)	CAT.NO.TABLE FOR PLASTIC TAPE PACKAGED 1mm SPACING SMT CONNECTOR (SFW__R-1/2STE9LF)
10101159(SHEET6)	PLASTIC TAPE PACKAGED 1mm SPACING SMT CONNECTOR (SFW__R-1STE9LF)
10101159(SHEET7)	PLASTIC TAPE PACKAGED 1mm SPACING SMT CONNECTOR (SFW__R-2STE9LF)
10101159(SHEET8)	RECOMMENDED CABLE (FPC) (SFW__R-1/2ST_)
10101159(SHEET9)	RECOMMENDED CABLE (FFC) (SFW__R-1/2ST_)
SC-SFW10	PRODUCT SPECIFICATION
GS-20-129	HANDLING PROCEDURES



FCIconnect.com

Copyright FCI.

mat'l. code		-		surface 58		tolerance		projection		product family		CODE	
				ISO 1302		ISO 406				58RF		JP	
				tolerances unless otherwise specified		ISO 1101				title			
ltr		ecn no		dr		date		angles		1mm SPACING SMT CONNECTOR DOCUMENT LIST			
A		S09-0138		DGOH		09-04-30		linear		(Cat. No. : SFW__R-1/2STE9LF)			
B		J09-0356		M.Y		2009-10-2							
C		J09-0380		M.Y		2009-10-27							
				dr		H. YAMASHITA 2009-10-27				dwg no		sheet 1 of 9 size	
				enrg		M. YAMASHITA 2009-10-27				10101159		A4	
				chr		J. W. K. 2009-10-27				type		Product Customer Drawing	
				appd		J. D. 2009-10-27							
sheet index		revision sheet		C		C		C		C		Rev. C	
				1		2		3		4		5	
				6		7		8		9			

CAT. NO. & DIMENSIONS

NO. OF CONTACTS (n)	CAT. NO.	DIMENSIONS (NOTE2)			
		A ± 0.2	B ± 0.2	C ± 0.2	D ± 0.1
4	SFW4R-1/2ST__LF	9.8	8.6	3.0	5.3
5	SFW5R-1/2ST__LF	10.8	9.6	4.0	6.3
6	SFW6R-1/2ST__LF	11.8	10.6	5.0	7.3
7	SFW7R-1/2ST__LF	12.8	11.6	6.0	8.3
8	SFW8R-1/2ST__LF	13.8	12.6	7.0	9.3
9	SFW9R-1/2ST__LF	14.8	13.6	8.0	10.3
10	SFW10R-1/2ST__LF	15.8	14.6	9.0	11.3
11	SFW11R-1/2ST__LF	16.8	15.6	10.0	12.3
12	SFW12R-1/2ST__LF	17.8	16.6	11.0	13.3
13	SFW13R-1/2ST__LF	18.8	17.6	12.0	14.3
14	SFW14R-1/2ST__LF	19.8	18.6	13.0	15.3
15	SFW15R-1/2ST__LF	20.8	19.6	14.0	16.3
16	SFW16R-1/2ST__LF	21.8	20.6	15.0	17.3
17	SFW17R-1/2ST__LF	22.8	21.6	16.0	18.3
18	SFW18R-1/2ST__LF	23.8	22.6	17.0	19.3
19	SFW19R-1/2ST__LF	24.8	23.6	18.0	20.3
20	SFW20R-1/2ST__LF	25.8	24.6	19.0	21.3
21	SFW21R-1/2ST__LF	26.8	25.6	20.0	22.3
22	SFW22R-1/2ST__LF	27.8	26.6	21.0	23.3
23	SFW23R-1/2ST__LF	28.8	27.6	22.0	24.3
24	SFW24R-1/2ST__LF	29.8	28.6	23.0	25.3
25	SFW25R-1/2ST__LF	30.8	29.6	24.0	26.3
26	SFW26R-1/2ST__LF	31.8	30.6	25.0	27.3
27	SFW27R-1/2ST__LF	32.8	31.6	26.0	28.3
28	SFW28R-1/2ST__LF	33.8	32.6	27.0	29.3
29	SFW29R-1/2ST__LF	34.8	33.6	28.0	30.3
30	SFW30R-1/2ST__LF	35.8	34.6	29.0	31.3

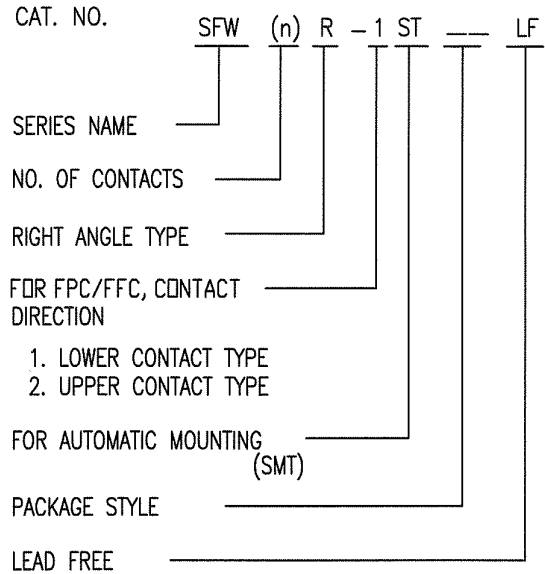

NOTES

1. THIS PRODUCT IS THE CONNECTOR USED FOR FPC/FFC AND COPER WITH AUTOMATIC MOUNTING (SMT).
2. SEE PART DRAWINGS FOR DIMENSIONS A~D.



FCIconnect.com

Copyright FCI.

mat'l. code		surface 58 / tolerance ISO 406 / ISO 1101		projection		product family 58RF		CODE JP	
ltr	ecn no	dr	date	tolerances unless otherwise specified		title		CAT. NO. TABLE FOR 1mm SPACING SMT CONNECTOR (Cat. No. SFW__R-1/2ST__LF)	
c				angles	linear	mm	dwg no		sheet 2 of 9
						scale X	10101159		A4
		dr	M. YAMASHITA 2008-10-27	FCI		type		Product Customer Drawing	
		enfr	M. YAMASHITA 2008-10-27					Rev. C	
		chr	S. W. H. 2008-10-27						
		appd	S. D. 2008-10-27						
sheet index	revision sheet								

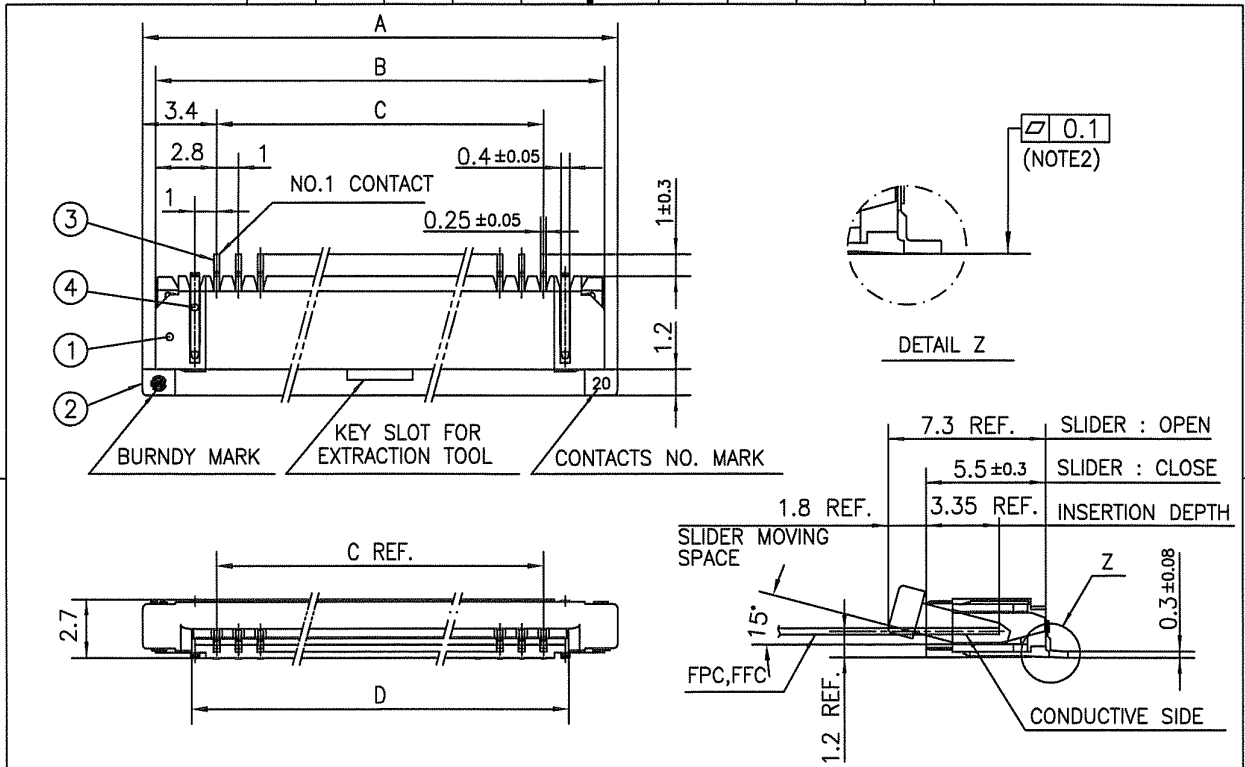

PT. NO.	PARTS NAME	MATERIAL	Q'TY	NOTE
1	HOUSING	PPS RESIN GLASS REINFORCED (UL94V-0)	1	COLOR : BROWN
2	SLIDER	PPS RESIN GLASS REINFORCED (UL94V-0)	1	COLOR : BLACK
3	CONTACT	PHOSPHOR BRONZE	n	PLATING : TIN
4	MOUNTING PLATE		2	

n : NO. OF CONTACTS

RECOMMENDED PC BOARD LAYOUT
(COMPONENT SIDE)

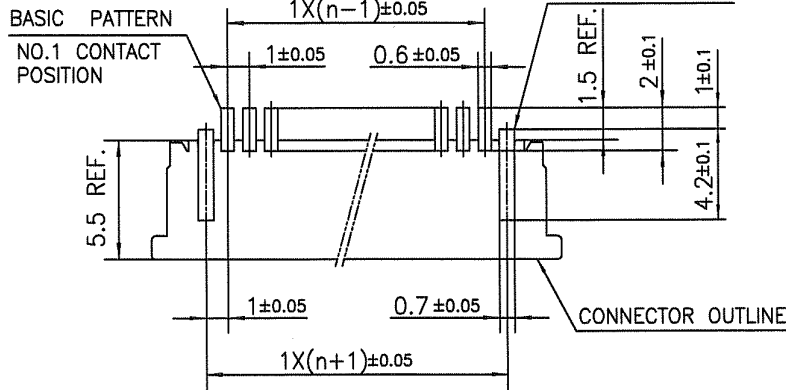

NOTES

1. THIS PRODUCT IS THE CONNECTOR USED FOR FPC/FFC AND COPEs WITH AUTOMATIC MOUNTING (SMT).
2. FLATNESS FOR CONTACT TERMINAL HOUSING MUST BE WITHIN TOLERANCE IN Z PORTION DETAILED DRAWING.
3. THIS PRODUCT IS LOWER CONTACT TYPE CONNECTOR.
4. THIS PRODUCT MEETS EUROPEAN UNION DIRECTIVES AND OTHER COUNTRY REGULATIONS AS DESCRIBED IN GS-22-008
5. THE HOUSING WILL WITHSTAND EXPOSURE TO 260°C PEAK TEMPERATURE FOR 10 SECONDS IN A REFLOW SOLDERING OVEN.

mat'l. code		surface 58		tolerance ISO 1302		projection		product family 58RF		CODE JP	
ltr		ecn no		dr		date		title		1mm SPACING SMT CONNECTOR (Cat. No. SFW__R-1ST__LF)	
c		angles		linear		mm		scale		X	
sheet index		revision sheet		dr		M.YAMASOUBA 2008-10-27		engr		M.YAMASOUBA 2008-10-27	
				chr		S. Nishida 2008-10-27		appd		S. Oshida 2008-10-27	
				dwg no		sheet 3 of 9		size		A4	
				type		Product Customer Drawing		10101159			
										Rev. C	

form: A4

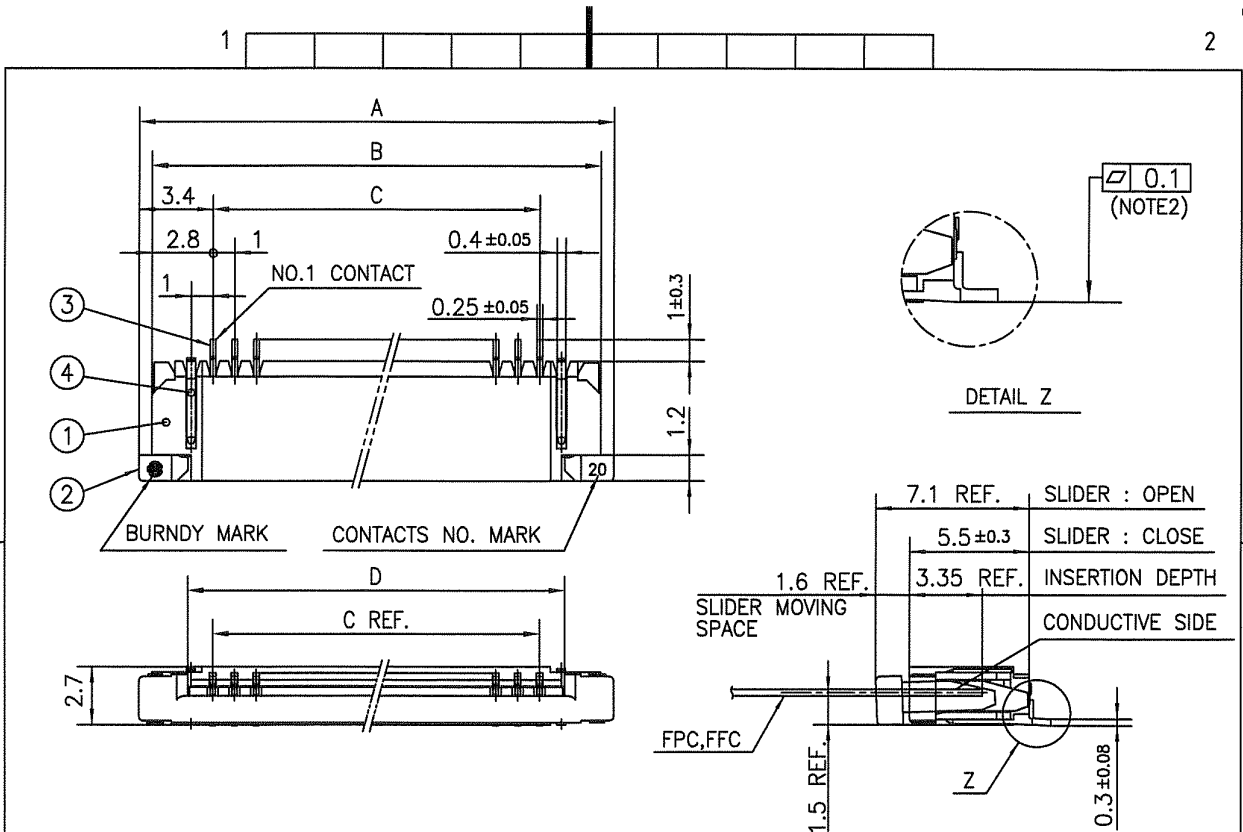

PT. NO.	PARTS NAME	MATERIAL	Q'TY	NOTE
1	HOUSING	PPS RESIN GLASS REINFORCED (UL94V-0)	1	COLOR : BROWN
2	SLIDER		1	COLOR : BLACK
3	CONTACT	PHOSPHOR BRONZE	n	PLATING : TIN
4	MOUNTING PLATE		2	

n : NO. OF CONTACTS

RECOMMENDED PC BOARD LAYOUT
(COMPONENT SIDE)

BASIC PATTERN
NO.1 CONTACT
POSITION

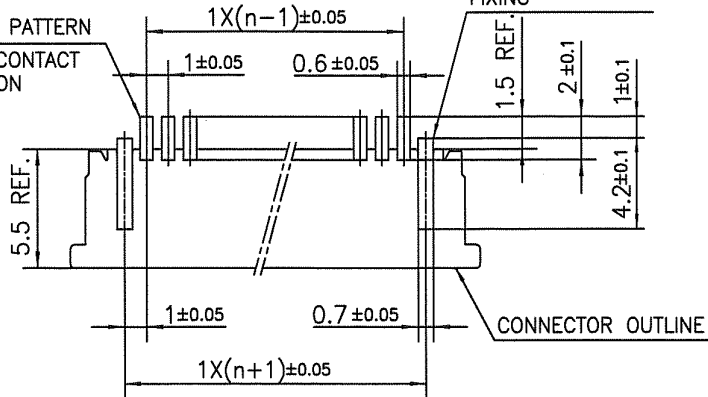

NOTES

1. THIS PRODUCT IS THE CONNECTOR USED FOR FPC/FFC AND COPES WITH AUTOMATIC MOUNTING (SMT).
2. FLATNESS FOR CONTACT TERMINAL HOUSING MUST BE WITHIN TOLERANCE IN Z PORTION DETAILED DRAWING.
3. THIS PRODUCT IS UPPER CONTACT TYPE CONNECTOR.
4. THIS PRODUCT MEETS EUROPEAN UNION DIRECTIVES AND OTHER COUNTRY REGULATIONS AS DESCRIBED IN GS-22-008
5. THE HOUSING WILL WITHSTAND EXPOSURE TO 260°C PEAK TEMPERATURE FOR 10 SECONDS IN A REFLOW SOLDERING OVEN.

mat'l. code		surface 58 / tolerance ISO 1302 ✓ / ISO 406 / ISO 1101		projection		product family 58RF		CODE JP	
ltr		ecn no		dr		date		title	
C								1mm SPACING SMT CONNECTOR (Cat. No. SFW__R-2ST__LF)	
		angles		linear		mm		scale X	
		dr		M. YAMASHITA		2009-10-27		dwg no	
		enr		M. YAMASHITA		2009-10-27		sheet 4 of 9	
		chr		S. M. ...		2009-10-27		size	
		appd		S. ...		2009-10-27		A4	
sheet index		revision sheet						type Product Customer Drawing	
D								Rev. C	

form: A4

CAT. NO. & DIMENSIONS

NO. OF CONTACTS (n)	CAT. NO. (NOTE2)	DIMENSIONS (NOTE3)		
		E MAX.	F ± 0.3	G ± 0.1
4	SFW4R-1/2STE9LF	22.4	16	—
5	SFW5R-1/2STE9LF	30.4	24	—
6	SFW6R-1/2STE9LF	30.4	24	—
7	SFW7R-1/2STE9LF	30.4	24	—
8	SFW8R-1/2STE9LF	30.4	24	—
9	SFW9R-1/2STE9LF	30.4	24	—
10	SFW10R-1/2STE9LF	30.4	24	—
11	SFW11R-1/2STE9LF	30.4	24	—
12	SFW12R-1/2STE9LF	30.4	24	—
13	SFW13R-1/2STE9LF	38.4	32	28.4
14	SFW14R-1/2STE9LF	38.4	32	28.4
15	SFW15R-1/2STE9LF	38.4	32	28.4
16	SFW16R-1/2STE9LF	38.4	32	28.4
17	SFW17R-1/2STE9LF	50.4	44	40.4
18	SFW18R-1/2STE9LF	50.4	44	40.4
19	SFW19R-1/2STE9LF	50.4	44	40.4
20	SFW20R-1/2STE9LF	50.4	44	40.4
21	SFW21R-1/2STE9LF	50.4	44	40.4
22	SFW22R-1/2STE9LF	50.4	44	40.4
23	SFW23R-1/2STE9LF	50.4	44	40.4
24	SFW24R-1/2STE9LF	50.4	44	40.4
25	SFW25R-1/2STE9LF	50.4	44	40.4
26	SFW26R-1/2STE9LF	50.4	44	40.4
27	SFW27R-1/2STE9LF	50.4	44	40.4
28	SFW28R-1/2STE9LF	62.4	56	52.4
29	SFW29R-1/2STE9LF	62.4	56	52.4
30	SFW30R-1/2STE9LF	62.4	56	52.4

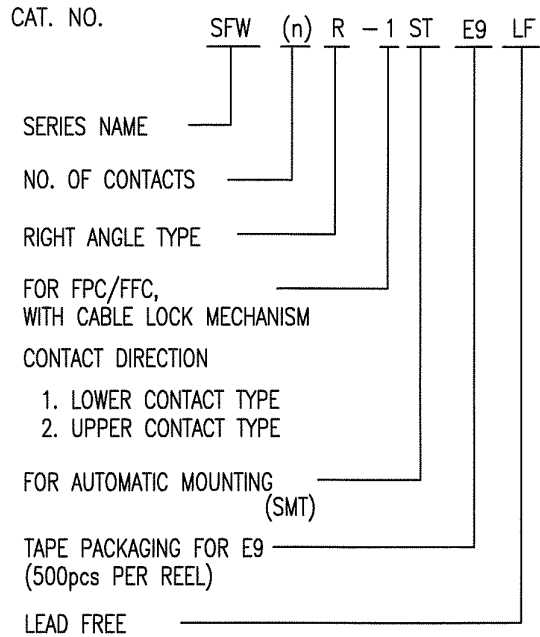

NOTES

1. THIS PRODUCT IS THE CONNECTOR USED FOR FPC/FFC AND COPELS WITH AUTOMATIC MOUNTING (SMT).
2. THIS CATALOG NO. INDICATES PLASTIC TAPE PACKAGED CONNECTOR.
3. SEE PART DRAWINGS FOR DIMENSIONS E~G.

mat'l. code		surface 58 / ISO 1302		tolerance ISO 406 / ISO 1101		projection		product family 58RF		CODE JP	
ltr		ecn no		dr		date		tolerances unless otherwise specified		title CAT NO. TABLE FOR PLASTIC TAPE PACKAGED 1mm SPACING SMT CONNECTOR (Cat. No. SFW__R-1/2STE9LF)	
c				angles		linear		mm		scale X	
				dr		2009-10-27		FCI		dwg no 10101159 sheet 5 of 9 size A4	
				enr		2009-10-27				type Product Customer Drawing	
				chr		2009-10-27				Rev. c	
				appd		2009-10-27				D	
sheet index		revision sheet									

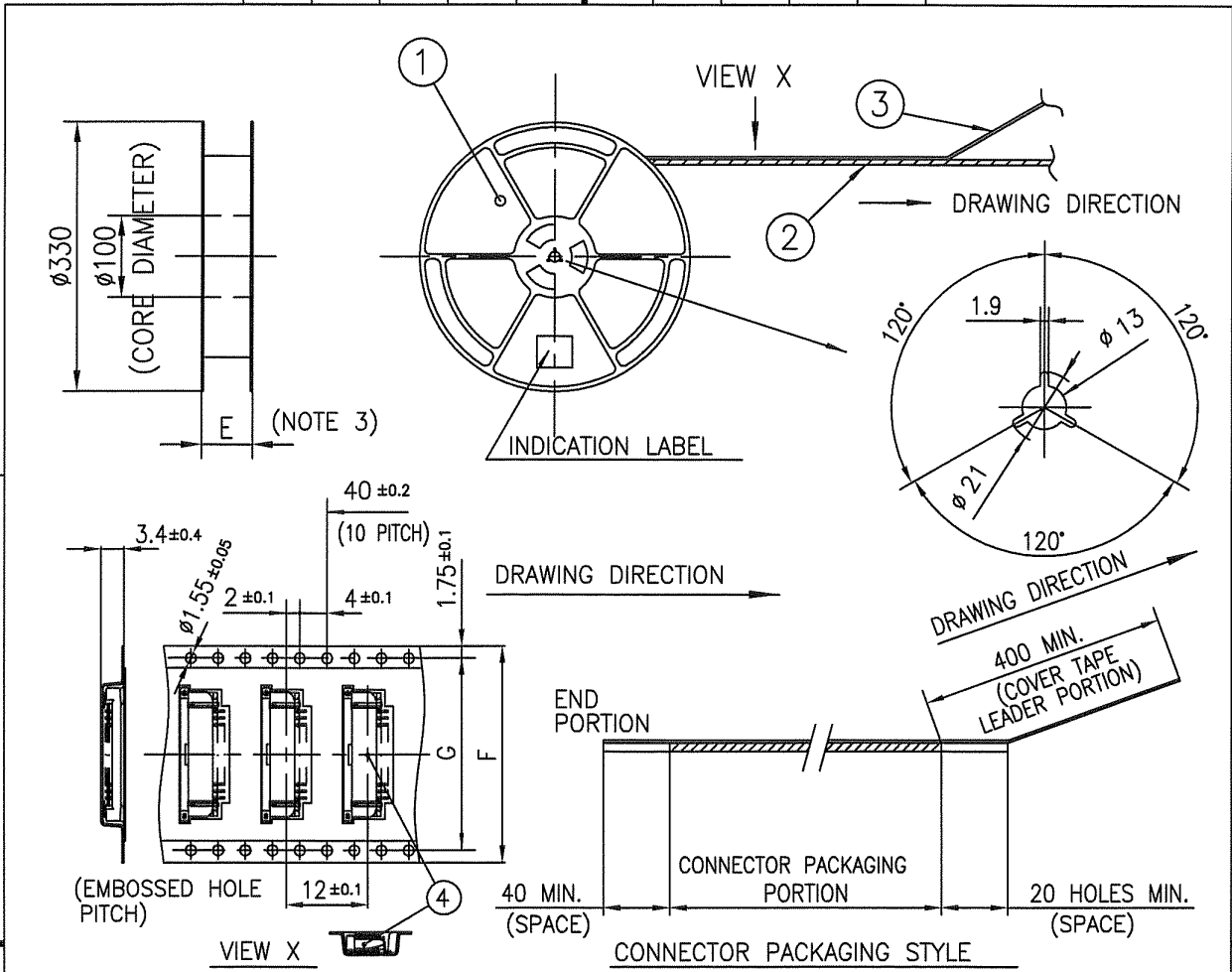

PT. NO.	PARTS NAME	CAT. NO.	MATERIAL	Q'TY	NOTE
1	REEL	_____	POLYSTYRENE	1	COLOR : WHITE or BLACK
2	PLASTIC (EMBOSS) TAPE	_____	PET	___	COLOR : TRANSPARENCY (CLEAR)
3	COVER	_____	POLYESTER	___	COLOR : TRANSPARENCY (CLEAR)
4	CONNECTOR	SFW__R-1ST__LF	SEE ATTACHED DWG.	500	LOWER CONTACT TYPE

- NOTES
- THIS IS PLASTIC TAPE PACKAGED CONNECTOR USED FOR FPC/FFC AND COPE WITH AUTOMATIC MOUNTING (SMT).
 - SEE JIS C 0806 (PACKING OF ELECTRONIC COMPONENTS ON CONTINUOUS TAPES (SURFACE MOUNTING DEVICES)) FOR SHAPE AND DIMENSIONS OF PLASTIC (EMBOSS) TAPE AND REEL.
 - E DIMENSION IS PORTION OF THE CORE.

mat'l. code		surface ISO 1302 <input checked="" type="checkbox"/>		tolerance ISO 406 <input checked="" type="checkbox"/> ISO 1101		projection		product family 58RF		CODE JP	
ltr		ecn no		dr		date		title		PLASTIC TAPE PACKAGED 1mm SPACING SMT CONNECTOR (Cat. No. SFW__R-1STE9LF)	
c				angles		linear		mm		scale \times	
				$\pm 5'$				dwg no		sheet 6 of 9 size	
				dr		14/AMBRETA 2008-10-27		FCJ		10101159 A4	
				enr		14/AMBRETA 2008-10-27		type		Product Customer Drawing	
				chr		S. Dudau 2008-10-27					
				appd		S. Dudau 2008-10-27					
sheet index		revision sheet								Rev. C	

form: A4



Copyright FCI.

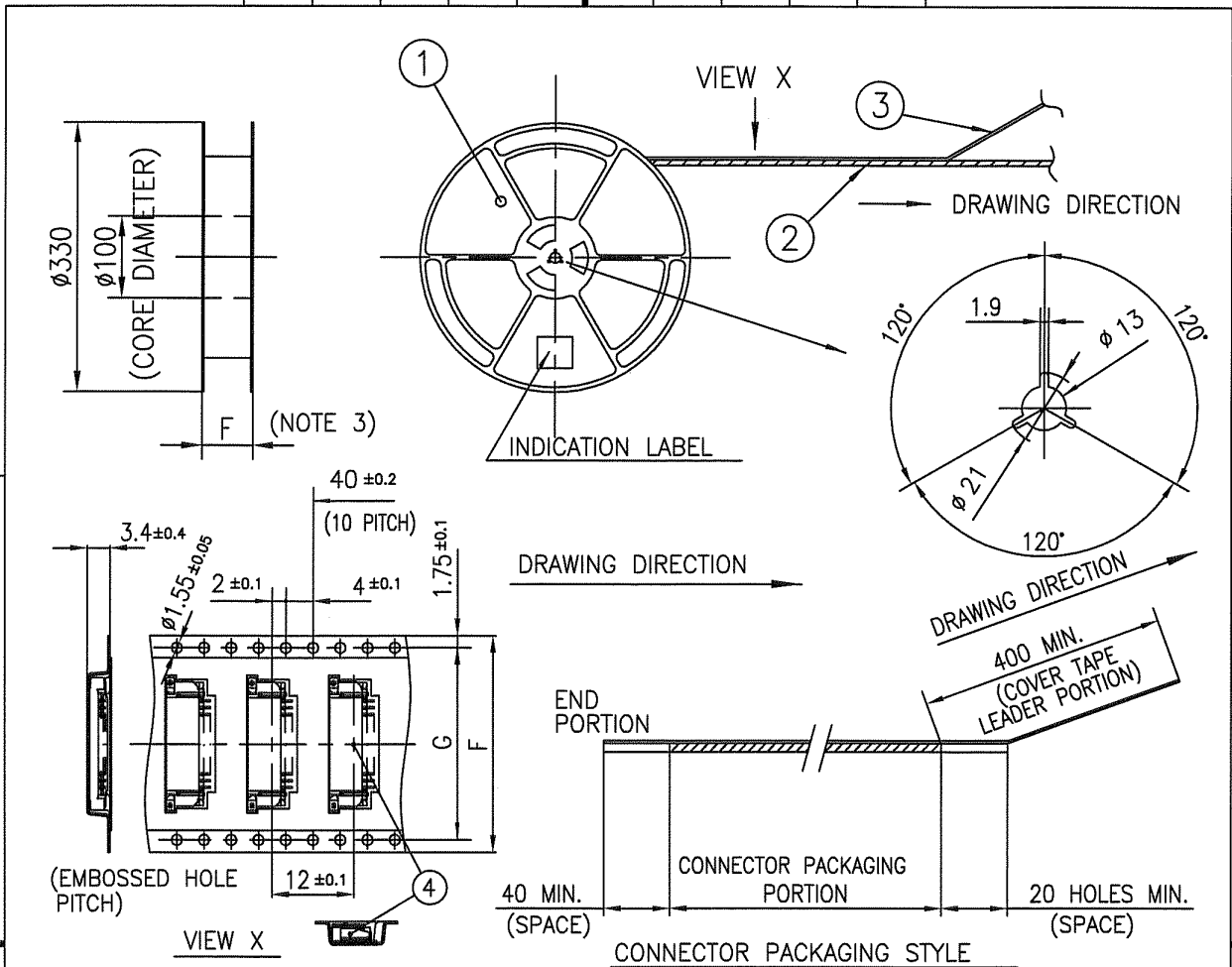

PT. NO.	PARTS NAME	CAT. NO.	MATERIAL	Q'TY	NOTE
1	REEL	_____	POLYSTYRENE	1	COLOR : WHITE or BLACK
2	PLASTIC (EMBOSS) TAPE	_____	PET	_____	COLOR : TRANSPARENCY (CLEAR)
3	COVER	_____	POLYESTER	_____	COLOR : TRANSPARENCY (CLEAR)
4	CONNECTOR	SFW__R-2ST__LF	SEE ATTACHED DWG.	500	UPPER CONTACT TYPE

NOTES

- THIS IS PLASTIC TAPE PACKAGED CONNECTOR USED FOR FPC/FFC AND COPEs WITH AUTOMATIC MOUNTING (SMT).
- SEE JIS C 0806 (PACKING OF ELECTRONIC COMPONENTS ON CONTINUOUS TAPES (SURFACE MOUNTING DEVICES)) FOR SHAPE AND DIMENSIONS OF PLASTIC (EMBOSS) TAPE AND REEL.
- E DIMENSION IS PORTION OF THE CORE.

mat'l. code		surface ISO 1302 <input checked="" type="checkbox"/>		tolerance ISO 406 <input checked="" type="checkbox"/>		projection		product family 58RF		CODE JP	
ltr		ecn no		dr		date		title		PLASTIC TAPE PACKAGED 1mm SPACING SMT CONNECTOR (Cat. No. SFW__R-2STE9LF)	
c		angles		linear		±5		mm		scale \times	
		±5'									
		dr		M. YAMASAKI		2008-10-29		dwg no		sheet 7 of 9 size	
		enr		M. YAMASAKI		2008-10-29		10101159		A4	
		chr		S. Ueda		2008-10-29		FCJ			
		appd		S. Ueda		2008-10-29		type		Product Customer Drawing	
sheet index		revision sheet								Rev. c	

RECOMMENDED CABLE (FPC)

n : NO. OF CONDUCTOR

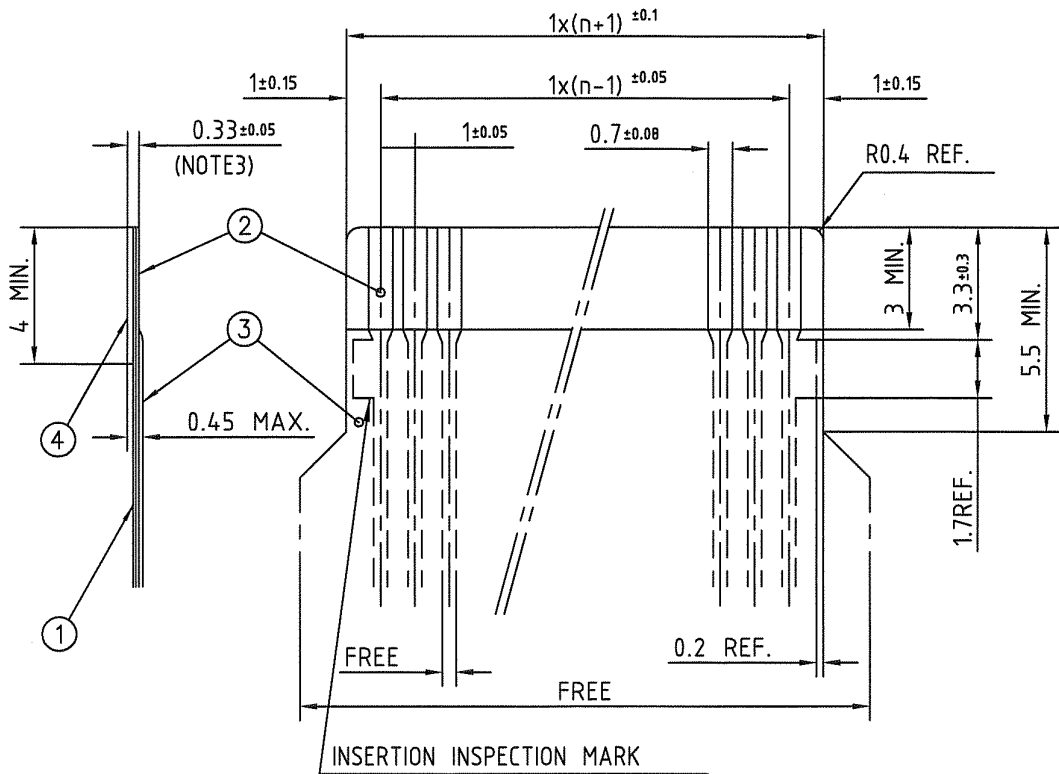

PT. NO.	PARTS NAME	MATERIAL	THICKNESS (um)
1	BASE FILM	POLYIMIDE OR POLYESTER OR EQUAL	25
2	CONDUCTOR	COPPER FOIL(PLATING:SOLDER 1um MIN.)	35
3	OVERLAY	POLYIMIDE OR POLYESTER OR EQUAL	—
4	SUPPORTING TAPE	POLYESTER OR POLYIMIDE OR EQUAL	188

NOTES

1. NO BURR AT EACH PORTION.
2. NO PEELING IN COMMON USE.
3. TOTAL THICKNESS LIMIT OF EACH MATERIAL (INCLUDING ADHESIVE AGENT) IS SPECIFIED.

mat'l. code		surface 58 / tolerance ISO 1302 / ISO 406 / ISO 1101		projection		product family 58RF		CODE JP	
ltr		ecn no		dr		date		title	
c								RECOMMENDED CABLE (Cat. No. SFW__R-1/2__)	
		angles		linear		mm		scale X	
		dr		M. YAMAGUCHI		2007-10-27		dwg no	
		enfr		M. YAMAGUCHI		2007-10-27		sheet 8 of 9	
		chr		S. Nishida		2007-10-27		size A4	
		appd		S. Nishida		2007-10-27		type Product Customer Drawing	
sheet index		revision sheet						Rev. c	

form: A4



FCIconnect.com

Copyright FCI.



RECOMMENDED CABLE (FFC)

n : NO. OF CONDUCTOR

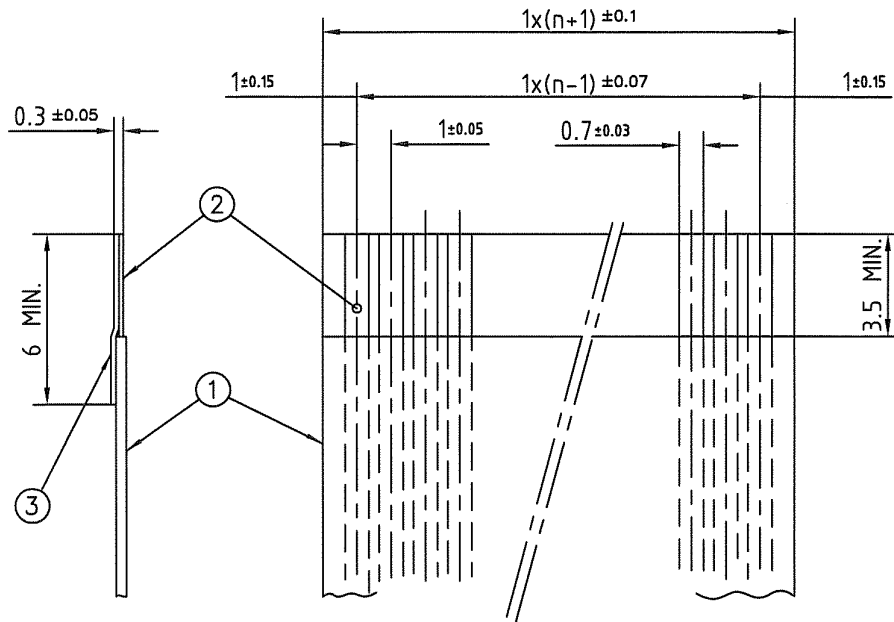

PT. NO.	PARTS NAME	MATERIAL	NOTE
1	INSULATOR	FLAME RESISTING POLYESTER OR EQUAL	_____
2	CONDUCTOR	COPPER FOIL	PLATING:TIN OR SOLDER 1um MIN.
3	SUPPORTING TAPE	FLAME RESISTING POLYESTER OR EQUAL	_____

NOTES

1. NO BURR AT EACH PORTION.
2. NO PEELING IN COMMON USE.

mat'l. code		surface 58 / tolerance ISO 1302 / ISO 406 / ISO 1101		projection		product family 58RF		CODE JP	
ltr	ecn no	dr	date	tolerances unless otherwise specified		title		RECOMMENDED CABLE	
C				angles	linear	mm		(Cat. No. SFW__R-1/2__)	
						scale X		dwg no 10101159	
				dr	M. YAMASHITA	2009-10-29	sheet 9 of 9		size A4
				enr	M. YAMASHITA	2009-10-27	type Product Customer Drawing		
				chr	S. Mitsu	2009-10-27			
				appd	P. Duda	2009-10-27			
sheet index	revision sheet								Rev. C



FCIconnect.com

Copyright FCI.

