

List of "SFV\_\_R-1/2STZE5LF" customer document

DOCUMENT NO.

LIST

SC-SFV03	SPEC.
JSA96914	CAT.NO.TABLE FOR 0.5mm CONTACT SPACING CONNECTOR (SFV__R-1/2STZ_LF)
JSA96915	CONNECTOR USED FOR FPC/FPC WITH 0.5mm CONTACT SPACING (SFV__R-1STZ_LF)
JSA96916	CONNECTOR USED FOR FPC/FPC WITH 0.5mm CONTACT SPACING (SFV__R-2STZ_LF)
JSA97162	CAT.NO.TABLE FOR PLASTIC TAPE PACKAGED 0.5mm CONTACT SPACING CONNECTOR (SFV__R-1/2STZE5LF)
JSA97163	PLASTIC TAPE PACKAGED 0.5mm CONTACT SPACING CONNECTOR (SFV__R-1STZE5LF)
JSA97164	PLASTIC TAPE PACKAGED 0.5mm CONTACT SPACING CONNECTOR (SFV__R-2STZE5LF)
JSA92456	RECOMMENDED CABLE (FPC) (SFV__R-1/2ST__)
JSA92457	RECOMMENDED CABLE (FFC) (SFV__R-1/2ST__)
BJM-SFV101	HANDLING PROCEDURES

mat'l. code				surface ISO 1302 <input checked="" type="checkbox"/>		tolerance ISO 406 ISO 1101		projection 		product family 58EF			
ltr		ecn no		dr		date		tolerances unless otherwise specified		title		sheet 1 of 1	
A		J06-0219		H.T		5/30/06		angles linear		0.5mm SPACING FPC/FFC CONNECTOR DOCUMENT LIST (Cat. No. : SFV__R-1/2STZE5LF)		size A4	
								scale $\times$		dwg no		JSA 97161	
										type		Customer Drawing	
sheet index		revision sheet		A		1						Rev. A	

form: A4



FCIconnect.com

Copyright FCI

CAT. NO. & DIMENSIONS

NO. OF CONTACTS (n)	CAT. NO.	DIMENSIONS (NOTE2)			
		A ± 0.2	B ± 0.2	C ± 0.1	D ± 0.1
4	SFV4R-1/2STZ__LF	7.5	5.9	1.5	2.7
5	SFV5R-1/2STZ__LF	8.0	6.4	2.0	3.2
6	SFV6R-1/2STZ__LF	8.5	6.9	2.5	3.7
7	SFV7R-1/2STZ__LF	9.0	7.4	3.0	4.2
8	SFV8R-1/2STZ__LF	9.5	7.9	3.5	4.7
9	SFV9R-1/2STZ__LF	10.0	8.4	4.0	5.2
10	SFV10R-1/2STZ__LF	10.5	8.9	4.5	5.7
11	SFV11R-1/2STZ__LF	11.0	9.4	5.0	6.2
12	SFV12R-1/2STZ__LF	11.5	9.9	5.5	6.7
13	SFV13R-1/2STZ__LF	12.0	10.4	6.0	7.2
14	SFV14R-1/2STZ__LF	12.5	10.9	6.5	7.7
15	SFV15R-1/2STZ__LF	13.0	11.4	7.0	8.2
16	SFV16R-1/2STZ__LF	13.5	11.9	7.5	8.7
17	SFV17R-1/2STZ__LF	14.0	12.4	8.0	9.2
18	SFV18R-1/2STZ__LF	14.5	12.9	8.5	9.7
19	SFV19R-1/2STZ__LF	15.0	13.4	9.0	10.2
20	SFV20R-1/2STZ__LF	15.5	13.9	9.5	10.7
21	SFV21R-1/2STZ__LF	16.0	14.4	10.0	11.2
22	SFV22R-1/2STZ__LF	16.5	14.9	10.5	11.7
23	SFV23R-1/2STZ__LF	17.0	15.4	11.0	12.2
24	SFV24R-1/2STZ__LF	17.5	15.9	11.5	12.7
25	SFV25R-1/2STZ__LF	18.0	16.4	12.0	13.2
26	SFV26R-1/2STZ__LF	18.5	16.9	12.5	13.7
27	SFV27R-1/2STZ__LF	19.0	17.4	13.0	14.2
28	SFV28R-1/2STZ__LF	19.5	17.9	13.5	14.7
29	SFV29R-1/2STZ__LF	20.0	18.4	14.0	15.2
30	SFV30R-1/2STZ__LF	20.5	18.9	14.5	15.7
31	SFV31R-1/2STZ__LF	21.0	19.4	15.0	16.2
32	SFV32R-1/2STZ__LF	21.5	19.9	15.5	16.7
33	SFV33R-1/2STZ__LF	22.0	20.4	16.0	17.2
34	SFV34R-1/2STZ__LF	22.5	20.9	16.5	17.7
35	SFV35R-1/2STZ__LF	23.0	21.4	17.0	18.2

CAT. NO. SFV (n) R - 1 ST Z \_\_ LF

SERIES NAME

NO. OF CONTACTS

RIGHT ANGLE TYPE

FOR FPC/FFC, CONTACT DIRECTION

1. LOWER CONTACT TYPE  
2. UPPER CONTACT TYPE

FOR AUTOMATIC MOUNTING (SMT)

PLATING VARIATION

PACKAGE STYLE

LEAD FREE

NOTES

- THIS PRODUCT IS THE CONNECTOR USED FOR FPC AND COPEs WITH AUTOMATIC MOUNTING (SMT).
- SEE PART DRAWINGS FOR DIMENSIONS A-D.



FCIconnect.com

Copyright FCI

mat'l. code				surface ISO 1302 <input checked="" type="checkbox"/>		tolerance ISO 406 ISO 1101		projection		product family 58EF	
ltr	ecn no	dr	date	tolerances unless otherwise specified				title		CAT. NO. TABLE FOR 0.5 mm CONTACT SPACING CONNECTOR (Cat. No. : SFV__R-1/2STZ__LF)	
A	J05-0859	H.T	'05/12/27	angles	linear			scale X		dwg no JSA 96914 sheet 1 of 1 size A4	
B	J06-0372	H.T	'06/9/17							type Product Customer Drawing	
sheet index		revision sheet	B 1							Rev. B	

SC-SFV03 JSA96915, 96916, 96917, 92456, 92457

form: A4

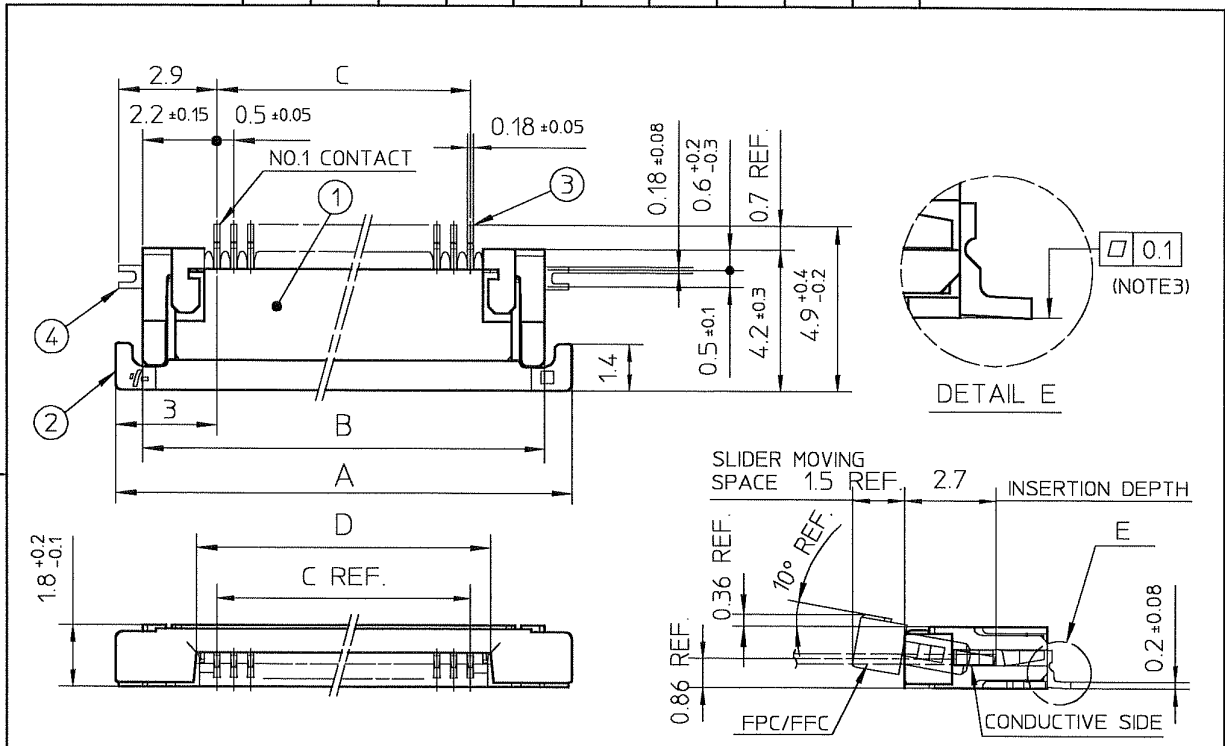

PT. NO.	PARTS NAME	MATERIAL	Q'TY	NOTE
1	HOUSING	POLYAMIDE RESIN GLASS REINFORCED (UL94V-0)	1	COLOR : BLACK
2	SLIDER	PPS RESIN GLASS REINFORCED (UL94V-0)	1	COLOR : BROWN
3	CONTACT	PHOSPHOR BRONZE	n	PLATING : THIN TIN
4	MOUNTING PLATE		2	PLATING : LEAD FREE

RECOMMENDED PC BOARD LAYOUT  
(COMPONENT SIDE)

PATTERN FOR MOUNTING PLATE  
FIXING

n : NO. OF CONTACTS

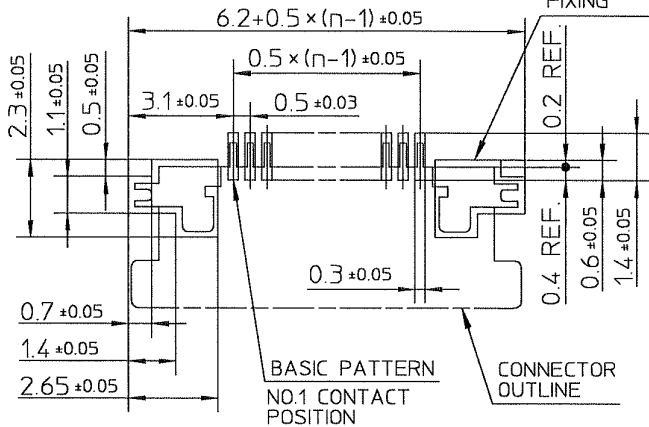

NOTES

1. THIS PRODUCT IS THE CONNECTOR USED FOR FPC/FFC AND COPER WITH AUTOMATIC MOUNTING (SMT).
2. THIS PRODUCT IS LOWER CONTACT TYPE CONNECTOR.
3. FLATNESS OF CONTACT TERMINAL AND MOUNTING PLATE MUST BE WITHIN TOLERANCE IN E PORTION DETAILED DRAWING.
4. THIS PRODUCT MEETS EUROPEAN UNION DIRECTIVES AND OTHER COUNTRY REGULATIONS AS DESCRIBED IN GS-22-008.
5. THE HOUSING WILL WITHSTAND EXPOSURE TO 260°C PEAK TEMPERATURE FOR 10 SECONDS IN A REFLOW SOLDERING OVEN.

mat'l. code				surface ISO 1302 ✓		tolerance ISO 406 ISO 1101		projection		product family 58EF	
ltr	ecn no	dr	date	tolerances unless otherwise specified				title		CONNECTION USED FOR FPC/FFC WITH 0.5 mm CONTACT SPACING (Cat No. : SFV__R-1STZ__LF)	
A	J05-0859	H.T	'05/12/27	angles		±0.2		scale X		dwg no sheet 1 of 1 size	
B	J06-0064	H.T	'06/2/23	linear				FCJ		JSA 96915 A4	
C	J06-0372	H.T	'06/9/17	dr		9/9/06				type Product Customer Drawing	
				enr		9/7/06					
				chr		9/8/06					
				appd		9/11/06					
sheet index	revision	C								Rev. C	
	sheet	1									

SC-SFV03 JSA96914 form: A4



FCJconnect.com

Copyright FCJ



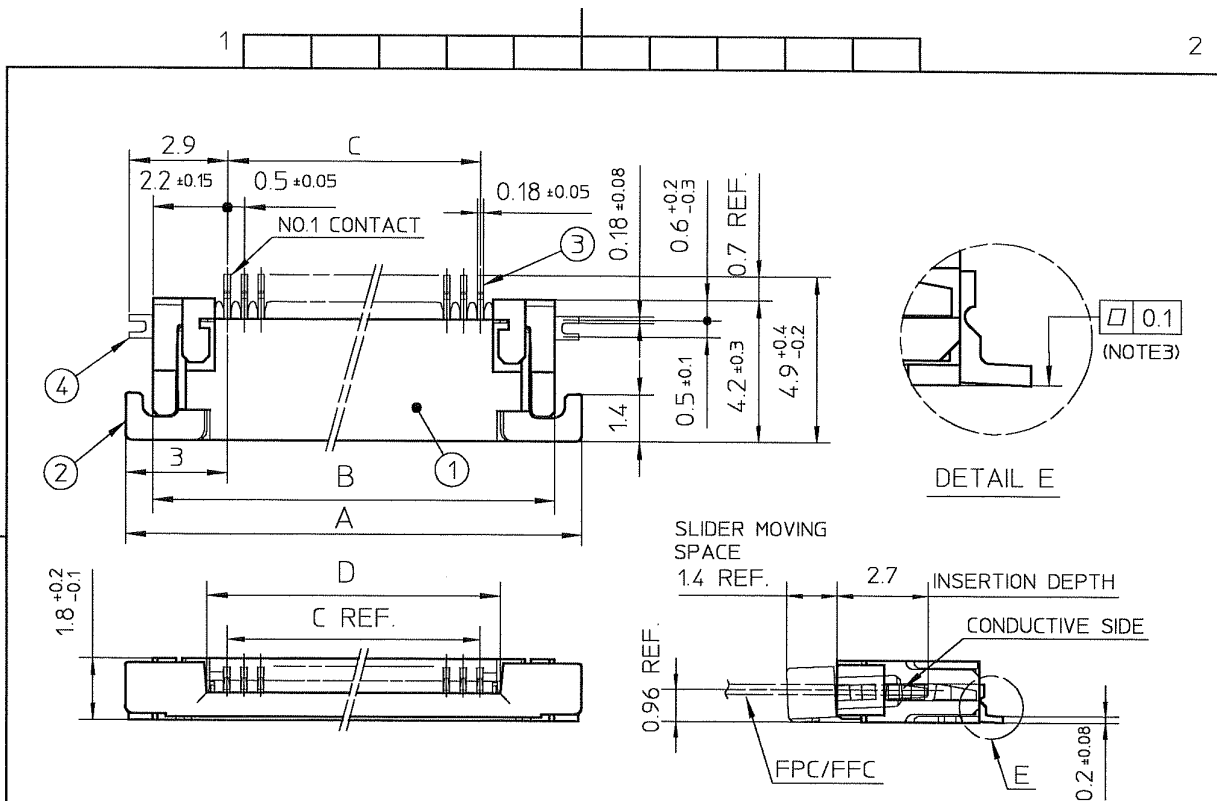

PT. NO.	PARTS NAME	MATERIAL	Q'TY	NOTE
1	HOUSING	POLYAMIDE RESIN GLASS REINFORCED (UL94V-0)	1	COLOR : BLACK
2	SLIDER	PPS RESIN GLASS REINFORCED (UL94V-0)	1	COLOR : BROWN
3	CONTACT	PHOSPHOR BRONZE	n	PLATING : THIN TIN
4	MOUNTING PLATE		2	PLATING : LEAD FREE

RECOMMENDED PC BOARD LAYOUT  
(COMPONENT SIDE)

PATTERN FOR  
MOUNTING PLATE  
FIXING

n : NO. OF CONTACTS

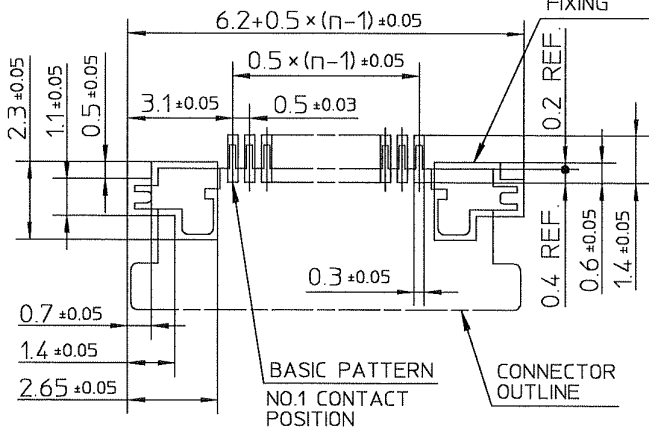

NOTES

1. THIS PRODUCT IS THE CONNECTOR USED FOR FPC/FFC AND COPES WITH AUTOMATIC MOUNTING (SMT).
2. THIS PRODUCT IS UPPER CONTACT TYPE CONNECTOR.
3. FLATNESS OF CONTACT TERMINAL AND MOUNTING PLATE MUST BE WITHIN TOLERANCE IN E PORTION DETAILED DRAWING.
4. THIS PRODUCT MEETS EUROPEAN UNION DIRECTIVES AND OTHER COUNTRY REGULATIONS AS DESCRIBED IN GS-22-008.
5. THE HOUSING WILL WITHSTAND EXPOSURE TO 260°C PEAK TEMPERATURE FOR 10 SECONDS IN A REFLOW SOLDERING OVEN.

mat'l. code				surface ISO 1302	tolerance ISO 406 ISO 1101	projection	product family 58EF	
ltr	ecn no	dr	date	tolerances unless otherwise specified			title	
A	J05-0859	H.T	'05/12/27	angles	±0.2		CONNECTOR USED FOR FPC/FFC WITH 0.5 mm CONTACT SPACING (Cat. No. : SFV__R-2STZ__LF)	
B	J06-0064	H.T	'06/2/23	linear			dwg no	
C	J06-0372	H.T	'06/9/7				sheet 1 of 1	
				dr	9/19/06		size	
				engr	9/19/06		A4	
				chr	9/18/06		JSA 96916	
				appd	9/19/06		type Product Customer Drawing	
sheet index	revision sheet	C	1					Rev. C

SC-SFV03 JSA96914 form: A4



FCIconnect.com

Copyright FCI

CAT. NO. & DIMENSIONS

NO. OF CONTACTS (n)	CAT. NO.	DIMENSIONS (NOTE3)		
		F MAX	G ± 0.3	H ± 0.1
4	SFV4R-1/2STZE5LF	22.4	16	—
5	SFV5R-1/2STZE5LF	22.4	16	—
6	SFV6R-1/2STZE5LF	22.4	16	—
7	SFV7R-1/2STZE5LF	30.4	24	—
8	SFV8R-1/2STZE5LF	30.4	24	—
9	SFV9R-1/2STZE5LF	30.4	24	—
10	SFV10R-1/2STZE5LF	30.4	24	—
11	SFV11R-1/2STZE5LF	30.4	24	—
12	SFV12R-1/2STZE5LF	30.4	24	—
13	SFV13R-1/2STZE5LF	30.4	24	—
14	SFV14R-1/2STZE5LF	30.4	24	—
15	SFV15R-1/2STZE5LF	30.4	24	—
16	SFV16R-1/2STZE5LF	30.4	24	—
17	SFV17R-1/2STZE5LF	30.4	24	—
18	SFV18R-1/2STZE5LF	30.4	24	—
19	SFV19R-1/2STZE5LF	30.4	24	—
20	SFV20R-1/2STZE5LF	30.4	24	—
21	SFV21R-1/2STZE5LF	30.4	24	—
22	SFV22R-1/2STZE5LF	30.4	24	—
23	SFV23R-1/2STZE5LF	38.4	32	28.4
24	SFV24R-1/2STZE5LF	38.4	32	28.4
25	SFV25R-1/2STZE5LF	38.4	32	28.4
26	SFV26R-1/2STZE5LF	38.4	32	28.4
27	SFV27R-1/2STZE5LF	38.4	32	28.4
28	SFV28R-1/2STZE5LF	38.4	32	28.4
29	SFV29R-1/2STZE5LF	38.4	32	28.4
30	SFV30R-1/2STZE5LF	38.4	32	28.4
31	SFV31R-1/2STZE5LF	50.4	44	40.4
32	SFV32R-1/2STZE5LF	50.4	44	40.4
33	SFV33R-1/2STZE5LF	50.4	44	40.4
34	SFV34R-1/2STZE5LF	50.4	44	40.4
35	SFV35R-1/2STZE5LF	50.4	44	40.4

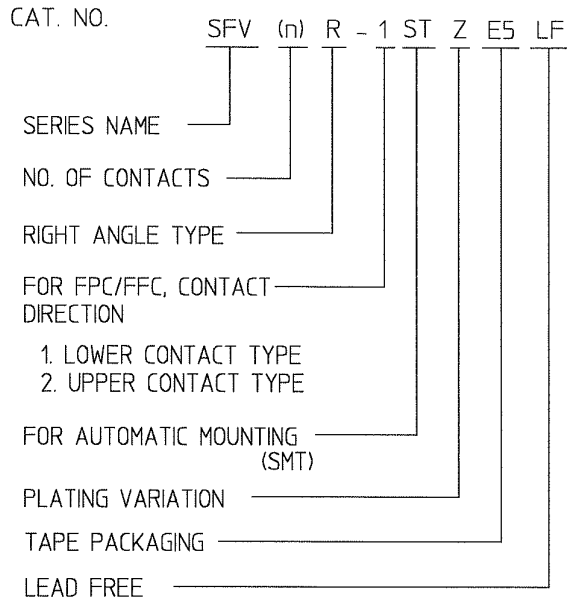

NOTES

1. THIS PRODUCT IS THE CONNECTOR USED FOR FPC AND COPEs WITH AUTOMATIC MOUNTING (SMT).
2. THIS CATALOG NO. INDICATES PLASTIC TAPE PACKAGED CONNECTOR.
3. SEE PART DRAWINGS FOR DIMENSIONS F-H.



FCIconnect.com

Copyright FCI

mat'l. code		surface ISO 1302 ✓		tolerance ISO 406 ISO 1101		projection		product family 58EF	
ltr	ecn no	dr	date	tolerances unless otherwise specified		title		sheet 1 of 1	
A	J06-0219	H.T	5/30/06	angles	linear	CAT. NO. TABLE FOR PLASTIC TAPE PACKAGED 0.5 mm CONTACT SPACING CONNECTOR (Cat. No. : SFV__R-1/2STZE5LF)		size A4	
		dr				scale X		sheet 1 of 1	
		enr				FCI		JSA 97162	
		chr						Customer Drawing	
		appd						type	
sheet index	revision sheet	A	1					Rev. A	

form: A4

SC-SFV03 JSA96914 97163 97164

1

2

TOLERANCES  
UNLESS OTHERWISE SPECIFIED : ±5, ANGLE ±5°

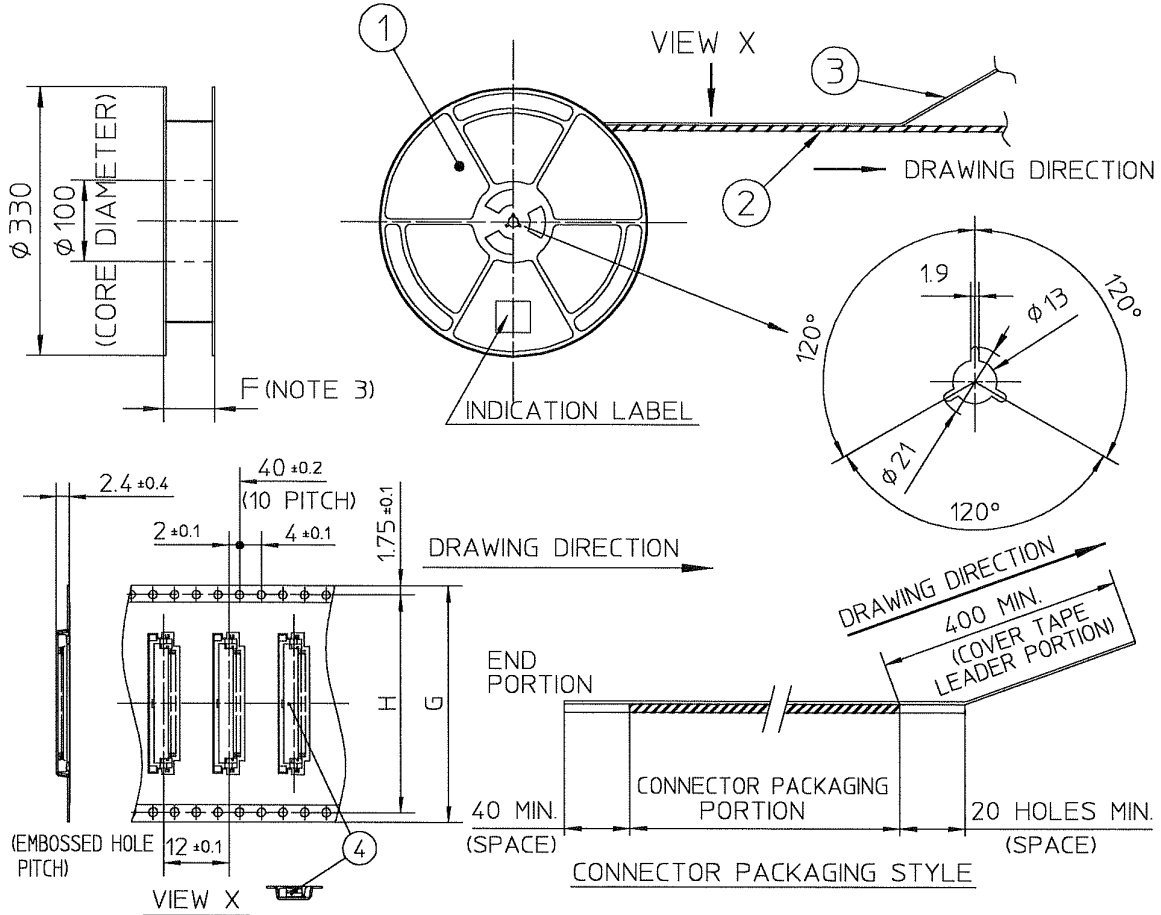

PT. NO.	PARTS NAME	CAT. NO.	MATERIAL	Q'TY	NOTE
1	REEL	—	POLYSTYRENE	1	COLOR : BLACK
2	PLASTIC (EMBOSS) TAPE	—	A-PET	—	COLOR : TRANSPARENCY
3	COVER	—	POLYESTER	—	COLOR : TRANSPARENCY
4	CONNECTOR	SFV_R-1STZ_LF	SEE ATTACHED DWG.	2500	LOWER CONTACT TYPE

NOTES

- THIS IS PLASTIC TAPE PACKAGED CONNECTOR USED FOR FPC AND COPES WITH AUTOMATIC MOUNTING (SMT).
- SEE JIS C 0806 (PACKING OF ELECTRONIC COMPONENTS ON CONTINUOUS TAPES (SURFACE MOUNTING DEVICES)) FOR SHAPE AND DIMENSIONS OF PLASTIC (EMBOSS) TAPE AND REEL.
- F DIMENSION IS PORTION OF THE CORE.

mat'l. code		surface ISO 1302 ✓		tolerance ISO 406 ISO 1101		projection ⊕		product family 58EF	
ltr		ecn no		date		tolerances unless otherwise specified		title PLASTIC TAPE PACKAGED 0.5 mm CONTACT SPACING CONNECTOR (Cat. No. : SFV_R-1STZE5LF)	
A		J06-0219		H.T 5/30/06		angles linear		scale X	
		dr		engr		appd		dwg no JSA 97163	
		5/30/06		5/30/06		5/30/06		sheet 1 of 1 A4	
								type Customer Drawing	
sheet index		revision sheet A 1						Rev. A	

form: A4 SC-SFV03 JSA97162



FCIconnect.com

Copyright FCI



TOLERANCES  
UNLESS OTHERWISE SPECIFIED : ±5, ANGLE ±5°

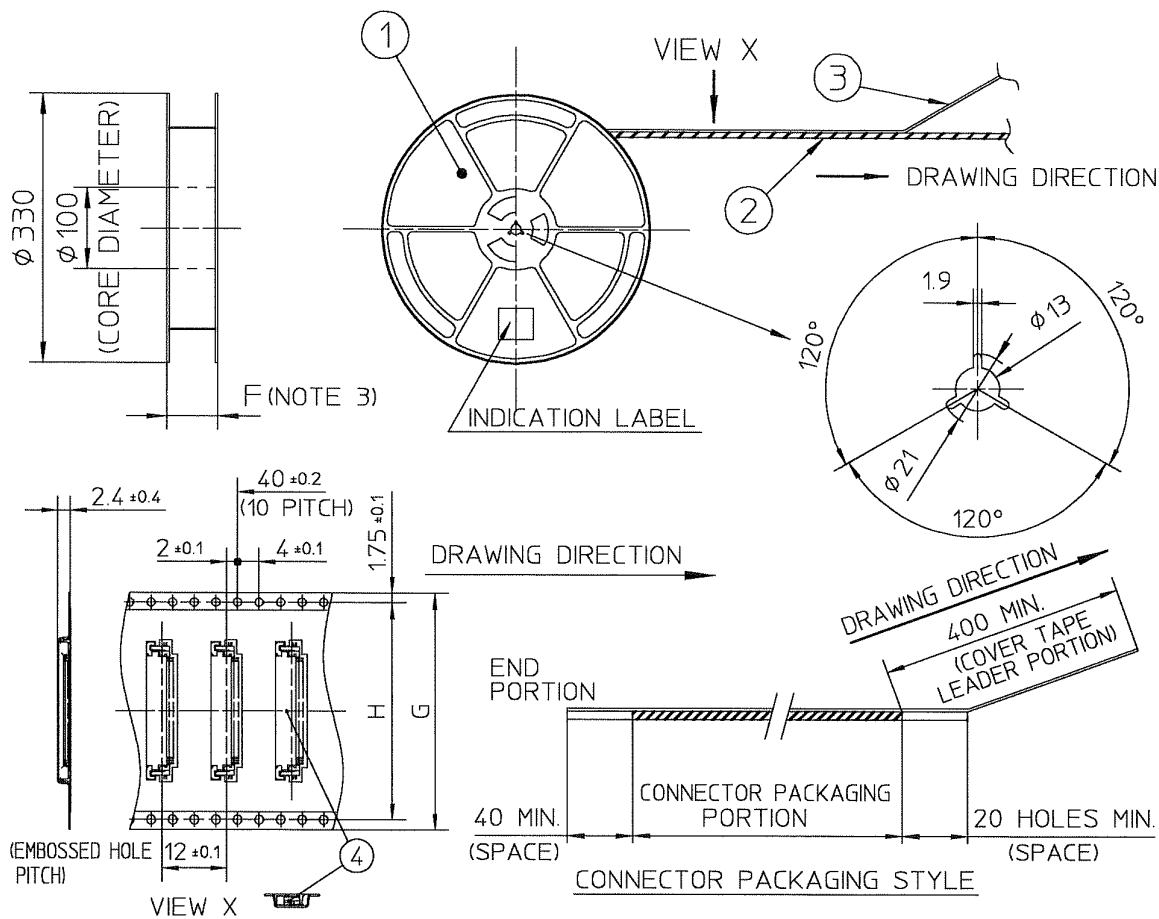

PT. NO.	PARTS NAME	CAT. NO.	MATERIAL	Q'TY	NOTE
1	REEL	—	POLYSTYRENE	1	COLOR : BLACK
2	PLASTIC (EMBOSS) TAPE	—	A-PET	—	COLOR : TRANSPARENCY
3	COVER	—	POLYESTER	—	COLOR : TRANSPARENCY
4	CONNECTOR	SFV_R-2STZ_LF	SEE ATTACHED DWG.	2500	LOWER CONTACT TYPE

NOTES

1. THIS IS PLASTIC TAPE PACKAGED CONNECTOR USED FOR FPC AND COPES WITH AUTOMATIC MOUNTING (SMT).
2. SEE JIS C 0806 (PACKING OF ELECTRONIC COMPONENTS ON CONTINUOUS TAPES (SURFACE MOUNTING DEVICES)) FOR SHAPE AND DIMENSIONS OF PLASTIC (EMBOSS) TAPE AND REEL.
3. F DIMENSION IS PORTION OF THE CORE.

mat'l. code		surface ISO 1302 ✓		tolerance ISO 406 ISO 1101		projection		product family 58EF	
ltr		ecn no		dr		date		title	
A		J06-0219		H.T		5/30/06		PLASTIC TAPE PACKAGED 0.5 mm CONTACT SPACING CONNECTOR (Cat. No. : SFV_R-2STZE5LF)	
		angles		linear		scale X		dwg no	
								sheet 1 of 1	
		dr		engr		chr		JSA 97164	
								A4	
		appd		S. Radwan		5/30/06		type Customer Drawing	
sheet index		revision		A				Rev. A	
		sheet		1					

form: A4 SC-SFV03 JSA97162



FCJconnect.com

Copyright FCI

RECOMMENDED CABLE (FPC)

n : NO. OF CONTACTS

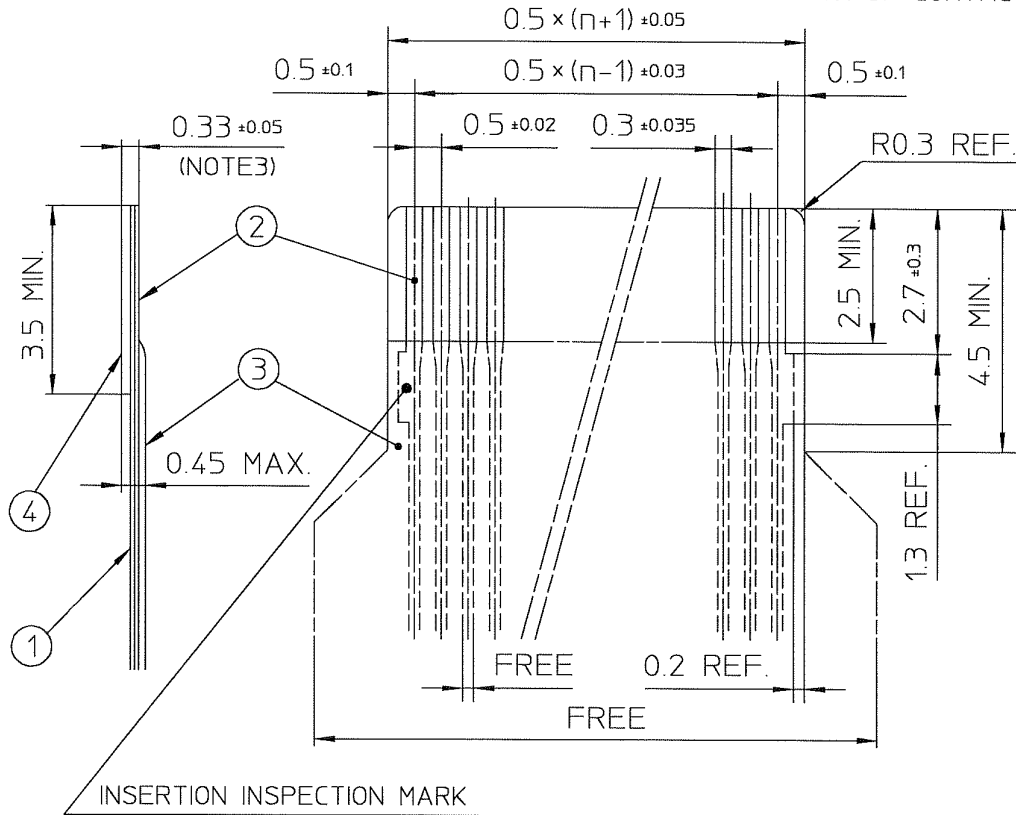

PT. NO.	PARTS NAME	MATERIAL	THICKNESS(μm)
1	BASE FILM	POLYIMIDE OR POLYESTER OR EQUAL	25
2	CONDUCTOR	COPPER FOIL(PLATING : SOLDER 1μm MIN.)	35
3	OVERLAY	POLYIMIDE OR POLYESTER OR EQUAL	—
4	SUPPORTING TAPE	POLYESTER OR POLYIMIDE OR EQUAL	188

NOTES

1. NO BURR AT EACH PORTION.
2. NO PEELING IN COMMON USE.
3. TOTAL THICKNESS LIMIT OF EACH MATERIAL (INCLUDING ADHESIVE AGENT) IS SPECIFIED.

mat'l. code				surface ISO 1302 ✓		tolerance ISO 406 ISO 1101		projection		product family 58EF	
1   —   M.H.   '94/12/8				tolerances unless otherwise specified		angles linear		title		RECOMMENDED CABLE	
AA   J03-0196   H.T.   '03/5/1								scale X		(Cat. No. : SFV__R-1/2ST__)	
AB   J06-0372   H.T.   '06/9/7								dwg no		sheet 1 of 1	
				dr   <i>[Signature]</i>   9/9/06		engr   <i>[Signature]</i>   9/9/06		chr   <i>[Signature]</i>   9/8/06		JSA 92456	
				appd   <i>[Signature]</i>   9/11/06		FCJ		type Product Customer Drawing		size A4	
sheet index		revision sheet		AB 1						Rev. AB	

SC-SFV01 JSA92450 Form: A4

1

2



FCconnect.com

Copyright FCI



RECOMMENDED CABLE (FFC)

n : NO. OF CONTACTS

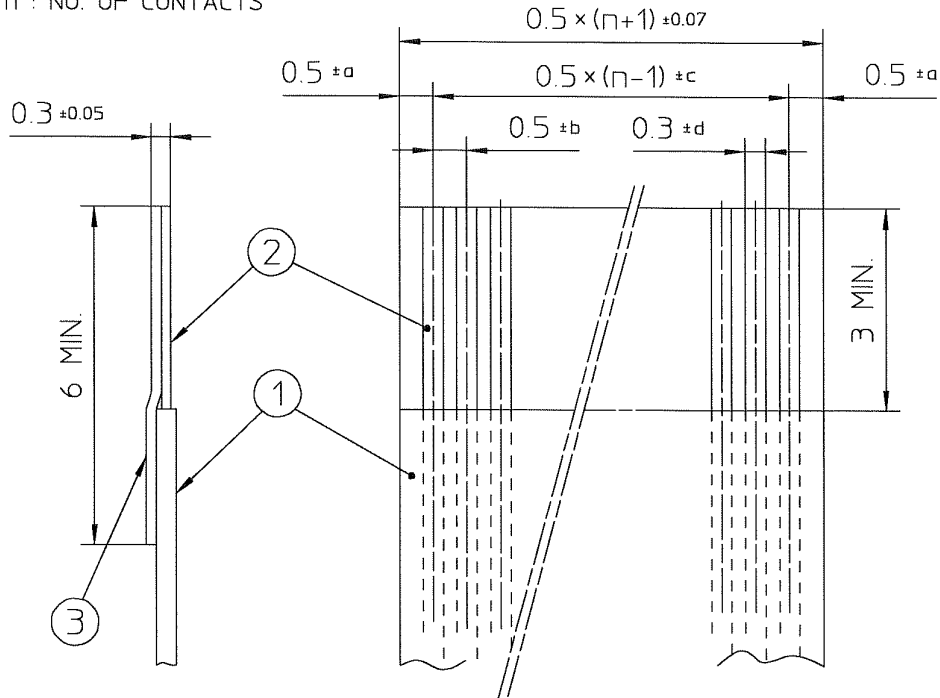

KIND OF FFC (NOTE3)	DIMENSIONAL TOLERANCE			
	a	b	c	d
1	±0.07	±0.04	±0.05	±0.02
2	±0.1	±0.03	±0.03	±0.025

PT. NO.	PARTS NAME	MATERIAL	NOTE
1	INSULATOR	FLAME RESISTING POLYESTER OR EQUAL	_____
2	CONDUCTOR	COPPER FOIL:THICKNESS 35 OR 50 μm	PLATING :TIN OR SOLDER 1μm MIN.
3	SUPPORTING TAPE	FLAME RESISTING POLYESTER OR EQUAL	_____

NOTES

1. NO BURR AT EACH PORTION.
2. NO PEELING IN COMMON USE.
3. EITHER KIND1 OR KIND2 OF FFC CAN ACCEPT DIMENSIONAL TOLERANCE a,b,c AND d.

mat'l. code				surface ISO 1302 <input checked="" type="checkbox"/>	tolerance ISO 406 ISO 1101	projection	product family 58EF	
ltr	ecn no	dr	date	tolerances unless otherwise specified			title	
1	—	S.I	'93/9/9	angles	linear		RECOMMENDED CABLE (Cat. No. : SFV__R-1/2ST__)	
AA	J03-0196	H.T	'03/5/1			scale X	sheet 1 of 1	
AB	J06-0372	H.T	'06/9/17	dr	<i>[Signature]</i> 11/27/06		sheet 1 of 1	
AC	J06-0499	H.T	'06/11/27	enr	<i>[Signature]</i> 11/27/06		JSA 92457	
				chr	<i>[Signature]</i> 11/27/06		A4	
				appd	<i>[Signature]</i> 11/28/06		type Product Customer Drawing	
sheet index	revision	AC						Rev. AC
	sheet	1						

SC-SFV01 JSA92450 form: A4



FCIconnect.com

Copyright FCI