

CAT. NO. & DIMENSIONS

NO. OF CONTACTS (n)	CAT. NO.	DIMENSIONS (NOTE2)			
		A ± 0.2	B ± 0.2	C ± 0.2	D ± 0.1
4	SFW4R-1/2ST__	9.8	8.6	3.0	5.3
5	SFW5R-1/2ST__	10.8	9.6	4.0	6.3
6	SFW6R-1/2ST__	11.8	10.6	5.0	7.3
7	SFW7R-1/2ST__	12.8	11.6	6.0	8.3
8	SFW8R-1/2ST__	13.8	12.6	7.0	9.3
9	SFW9R-1/2ST__	14.8	13.6	8.0	10.3
10	SFW10R-1/2ST__	15.8	14.6	9.0	11.3
11	SFW11R-1/2ST__	16.8	15.6	10.0	12.3
12	SFW12R-1/2ST__	17.8	16.6	11.0	13.3
13	SFW13R-1/2ST__	18.8	17.6	12.0	14.3
14	SFW14R-1/2ST__	19.8	18.6	13.0	15.3
15	SFW15R-1/2ST__	20.8	19.6	14.0	16.3
16	SFW16R-1/2ST__	21.8	20.6	15.0	17.3
17	SFW17R-1/2ST__	22.8	21.6	16.0	18.3
18	SFW18R-1/2ST__	23.8	22.6	17.0	19.3
19	SFW19R-1/2ST__	24.8	23.6	18.0	20.3
20	SFW20R-1/2ST__	25.8	24.6	19.0	21.3
21	SFW21R-1/2ST__	26.8	25.6	20.0	22.3
22	SFW22R-1/2ST__	27.8	26.6	21.0	23.3
23	SFW23R-1/2ST__	28.8	27.6	22.0	24.3
24	SFW24R-1/2ST__	29.8	28.6	23.0	25.3
25	SFW25R-1/2ST__	30.8	29.6	24.0	26.3
26	SFW26R-1/2ST__	31.8	30.6	25.0	27.3
27	SFW27R-1/2ST__	32.8	31.6	26.0	28.3
28	SFW28R-1/2ST__	33.8	32.6	27.0	29.3
29	SFW29R-1/2ST__	34.8	33.6	28.0	30.3
30	SFW30R-1/2ST__	35.8	34.6	29.0	31.3

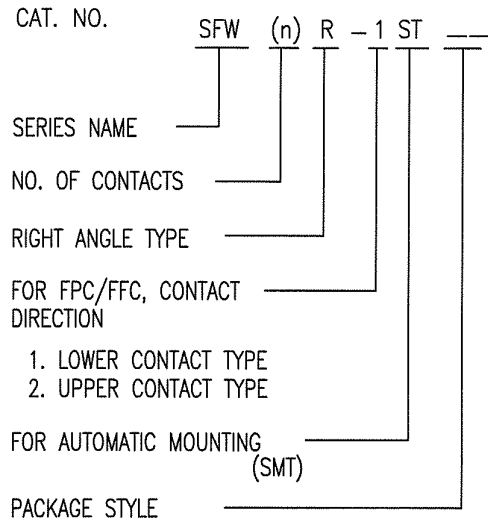

NOTES

1. THIS PRODUCT IS THE CONNECTOR USED FOR FPC/FFC AND COPES WITH AUTOMATIC MOUNTING (SMT).
2. SEE PART DRAWINGS FOR DIMENSIONS A~D.

mat'l. code -		surface 58 / tolerance ISO 1302 ✓ / ISO 406 / ISO 1101		projection	product family 58RF	CODE JP
ltr	ecn no	dr	date	tolerances unless otherwise specified		title CAT NO. TABLE FOR 1mm SPACING SMT CONNECTOR (Cat. No. SFW__R-1/2ST__)
4	Redrawn & 27, 28 position added	A.U	'93-7-20	angles	Linear	
A	J06-0398	H.T	9/26/06	mm		
B	J09-0358	M.Y	2009-10-5	scale X		dwg no JSA 91598 sheet 1 of 1 size A4
sheet index SC-SFW01 form: A4		revision B	sheet 1			type Product Customer Drawing

JSA91599 91600 91604 91605

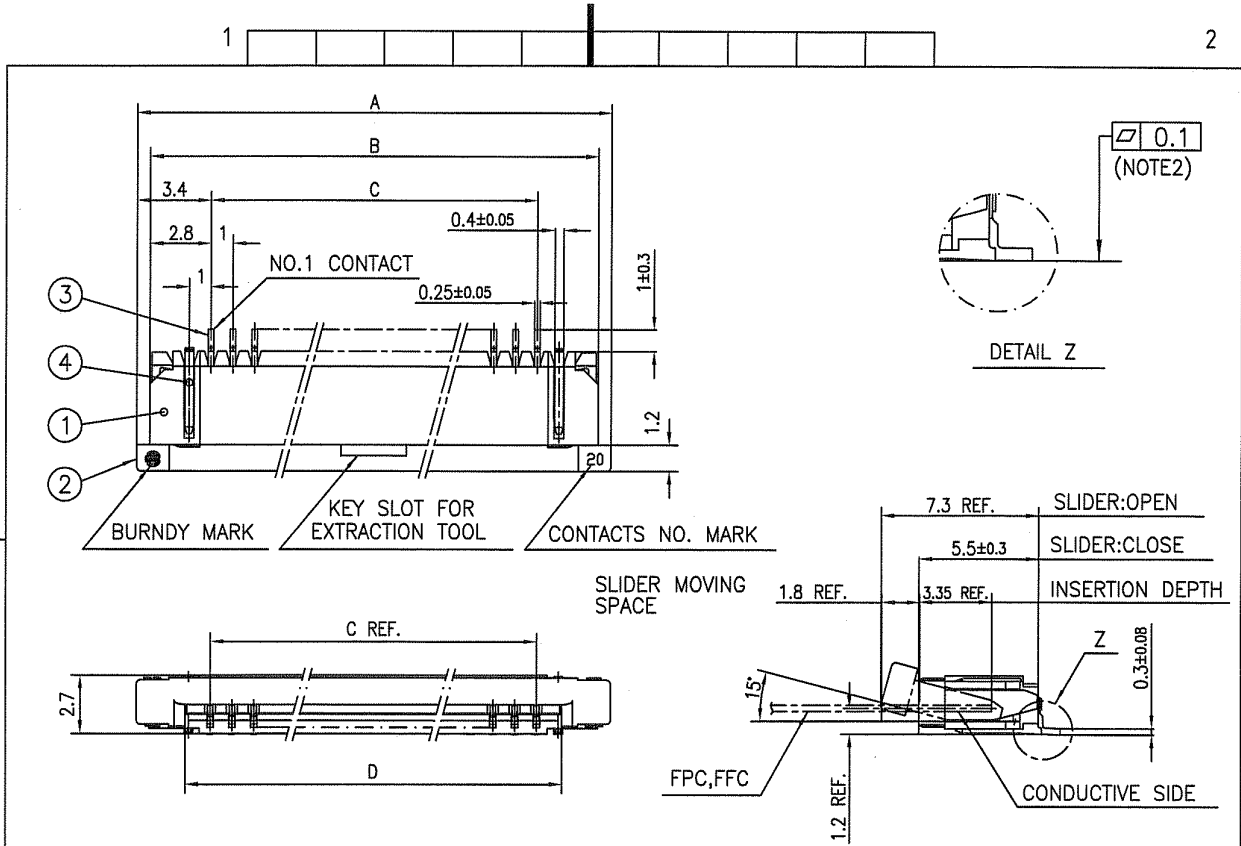

PT. NO.	PARTS NAME	MATERIAL	Q'TY	NOTE
1	HOUSING	PPS RESIN GLASS	1	COLOR:BROWN
2	SLIDER	REINFORCED (UL94V-0)	1	COLOR:BLACK
3	CONTACT	PHOSPHOR BRONZE	n	PLATING:TIN ALLOY
4	MOUNTING PLATE		2	

n : NO. OF CONTACTS

RECOMMENDED PC BOARD LAYOUT  
(COMPONENT SIDE)

BASIC PATTERN  
NO.1 CONTACT  
POSITION

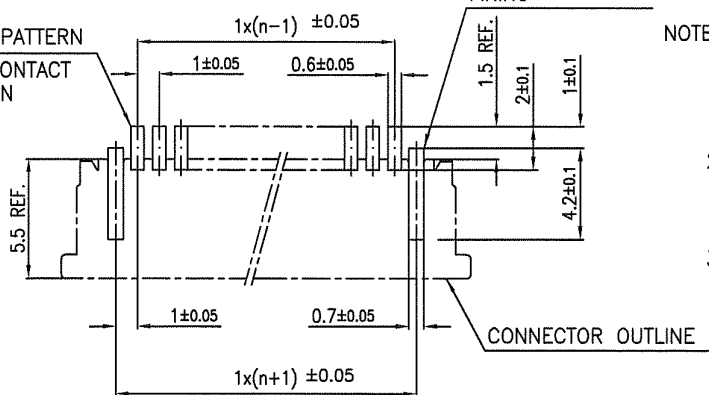

NOTES

1. THIS PRODUCT IS THE CONNECTOR USED FOR FPC/FFC AND COPES WITH AUTOMATIC MOUNTING (SMT).
2. FLATNESS FOR CONTACT TERMINAL HOUSING MUST BE WITHIN TOLERANCE IN Z PORTION DETAILED DRAWING.
3. THIS PRODUCT IS LOWER CONTACT TYPE CONNECTOR.

mat'l. code				surface 58	tolerance ISO 406	projection	product family 58RF	CODE JP
ltr ecn no dr date				ISO 1302	ISO 1101	mm	title 1mm SPACING SMT CONNECTOR (Cat. No. SFW__R-1ST__)	
AA	J04-0180	H.T	7/2/04	tolerances unless otherwise specified				
AB	J06-0398	H.T	9/26/06	angles	linear	scale X	dwg no sheet 1 of 1 size JSA 91599 A4	
AC	J09-0358	M.Y	2009-10-5					
				dr	M. YAMASHITA	2009-10-5	type Product Customer Drawing	
				enr	M. YAMASHITA	2009-10-5		
				chr	D. Williams	2009-10-6		
				appd	P. Anderson	2009-10-6		
sheet index	revision sheet	AC	1					Rev. AC

SC-SFW01 JSA91598  
form: A4

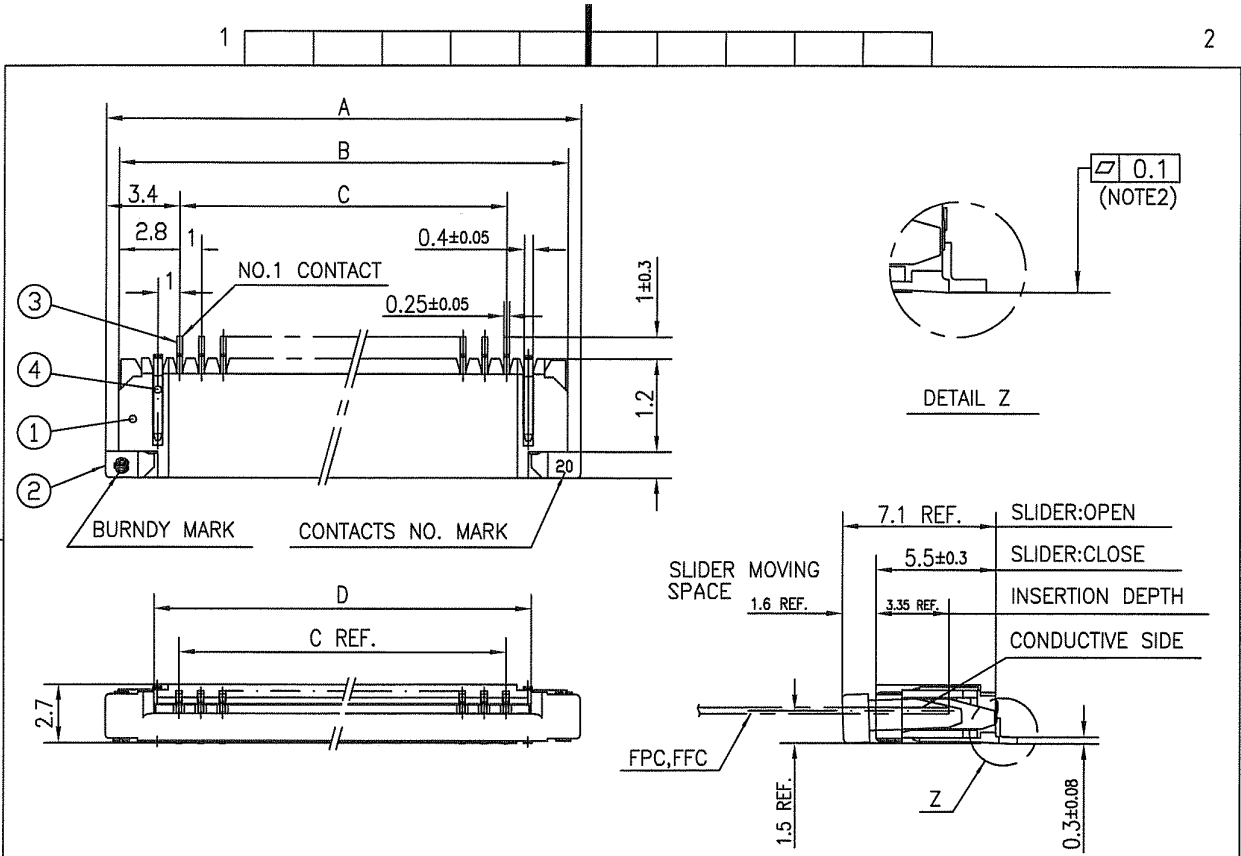

PT. NO.	PARTS NAME	MATERIAL	Q'TY	NOTE
1	HOUSING	PPS RESIN GLASS REINFORCED (UL94V-0)	1	COLOR:BROWN
2	SLIDER		1	COLOR:BLACK
3	CONTACT	PHOSPHOR BRONZE	n	PLATING:TIN ALLOY
4	MOUNTING PLATE		2	

n : NO. OF CONTACTS

RECOMMENDED PC BOARD LAYOUT (COMPONENT SIDE)

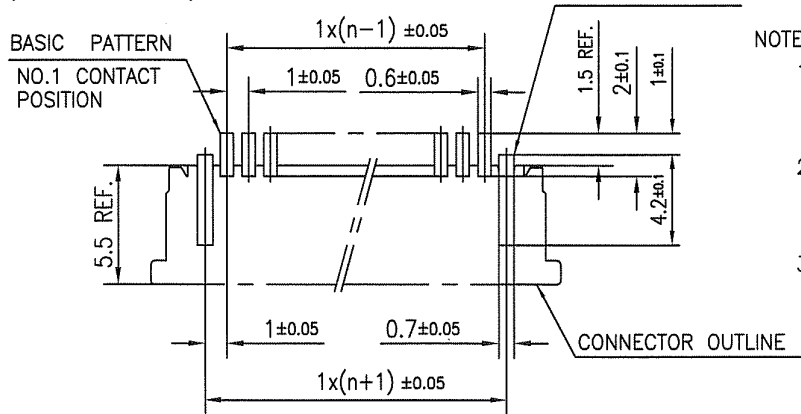

NOTES

1. THIS PRODUCT IS THE CONNECTOR USED FOR FPC/FFC AND COPES WITH AUTOMATIC MOUNTING (SMT).
2. FLATNESS FOR CONTACT TERMINAL HOUSING MUST BE WITHIN TOLERANCE IN Z PORTION DETAILED DRAWING.
3. THIS PRODUCT IS UPPER CONTACT TYPE CONNECTOR.

mat'l. code				surface 58	tolerance ISO 406	projection	product family 58RF	CODE JP	
ltr ecn no dr date				ISO 1302	ISO 1101	mm	title		
AA	J04-0180	H.T	7/2/04	tolerances unless otherwise specified			1mm SPACING SMT CONNECTOR		
AB	J06-0398	H.T	9/26/06	angles	linear	scale X	(Cat. No. SFW__R-2ST__)		
AC	J09-0358	M.Y	2009-10-5				dwg no sheet 1 of 1 size		
				dr	M. S. YAMASHITA		2009-10-5	JSA 91600 A4	
				engr	M. S. YAMASHITA		2009-10-5		
				chr	S. Nakamura		2009-10-6		
				appd	S. Nakamura	2009-10-6	type Product Customer Drawing		
sheet index	revision	AC	sheet 1					Rev. AC	

SC-SFW01 JSA91598 form: A4

CAT. NO. & DIMENSIONS

NO. OF CONTACTS (n)	CAT. NO. (NOTE2)	DIMENSIONS (NOTE3)		
		E ± 5	F ± 0.3	G ± 0.1
4	SFW4R-1/2STE1	20.4	16	—
5	SFW5R-1/2STE1	28.4	24	—
6	SFW6R-1/2STE1	28.4	24	—
7	SFW7R-1/2STE1	28.4	24	—
8	SFW8R-1/2STE1	28.4	24	—
9	SFW9R-1/2STE1	28.4	24	—
10	SFW10R-1/2STE1	28.4	24	—
11	SFW11R-1/2STE1	28.4	24	—
12	SFW12R-1/2STE1	28.4	24	—
13	SFW13R-1/2STE1	36.4	32	28.4
14	SFW14R-1/2STE1	36.4	32	28.4
15	SFW15R-1/2STE1	36.4	32	28.4
16	SFW16R-1/2STE1	36.4	32	28.4
17	SFW17R-1/2STE1	48.4	44	40.4
18	SFW18R-1/2STE1	48.4	44	40.4
19	SFW19R-1/2STE1	48.4	44	40.4
20	SFW20R-1/2STE1	48.4	44	40.4
21	SFW21R-1/2STE1	48.4	44	40.4
22	SFW22R-1/2STE1	48.4	44	40.4
23	SFW23R-1/2STE1	48.4	44	40.4
24	SFW24R-1/2STE1	48.4	44	40.4
25	SFW25R-1/2STE1	48.4	44	40.4
26	SFW26R-1/2STE1	48.4	44	40.4
27	SFW27R-1/2STE1	48.4	44	40.4
28	SFW28R-1/2STE1	60.4	56	52.4
29	SFW29R-1/2STE1	60.4	56	52.4
30	SFW30R-1/2STE1	60.4	56	52.4

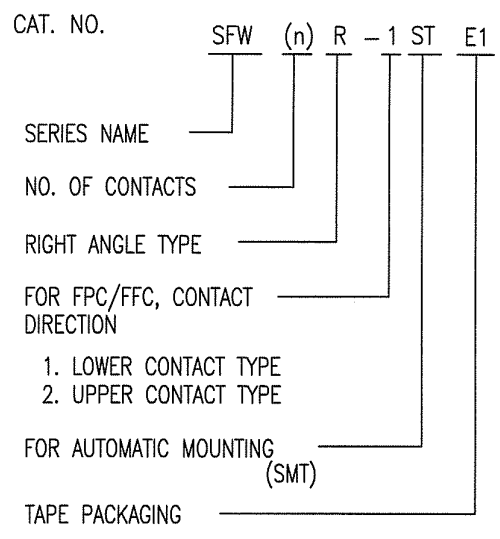

NOTES

1. THIS PRODUCT IS THE CONNECTOR USED FOR FPC/FFC AND COPES WITH AUTOMATIC MOUNTING (SMT).
2. THIS CATALOG NO. INDICATES PLASTIC TAPE PACKAGED CONNECTOR.
3. SEE PART DRAWINGS FOR DIMENSIONS E~G.

mat'l. code		surface 58 / tolerance ISO 1302 ✓ ISO 406 ISO 1101		projection	product family 58RF	CODE JP
ltr	ecn no	dr	date	tolerances unless otherwise specified	mm	title CAT NO. TABLE FOR PLASTIC TAPE PACKAGED 1mm SPACING SMT CONNECTOR (Cat. No. SFW__R-1/2STE1)
4	REVISION & 27/29 POSITIONS ADDED J06-0398	A.U	7/20/93			
A	J06-0398	H.T	9/26/06	angles	scale X	dwg no JSA 91601 sheet 1 of 1 size A4
B	J09-0358	M.Y	2009-10-5	Linear		
sheet index		revision	B	dr	FCJ	type Product Customer Drawing
sheet		1		enr		
				chr		
				appd		

SC-SFW01 JSA91602 91603 91598 91599 91600 91604 91605 1



FCIconnect.com

Copyright FCI.

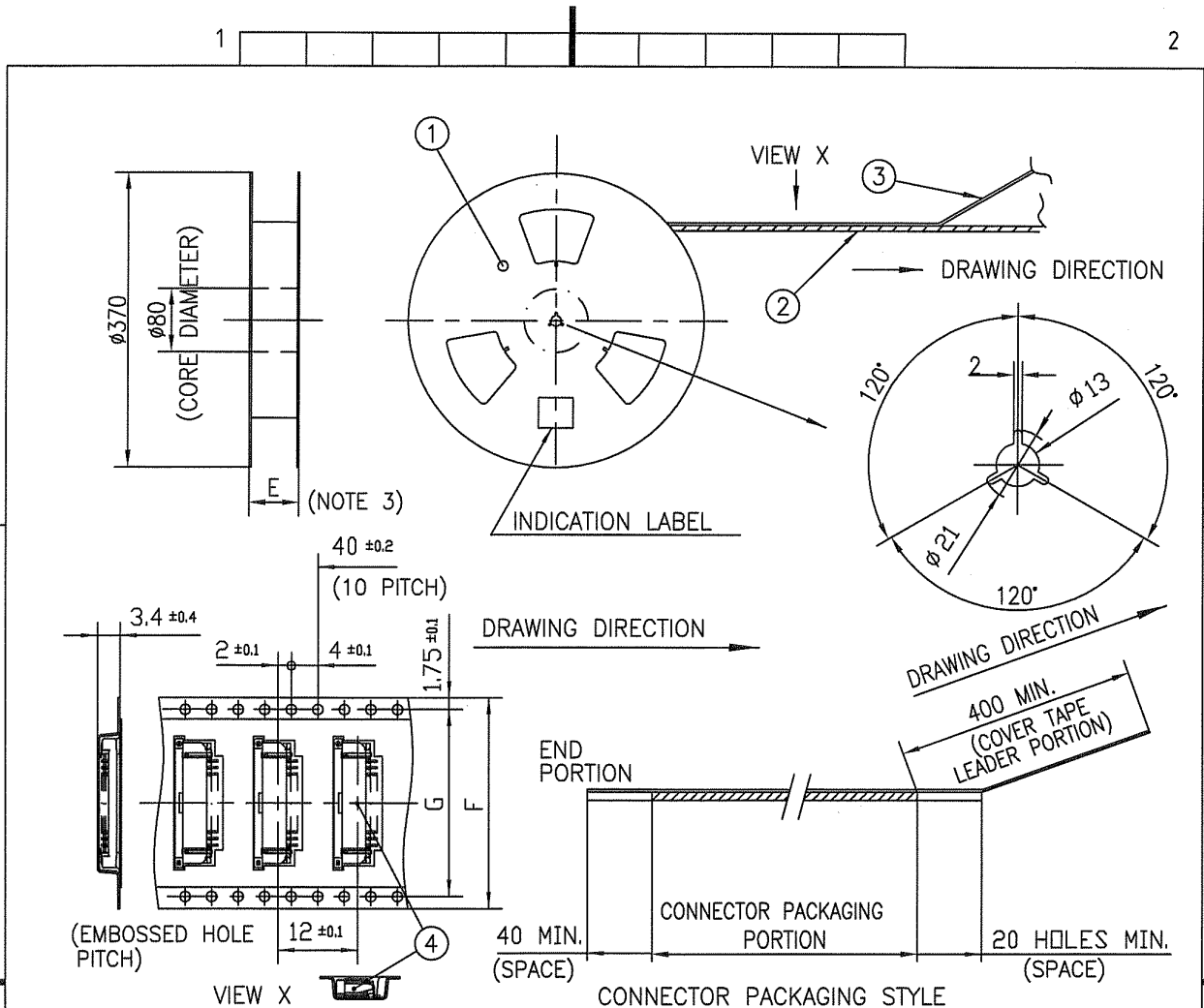

PT. NO.	PARTS NAME	CAT. NO.	MATERIAL	Q'TY	NOTE
1	REEL	_____	CARDBOARD	1	COLOR:WHITE
2	PLASTIC (EMBOSS) TAPE	_____	PET	_____	COLOR:TRANSPARENCY
3	COVER	_____	POLYESTER	_____	COLOR:TRANSPARENCY
4	SURFLOK CONNECTOR	SFW__R-1ST__	SEE ATTACHED DWG.	2000	LOWER CONTACT TYPE

NOTES

- THIS IS PLASTIC TAPE PACKAGED CONNECTOR USED FOR FPC/FFC AND COPES WITH AUTOMATIC MOUNTING (SMT).
- SEE JIS C 0806 (PACKING OF ELECTRONIC COMPONENTS ON CONTINUOUS TAPES (SURFACE MOUNTING DEVICES)) FOR SHAPE AND DIMENSIONS OF PLASTIC (EMBOSS) TAPE AND REEL.
- E DIMENSION IS PORTION OF THE CORE.

mat'l. code				surface ISO 1302	tolerance ISO 406 ISO 1101	projection	product family 58RF	CODE JP
ltr	ecn no	dr	date	tolerances unless otherwise specified		mm	title PLASTIC TAPE PACKAGED 1mm SPACING SMT CONNECTOR (Cat. No. SFW__R-1STE1)	
1	—	M.H	4/21/'94	angles	±5			
2	—	M.K	6/27/'96	linear		scale X	dwg no sheet 1 of 1 size JSA 91602 A4	
A	J06-0398	H.T	9/26/'06	±5'				
B	J09-0358	M.Y	2009-10-5	dr	H. YAMASHITA 2009-10-5	FCJ	type Product Customer Drawing	
				enr	M. YAMASHITA 2009-10-5			
				chr	S. Witala 2009-10-6			
				appd	D. Chelara 2009-10-6			
sheet index	revision B	sheet 1						Rev. B

SC-SFW01 JSA91601 form: A4



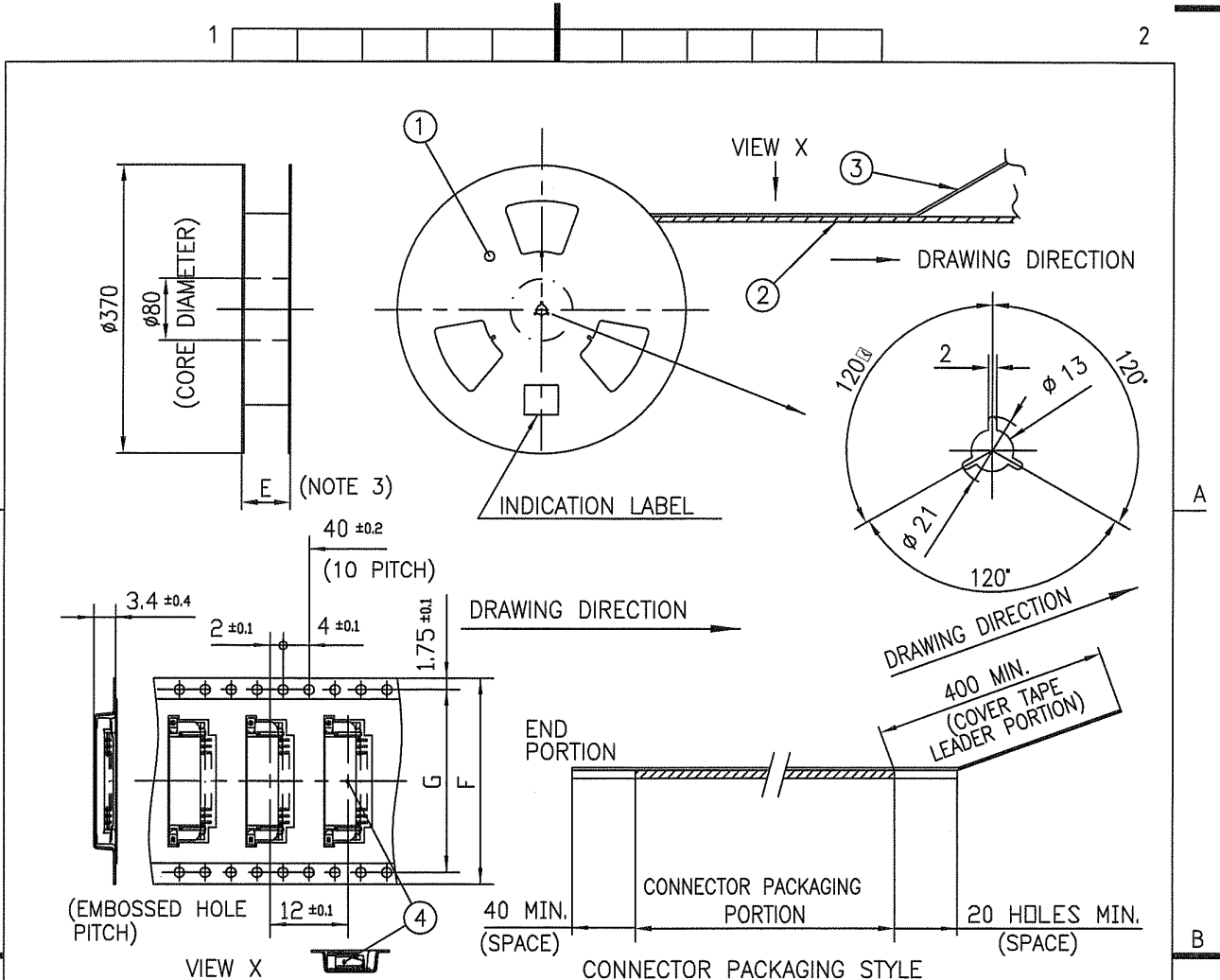

PT. NO.	PARTS NAME	CAT. NO.	MATERIAL	Q'TY	NOTE
1	REEL	_____	CARDBOARD	1	COLOR:WHITE
2	PLASTIC (EMBOSS) TAPE	_____	PET	_____	COLOR:TRANSPARENCY
3	COVER	_____	POLYESTER	_____	COLOR:TRANSPARENCY
4	SURFLOK CONNECTOR	SFW__R-2ST__	SEE ATTACHED DWG.	2000	UPPER CONTACT TYPE

NOTES

- THIS IS PLASTIC TAPE PACKAGED CONNECTOR USED FOR FPC/FFC AND COPES WITH AUTOMATIC MOUNTING (SMT).
- SEE JIS C 0806 (PACKING OF ELECTRONIC COMPONENTS ON CONTINUOUS TAPES (SURFACE MOUNTING DEVICES)) FOR SHAPE AND DIMENSIONS OF PLASTIC (EMBOSS) TAPE AND REEL.
- E DIMENSION IS PORTION OF THE CORE.

mat'l. code		surface ISO 1302 <input checked="" type="checkbox"/>		tolerance ISO 406 ISO 1101		projection		product family 58RF		CODE JP	
ltr		ecn no		dr		date		tolerances unless otherwise specified		title	
1		---		M.H		4/21/'94		angles		PLASTIC TAPE PACKAGED	
2		---		M.K		6/27/'96		linear		1mm SPACING SMT CONNECTOR	
A		J06-0398		H.T		9/26/'06		±5°		(Cat. No. SFW__R-2STE1)	
B		J09-0358		M.Y		2009-10-5		scale X		dwg no	
				dr		M. YAMASHITA 2009-10-5		mm		sheet 1 of 1	
				enr		M. YAMASHITA 2009-10-5		←		size	
				chr		S. Watanabe 2009-10-6		FCJ		JSA 91603	
				appd		S. Watanabe 2009-10-6				A4	
sheet		revision		B				type		Product Customer Drawing	
index		sheet		1						Rev. B	

SC-SFW01 JSA91601 form: A4

RECOMMENDED CABLE (FFC)

n : NO. OF CONDUCTOR

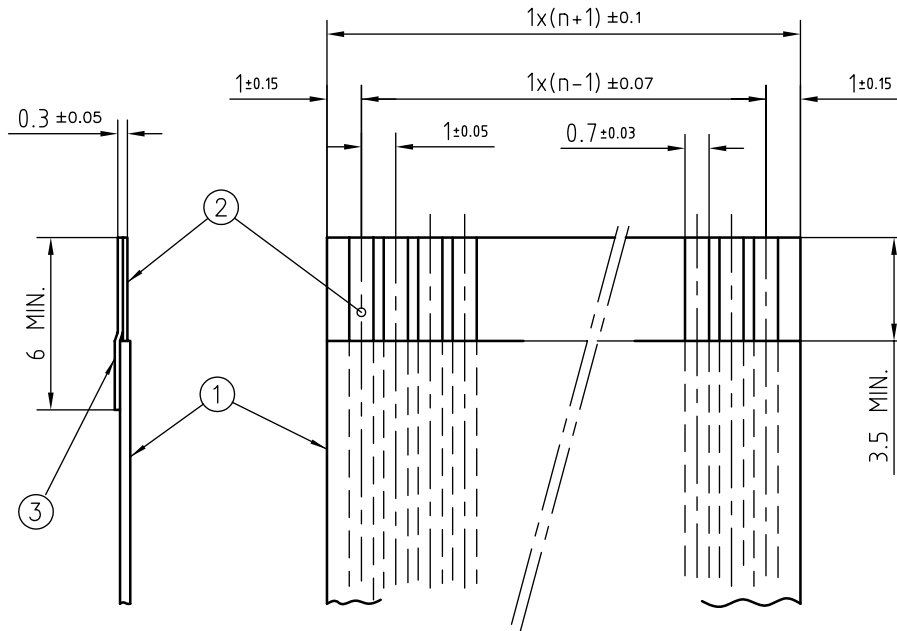

PT. NO.	PARTS NAME	MATERIAL	NOTE
1	INSULATOR	FLAME RESISTING POLYESTER OR EQUAL	_____
2	CONDUCTOR	COPPER FOIL	PLATING:TIN OR SOLDER 1um MIN.
3	SUPPORTING TAPE	FLAME RESISTING POLYESTER OR EQUAL	_____

NOTES

1. NO BURR AT EACH PORTION.
2. NO PEELING IN COMMON USE.
3. A SYMBOL WILL BE NEXT TO ANY DIMENSION, VIEW, OR NOTE WHICH HAS BEEN MODIFIED WITH THE CURRENT DRAWING REVISION.

mat'l. code		surface 58 ISO 1302		tolerance ISO 406 ISO 1101		projection 		product family 58RF		CODE JP	
ltr	ecn no	dr	date	tolerances unless otherwise specified		mm		title RECOMMENDED CABLE (Cat. No. SFW__R-1/2_____)			
AA	J05-0055	H.T	05-02-04	angles	linear	mm		dwg no sheet 1 of 1 size JSA 91604 A4			
AB	J06-0398	H.T	06-09-26			scale					
AC	S08-0276	DGOH	08-08-22					type Product Customer Drawing			
sheet index		revision	AC							Rev. AC	

form: A4

This document is the property of and embodies CONFIDENTIAL and PROPRIETARY information of FCI. No part of the information shown on this document may be used in any way or disclosed to others without the written consent of FCI. Copyright FCI.



FCIconnect.com

RECOMMENDED CABLE (FPC)

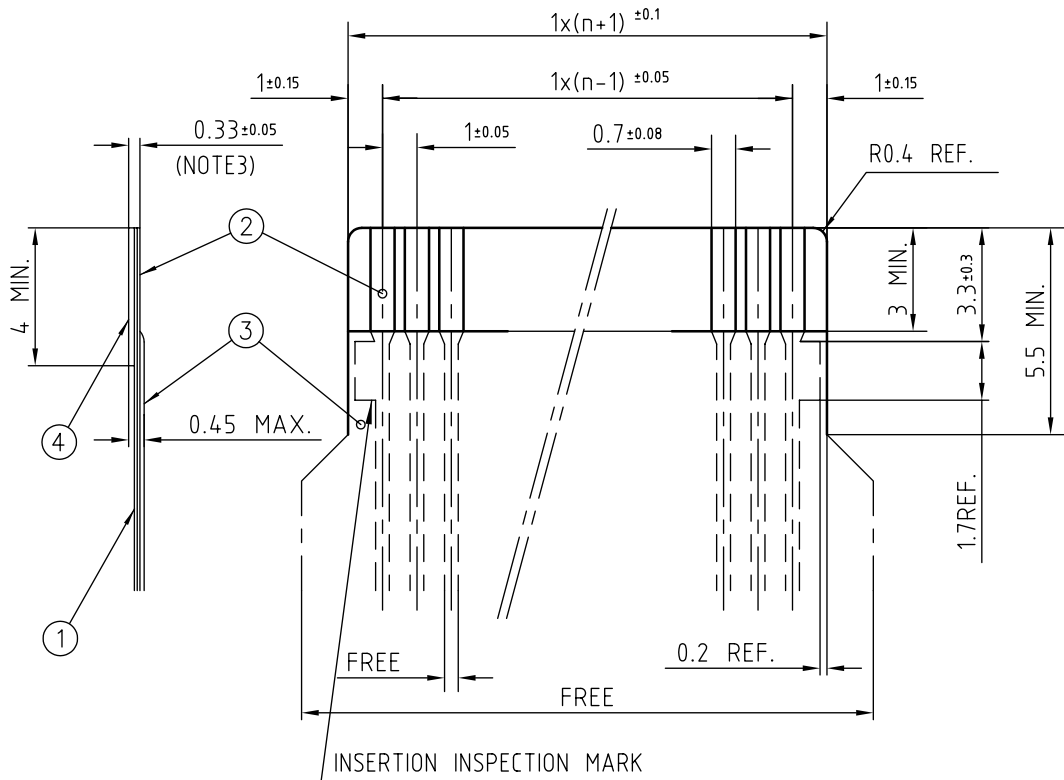

n : NO. OF CONDUCTOR



PT. NO.	PARTS NAME	MATERIAL	THICKNESS (um)
1	BASE FILM	POLYIMIDE OR POLYESTER OR EQUAL	25
2	CONDUCTOR	COPPER FOIL(PLATING:SOLDER 1um MIN.)	35
3	OVERLAY	POLYIMIDE OR POLYESTER OR EQUAL	—
4	SUPPORTING TAPE	POLYESTER OR POLYIMIDE OR EQUAL	188

NOTES

1. NO BURR AT EACH PORTION.
2. NO PEELING IN COMMON USE.
3. TOTAL THICKNESS LIMIT OF EACH MATERIAL (INCLUDING ADHESIVE AGENT) IS SPECIFIED.
4. A  SYMBOL WILL BE NEXT TO ANY DIMENSION, VIEW, OR NOTE WHICH HAS BEEN MODIFIED WITH THE CURRENT DRAWING REVISION.

mat'l. code		surface 58 ISO 1302		tolerance ISO 406 ISO 1101		projection 		product family 58RF		CODE JP	
ltr	ecn no	dr	date	tolerances unless otherwise specified		mm		title RECOMMENDED CABLE (Cat. No. SFW__R-1/2__)			
AA	J05-0055	H.T	05-02-04	angles	linear	mm		dwg no JSA 91605 sheet 1 of 1 size A4 type Product Customer Drawing			
AB	J06-0398	H.T	06-09-26			scale $\times$					
AC	S08-0276	DGOH	08-08-22								
			dr	H. TAKAKURA	06-09-26			sheet 1 of 1 size A4			
			enr	H. TAKAKURA	06-09-26						
			chr	DENNIS GOH	08-08-22						
			appd	JOEY NG	08-08-22						
sheet index	revision	AC	1								Rev. AC

form: A4

1

2

PDM: Rev:AC

STATUS: Released

Printed: Jul 07, 2009

This document is the property of and embodies CONFIDENTIAL and PROPRIETARY information of FCI. No part of the information shown on this document may be used in any way or disclosed to others without the written consent of FCI. Copyright FCI.



FCIconnect.com

