



FCIconnect.com

Copyright FCI

List of "SFV__R-1/2STAE1LF" customer document

DOCUMENT NO.	LIST
SC-SFV06	SPEC.
JSA96245	CAT.NO.TABLE FOR 0.5mm CONTACT SPACING CONNECTOR (SFV__R-1/2STA_LF)
JSA96246	CONNECTOR USED FOR FPC/FFC WITH 0.5mm CONTACT SPACING (SFV__R-1STA_LF)
JSA96247	CONNECTOR USED FOR FPC/FFC WITH 0.5mm CONTACT SPACING (SFV__R-2STA_LF)
JSA96248	CAT.NO.TABLE FOR PLASTIC TAPE PACKAGED 0.5mm CONTACT SPACING CONNECTOR (SFV__R-1/2STAE1LF)
JSA96249	PLASTIC TAPE PACKAGED 0.5mm CONTACT SPACING CONNECTOR (SFV__R-1STAE1LF)
JSA96250	PLASTIC TAPE PACKAGED 0.5mm CONTACT SPACING CONNECTOR (SFV__R-2STAE1LF)
JSA96004	RECOMMENDED CABLE (FPC) (SFV__R-1/2STA_...)
JSA97202	RECOMMENDED CABLE (FFC) (SFV__R-1/2ST_...)
BJM-SFV101	HANDLING PROCEDURES

mat'l. code				surface ISO 1302 <input checked="" type="checkbox"/>		tolerance ISO 406 ISO 1101		projection 		product family 58EF			
ltr	ecn no	dr	date	tolerances unless otherwise specified						title 0.5mm SPACING FPC CONNECTOR DOCUMENT LIST (Cat. No. : SFV__R-1/2STAE1LF)			
A	J04-0454	H.T	'05/2/7	angles		linear		scale χ		dwg no JSA 96244 sheet 1 of 1 size A4 type Product Customer Drawing			
B	J06-0372	H.T	'06/9/7	dr		11/27/06							
C	J06-0499	H.T	'06/11/27	enr		11/27/06							
				chr		11/27/06							
				appd		S. (Name) 11/28/06							
sheet index	revision sheet	C	1							Rev. C			

form: A4

1

2

CAT. NO. & DIMENSIONS

NO. OF CONTACTS (n)	CAT. NO.	DIMENSIONS (NOTE2)			
		A ± 0.2	B ± 0.2	C ± 0.1	D ± 0.1
4	SFV4R-1/2STA__LF	7.5	5.9	1.5	2.7
5	SFV5R-1/2STA__LF	8.0	6.4	2.0	3.2
6	SFV6R-1/2STA__LF	8.5	6.9	2.5	3.7
7	SFV7R-1/2STA__LF	9.0	7.4	3.0	4.2
8	SFV8R-1/2STA__LF	9.5	7.9	3.5	4.7
9	SFV9R-1/2STA__LF	10.0	8.4	4.0	5.2
10	SFV10R-1/2STA__LF	10.5	8.9	4.5	5.7
11	SFV11R-1/2STA__LF	11.0	9.4	5.0	6.2
12	SFV12R-1/2STA__LF	11.5	9.9	5.5	6.7
13	SFV13R-1/2STA__LF	12.0	10.4	6.0	7.2
14	SFV14R-1/2STA__LF	12.5	10.9	6.5	7.7
15	SFV15R-1/2STA__LF	13.0	11.4	7.0	8.2
16	SFV16R-1/2STA__LF	13.5	11.9	7.5	8.7
17	SFV17R-1/2STA__LF	14.0	12.4	8.0	9.2
18	SFV18R-1/2STA__LF	14.5	12.9	8.5	9.7
19	SFV19R-1/2STA__LF	15.0	13.4	9.0	10.2
20	SFV20R-1/2STA__LF	15.5	13.9	9.5	10.7
21	SFV21R-1/2STA__LF	16.0	14.4	10.0	11.2
22	SFV22R-1/2STA__LF	16.5	14.9	10.5	11.7
23	SFV23R-1/2STA__LF	17.0	15.4	11.0	12.2
24	SFV24R-1/2STA__LF	17.5	15.9	11.5	12.7
25	SFV25R-1/2STA__LF	18.0	16.4	12.0	13.2
26	SFV26R-1/2STA__LF	18.5	16.9	12.5	13.7
27	SFV27R-1/2STA__LF	19.0	17.4	13.0	14.2
28	SFV28R-1/2STA__LF	19.5	17.9	13.5	14.7
29	SFV29R-1/2STA__LF	20.0	18.4	14.0	15.2
30	SFV30R-1/2STA__LF	20.5	18.9	14.5	15.7
31	SFV31R-1/2STA__LF	21.0	19.4	15.0	16.2
32	SFV32R-1/2STA__LF	21.5	19.9	15.5	16.7
33	SFV33R-1/2STA__LF	22.0	20.4	16.0	17.2
34	SFV34R-1/2STA__LF	22.5	20.9	16.5	17.7
35	SFV35R-1/2STA__LF	23.0	21.4	17.0	18.2

CAT. NO. SFV (n) R - 1 ST A -- LF

SERIES NAME

NO. OF CONTACTS

RIGHT ANGLE TYPE

FOR FPC/FFC, CONTACT DIRECTION

1. LOWER CONTACT TYPE
2. UPPER CONTACT TYPE

FOR AUTOMATIC MOUNTING (SMT)

GOLD PLATING

PACKAGE STYLE

LEAD FREE

NOTES

- THIS PRODUCT IS THE CONNECTOR USED FOR FPC AND COPES WITH AUTOMATIC MOUNTING (SMT).
- SEE PART DRAWINGS FOR DIMENSIONS A-D.



FCIconnect.com

Copyright FCI

mat'l. code				surface ISO 1302 ✓		tolerance ISO 406 ISO 1101		projection		product family 58EF			
ltr ecn no dr date				tolerances unless otherwise specified				title		CAT. NO. TABLE FOR 0.5 mm CONTACT SPACING CONNECTOR (Cat. No. : SFV__R-1/2STA__LF)			
A J04-0454 H.T '05/2/7				angles linear				scale X		dwg no JSA 96245 sheet 1 of 1 size A4			
B J06-0372 H.T '06/9/7				dr engr chr appd				FCI		type Product Customer Drawing			
sheet index		revision sheet		B 1								Rev. B	

SC-SFV06 JSA96246, 96247, 96248, 96004 form: A4

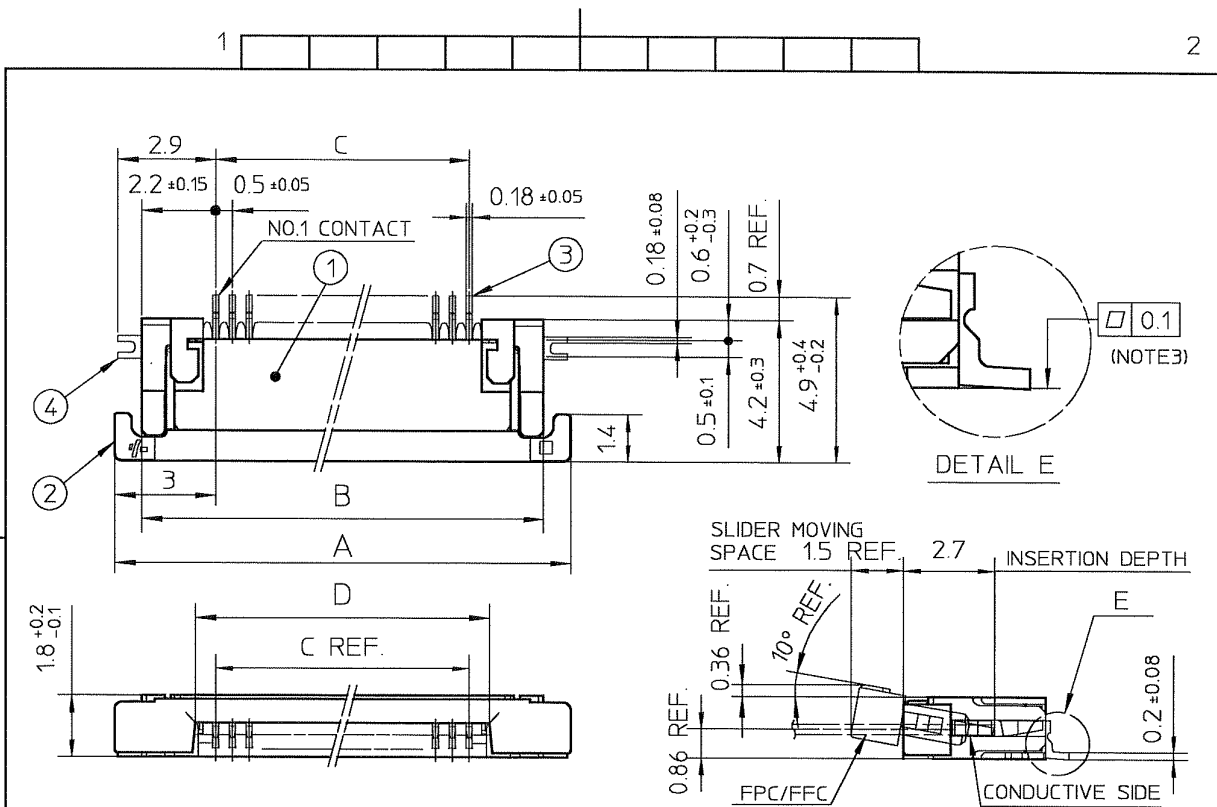

PT. NO.	PARTS NAME	MATERIAL	Q'TY	NOTE
1	HOUSING	POLYAMIDE RESIN GLASS REINFORCED (UL94V-0)	1	COLOR :BLACK
2	SLIDER	PPS RESIN GLASS REINFORCED (UL94V-0)	1	COLOR :BROWN
3	CONTACT	PHOSPHOR BRONZE	n	PLATING : CONTACT AREA GOLD TERMINAL AREA TIN
4	MOUNTING PLATE		2	PLATING :LEAD FREE

RECOMMENDED PC BOARD LAYOUT
(COMPONENT SIDE)

PATTERN FOR MOUNTING PLATE
FIXING

n : NO. OF CONTACTS

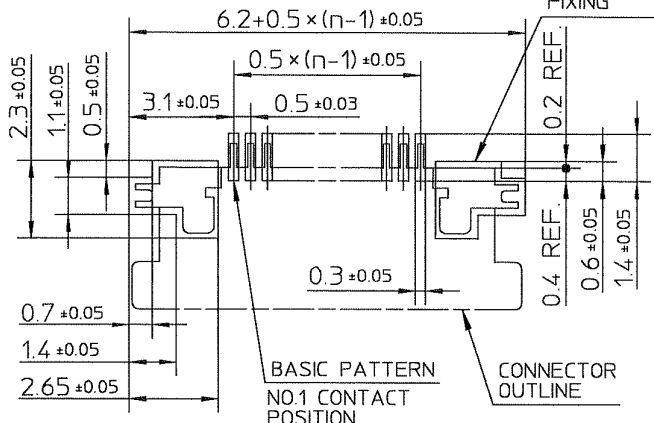

NOTES

- 1.THIS PRODUCT IS THE CONNECTOR USED FOR FPC AND COPES WITH AUTOMATIC MOUNTING (SMT).
- 2.THIS PRODUCT IS LOWER CONTACT TYPE CONNECTOR.
- 3.FLATNESS OF CONTACT TERMINAL AND MOUNTING PLATE MUST BE WITHIN TOLERANCE IN E PORTION DETAILED DRAWING.
- 4.THIS PRODUCT MEETS EUROPEAN UNION DIRECTIVES AND OTHER COUNTRY REGULATIONS AS DESCRIBED IN GS-22-008.
- 5.THE HOUSING WILL WITHSTAND EXPOSURE TO 260°C PEAK TEMPERATURE FOR 10 SECONDS IN A REFLOW SOLDERING OVEN.

mat'l. code				surface ISO 1302		tolerance ISO 406 ISO 1101		projection		product family 58EF	
ltr ecn no dr date				tolerances unless otherwise specified		angles linear		title		CONNECTION USED FOR FPC WITH 0.5 mm CONTACT SPACING (Cat No. : SFV_R-1STA_LF)	
A J04-0454 H.T '05/2/17								scale		dwg no sheet 1 of 1 size	
B J05-0710 H.T '05/10/21								FCI		JSA 96246 A4	
C J06-0064 H.T '06/2/23										type Product Customer Drawing	
D J06-0372 H.T '06/9/17				dr 9/17/06		engr 9/17/06					
				chr 9/8/06		appd 9/11/06					
sheet index		revision sheet		D 1						Rev. D	

SC-SFV06 JSA96245 Form: A4



FCIconnect.com

Copyright FCI

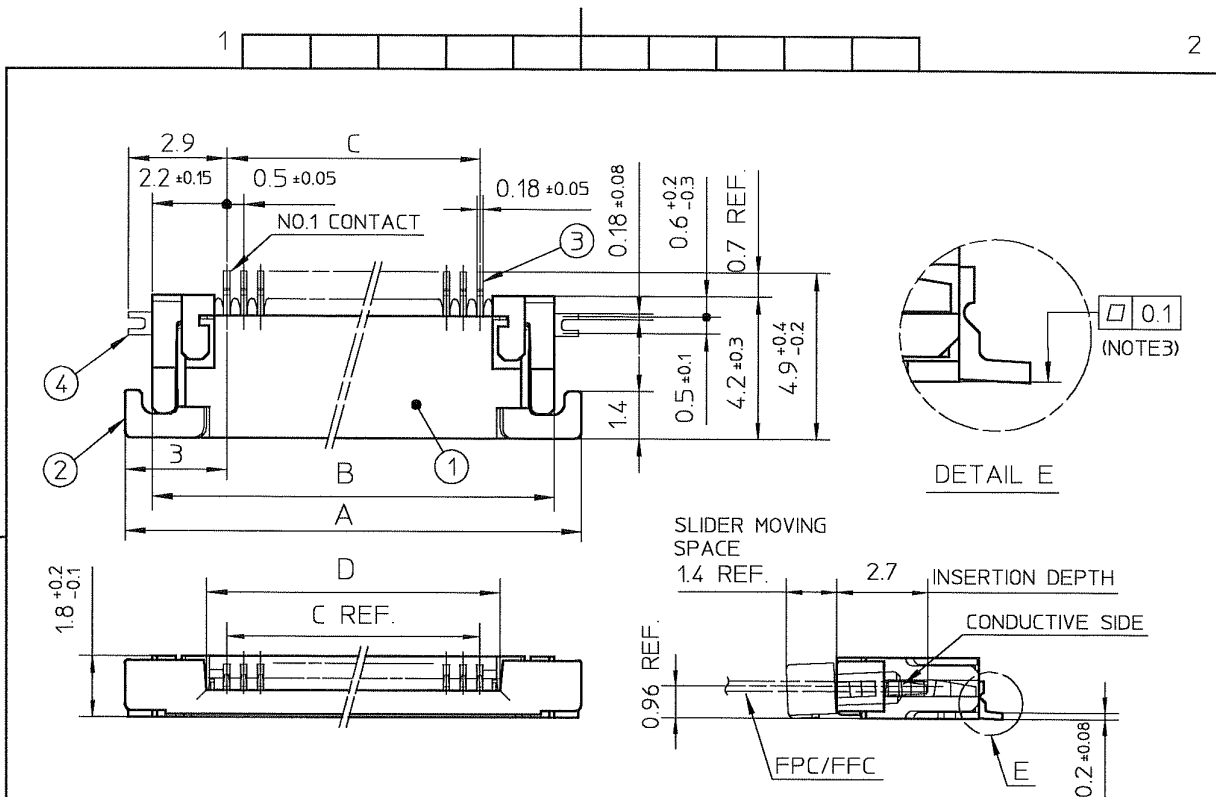

PT. NO.	PARTS NAME	MATERIAL	Q'TY	NOTE
1	HOUSING	POLYAMIDE RESIN GLASS REINFORCED (UL94V-0)	1	COLOR : BLACK
2	SLIDER	PPS RESIN GLASS REINFORCED (UL94V-0)	1	COLOR : BROWN
3	CONTACT	PHOSPHOR BRONZE	n	PLATING : CONTACT AREA GOLD TERMINAL AREA TIN
4	MOUNTING PLATE		2	PLATING : LEAD FREE

RECOMMENDED PC BOARD LAYOUT
(COMPONENT SIDE)

PATTERN FOR MOUNTING PLATE
FIXING

n : NO. OF CONTACTS

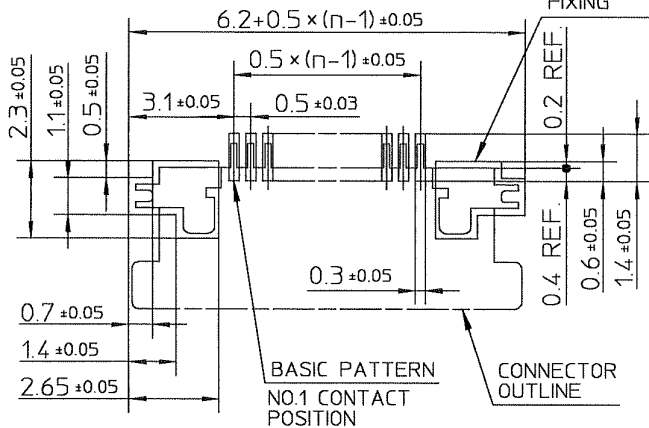

NOTES

1. THIS PRODUCT IS THE CONNECTOR USED FOR FPC AND COPE WITH AUTOMATIC MOUNTING (SMT).
2. THIS PRODUCT IS UPPER CONTACT TYPE CONNECTOR.
3. FLATNESS OF CONTACT TERMINAL AND MOUNTING PLATE MUST BE WITHIN TOLERANCE IN E PORTION DETAILED DRAWING.
4. THIS PRODUCT MEETS EUROPEAN UNION DIRECTIVES AND OTHER COUNTRY REGULATIONS AS DESCRIBED IN GS-22-008.
5. THE HOUSING WILL WITHSTAND EXPOSURE TO 260°C PEAK TEMPERATURE FOR 10 SECONDS IN A REFLOW SOLDERING OVEN.

mat'l. code		surface ISO 1302 ✓		tolerance ISO 406 ISO 1101		projection		product family 58EF	
ltr	ecn no	dr	date	tolerances unless otherwise specified		title		CONNECTION USED FOR FPC WITH 0.5 mm CONTACT SPACING (Cat. No. : SFV__R-2STA__LF)	
A	J04-0454	H.T	'05/2/17	angles	linear	±0.2	scale X	dwg no sheet 1 of 1 size	
B	J05-0710	H.T	'05/10/21					JSA 96247 A4	
C	J06-0064	H.T	'06/2/23	dr		9/7/06		type Product Customer Drawing	
D	J06-0372	H.T	'06/9/17	engr		9/7/06		Rev. D	
sheet index		revision	D	chr		9/8/06		Rev. D	
sheet		1		appd		9/8/06			

SC-SFV06 JSA96245 form: A4

CAT. NO. & DIMENSIONS

NO. OF CONTACTS (n)	CAT. NO.	DIMENSIONS (NOTE3)		
		F ± 5	G ± 0.3	H ± 0.1
4	SFV4R-1/2STAE1LF	20.4	16	—
5	SFV5R-1/2STAE1LF	20.4	16	—
6	SFV6R-1/2STAE1LF	20.4	16	—
7	SFV7R-1/2STAE1LF	28.4	24	—
8	SFV8R-1/2STAE1LF	28.4	24	—
9	SFV9R-1/2STAE1LF	28.4	24	—
10	SFV10R-1/2STAE1LF	28.4	24	—
11	SFV11R-1/2STAE1LF	28.4	24	—
12	SFV12R-1/2STAE1LF	28.4	24	—
13	SFV13R-1/2STAE1LF	28.4	24	—
14	SFV14R-1/2STAE1LF	28.4	24	—
15	SFV15R-1/2STAE1LF	28.4	24	—
16	SFV16R-1/2STAE1LF	28.4	24	—
17	SFV17R-1/2STAE1LF	28.4	24	—
18	SFV18R-1/2STAE1LF	28.4	24	—
19	SFV19R-1/2STAE1LF	28.4	24	—
20	SFV20R-1/2STAE1LF	28.4	24	—
21	SFV21R-1/2STAE1LF	28.4	24	—
22	SFV22R-1/2STAE1LF	28.4	24	—
23	SFV23R-1/2STAE1LF	36.4	32	28.4
24	SFV24R-1/2STAE1LF	36.4	32	28.4
25	SFV25R-1/2STAE1LF	36.4	32	28.4
26	SFV26R-1/2STAE1LF	36.4	32	28.4
27	SFV27R-1/2STAE1LF	36.4	32	28.4
28	SFV28R-1/2STAE1LF	36.4	32	28.4
29	SFV29R-1/2STAE1LF	36.4	32	28.4
30	SFV30R-1/2STAE1LF	36.4	32	28.4
31	SFV31R-1/2STAE1LF	48.4	44	40.4
32	SFV32R-1/2STAE1LF	48.4	44	40.4
33	SFV33R-1/2STAE1LF	48.4	44	40.4
34	SFV34R-1/2STAE1LF	48.4	44	40.4
35	SFV35R-1/2STAE1LF	48.4	44	40.4

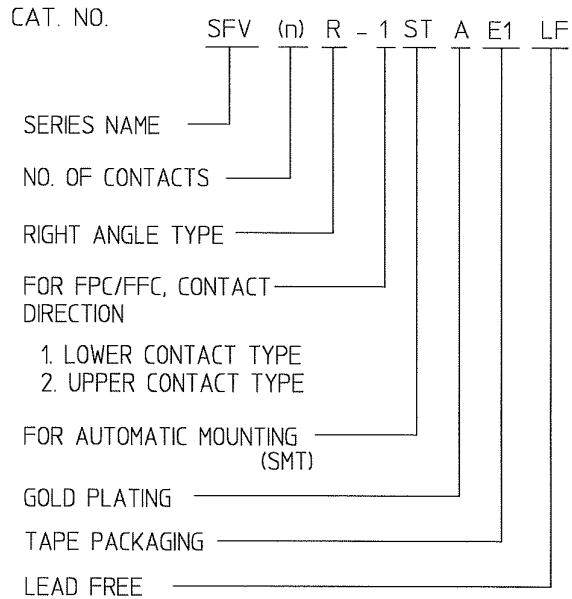

NOTES

- THIS PRODUCT IS THE CONNECTOR USED FOR FPC AND COPES WITH AUTOMATIC MOUNTING (SMT).
- THIS CATALOG NO. INDICATES PLASTIC TAPE PACKAGED CONNECTOR.
- SEE PART DRAWINGS FOR DIMENSIONS F-H.



FCIconnect.com

Copyright FCI

mat'l. code				surface ISO 1302 ✓		tolerance ISO 406 ISO 1101		projection		product family 58EF				
ltr	ecn no	dr	date	tolerances unless otherwise specified						title				
A	J04-0454	H.T	05/2/77	angles	linear	← →				CAT. NO. TABLE FOR PLASTIC TAPE PACKAGED 0.5 mm CONTACT SPACING CONNECTOR (Cat. No. : SFV__R-1/2STAE1LF)				
B	J06-0372	H.T	06/9/77			scale X				dwg no JSA 96248 sheet 1 of 1 size A4				
				dr	9/7/06						type Product Customer Drawing			
				engr	9/7/06									
				chr	9/8/06									
				appd	9/11/06									
sheet index	revision	B	1							Rev. B				

SC-SFV06 JSA96245 96249 96250 form: A4

1

2

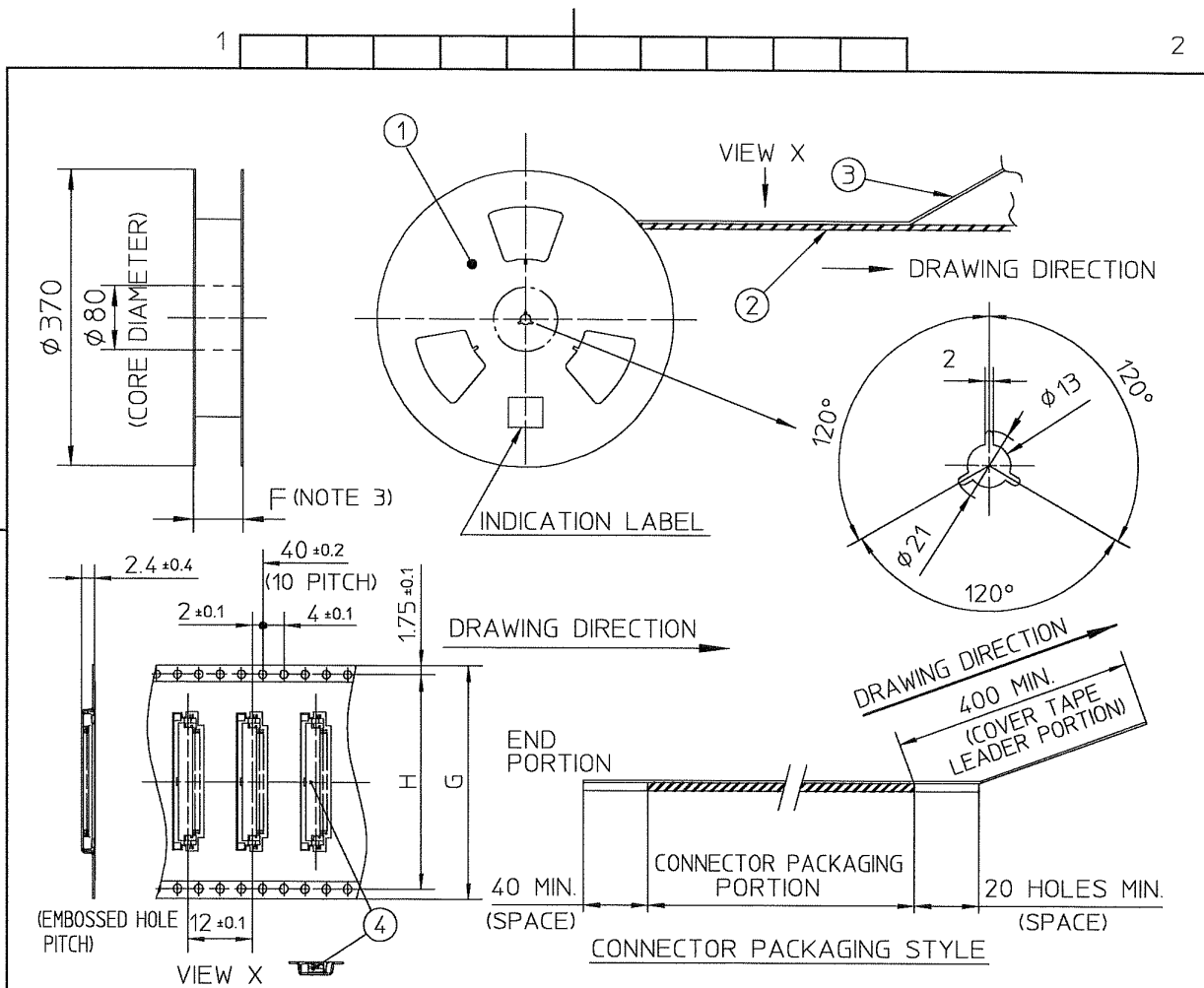

PT. NO.	PARTS NAME	CAT. NO.	MATERIAL	Q'TY	NOTE
1	REEL	—	CARDBOARD	1	COLOR : WHITE
2	PLASTIC (EMBOSS) TAPE	—	A-PET	—	COLOR : TRANSPARENCY
3	COVER	—	POLYESTER	—	COLOR : TRANSPARENCY
4	CONNECTOR	SFV__R-1STA__LF	SEE ATTACHED DWG.	3000	LOWER CONTACT TYPE

NOTES

- THIS IS PLASTIC TAPE PACKAGED CONNECTOR USED FOR FPC AND COPEs WITH AUTOMATIC MOUNTING (SMT).
- SEE JIS C 0806 (PACKING OF ELECTRONIC COMPONENTS ON CONTINUOUS TAPES (SURFACE MOUNTING DEVICES)) FOR SHAPE AND DIMENSIONS OF PLASTIC (EMBOSS) TAPE AND REEL.
- F DIMENSION IS PORTION OF THE CORE.

mat'l. code				surface ISO 1302 ✓	tolerance ISO 406 ISO 1101	projection	product family 58EF	
ltr	ecn no	dr	date	tolerances unless otherwise specified			title	
A	J04-0454	H.T	'05/2/7	angles	±5		PLASTIC TAPE PACKAGED 0.5 mm CONTACT SPACING CONNECTOR (Cat. No. : SFV__R-1STAE1LF)	
B	J06-0372	H.T	'06/9/7	linear		scale X	dwg no sheet 1 of 1 size	
				dr	<i>K. Shoji</i>	<i>9/7/06</i>	JSA 96249 A4	
				enr	<i>K. Shoji</i>	<i>9/7/06</i>	type Product Customer Drawing	
				chr	<i>R. Shoji</i>	<i>9/8/06</i>		
				appd	<i>S. Shoji</i>	<i>9/12/06</i>		
sheet index	revision	B						Rev. B
	sheet	1						

SC-SFV06 JSA96248 form: A4



FCJconnect.com

Copyright FCJ

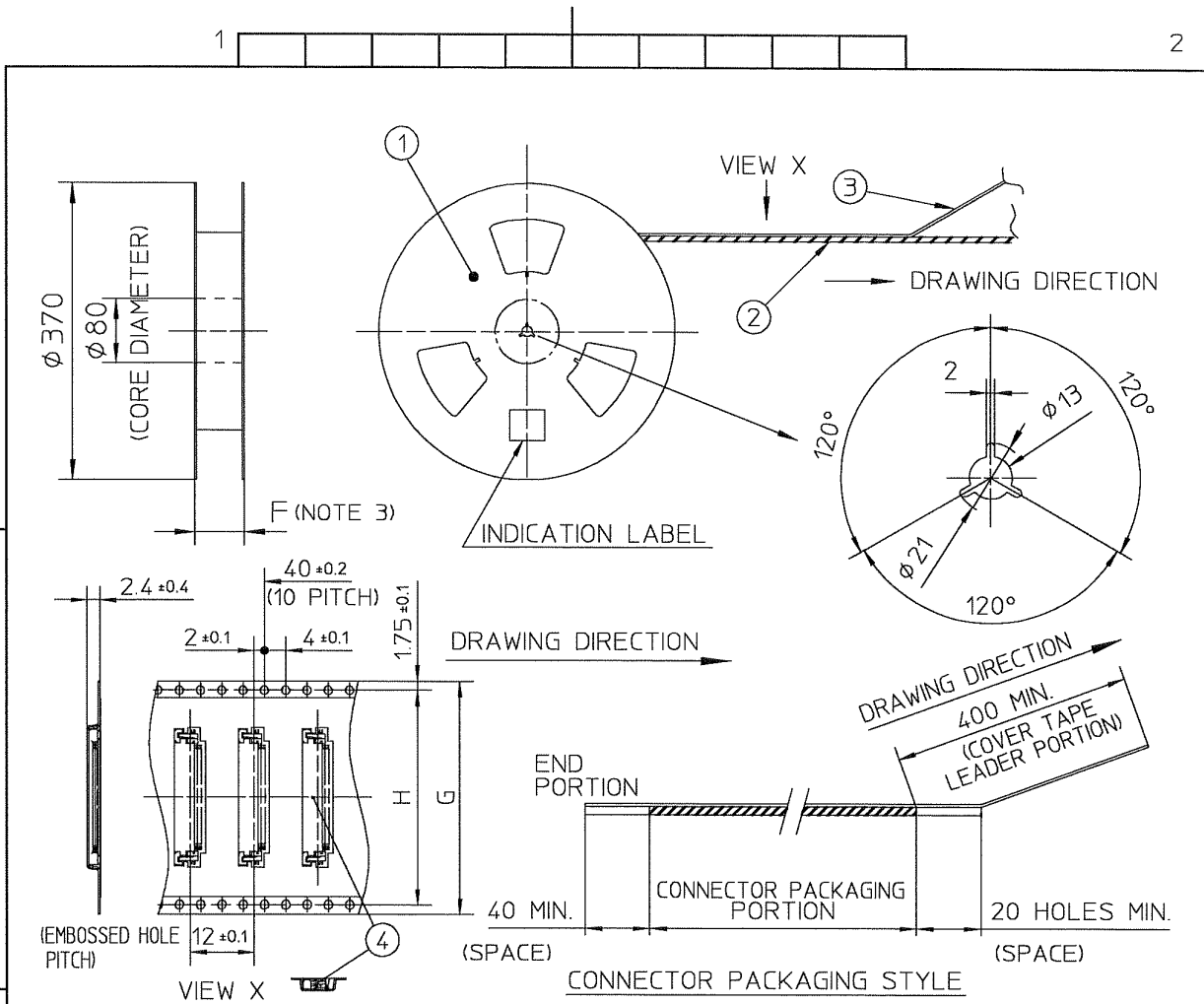

PT. NO.	PARTS NAME	CAT. NO.	MATERIAL	Q'TY	NOTE
1	REEL	_____	CARDBOARD	1	COLOR : WHITE
2	PLASTIC (EMBOSS) TAPE	_____	A-PET	—	COLOR : TRANSPARENCY
3	COVER	_____	POLYESTER	—	COLOR : TRANSPARENCY
4	CONNECTOR	SFV_R-2STA_LF	SEE ATTACHED DWG.	3000	UPPER CONTACT TYPE

NOTES

- THIS IS PLASTIC TAPE PACKAGED CONNECTOR USED FOR FPC AND COPEs WITH AUTOMATIC MOUNTING (SMT).
- SEE JIS C 0806 (PACKING OF ELECTRONIC COMPONENTS ON CONTINUOUS TAPES (SURFACE MOUNTING DEVICES)) FOR SHAPE AND DIMENSIONS OF PLASTIC (EMBOSS) TAPE AND REEL.
- F DIMENSION IS PORTION OF THE CORE.

mat'l. code				surface ISO 1302 ✓		tolerance ISO 406 ISO 1101		projection		product family 58EF	
ltr	ecn no	dr	date	tolerances unless otherwise specified				title		PLASTIC TAPE PACKAGED 0.5 mm CONTACT SPACING CONNECTOR (Cat. No. : SFV_R-2STAE1LF)	
A	J04-0454	H.T	'05/2/7	angles		±5		scale X		dwg no	
B	J06-0372	H.T	'06/9/7	linear		±5°		FCI		sheet 1 of 1	
				dr	9/7/06				JSA 96250		size
				enr	9/7/06						A4
				chr	9/8/06						
				appd	9/11/06						
sheet	revision	B								Rev.	
index	sheet	1								B	

SC-SFV06 JSA96248
form: A4



FCIconnect.com

Copyright FCI

RECOMMENDED CABLE (FPC)

n : NO. OF CONTACTS

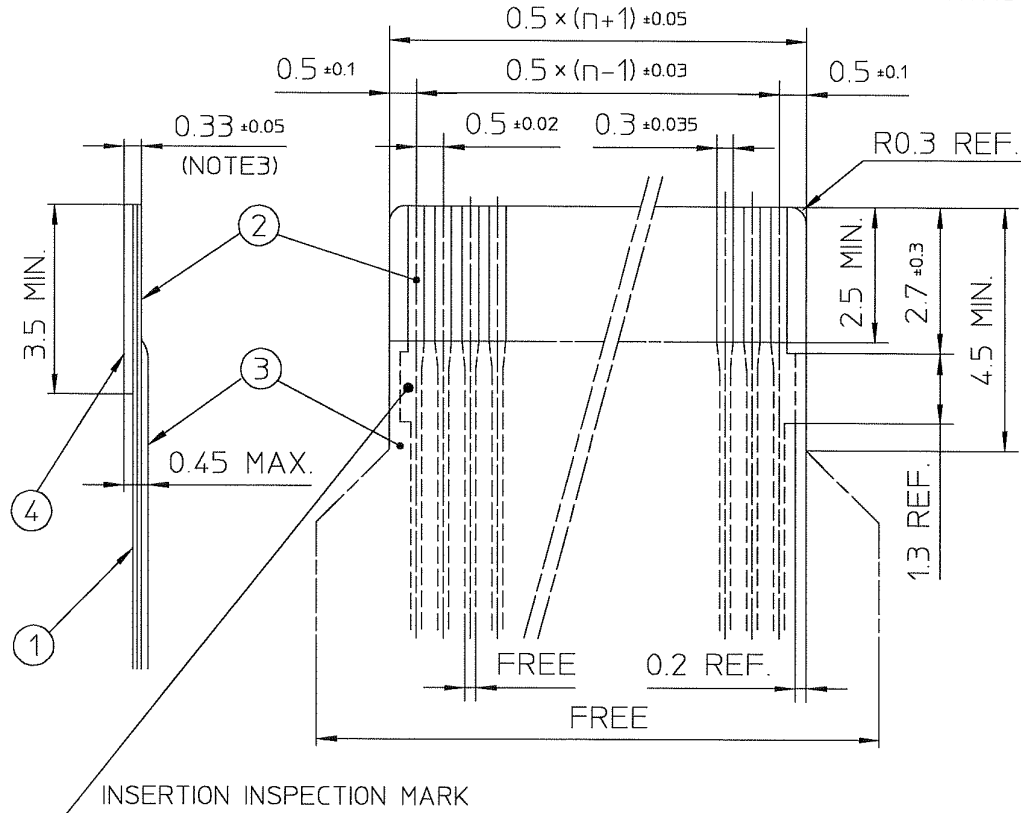

PT. NO.	PARTS NAME	MATERIAL	THICKNESS(μm)
1	BASE FILM	POLYIMIDE OR POLYESTER OR EQUAL	25
2	CONDUCTOR	COPPER FOIL(PLATING : GOLD)	35
3	OVERLAY	POLYIMIDE OR POLYESTER OR EQUAL	—
4	SUPPORTING TAPE	POLYESTER OR POLYIMIDE OR EQUAL	188

NOTES

1. NO BURR AT EACH PORTION.
2. NO PEELING IN COMMON USE.
3. TOTAL THICKNESS LIMIT OF EACH MATERIAL (INCLUDING ADHESIVE AGENT) IS SPECIFIED.

mat'l. code				surface ISO 1302 <input checked="" type="checkbox"/>		tolerance ISO 406 ISO 1101		projection		product family 58EF		
ltr	ecn no	dr	date	tolerances unless otherwise specified				title				
A	J04-0182	H.T.	'04/7/15	angles linear				RECOMMENDED CABLE (Cat. No. : SFV__R-1/2STA__)				
B	J06-0372	H.T.	'06/9/7									
				dr	<i>K. Shirota</i> 9/7/06				dwg no		sheet 1 of 1	size
				enr	<i>H. Shirota</i> 9/7/06				JSA 96004		A4	
				chr	<i>R. Shirota</i> 9/8/06				type Product Customer Drawing			
				appd	<i>S. Shirota</i> 9/11/06							
sheet index	revision	B										Rev. B

SC-SFV05 JSA95998 form: A4



FCIconnect.com

Copyright FCI

RECOMMENDED CABLE (FFC)

n : NO. OF CONTACTS

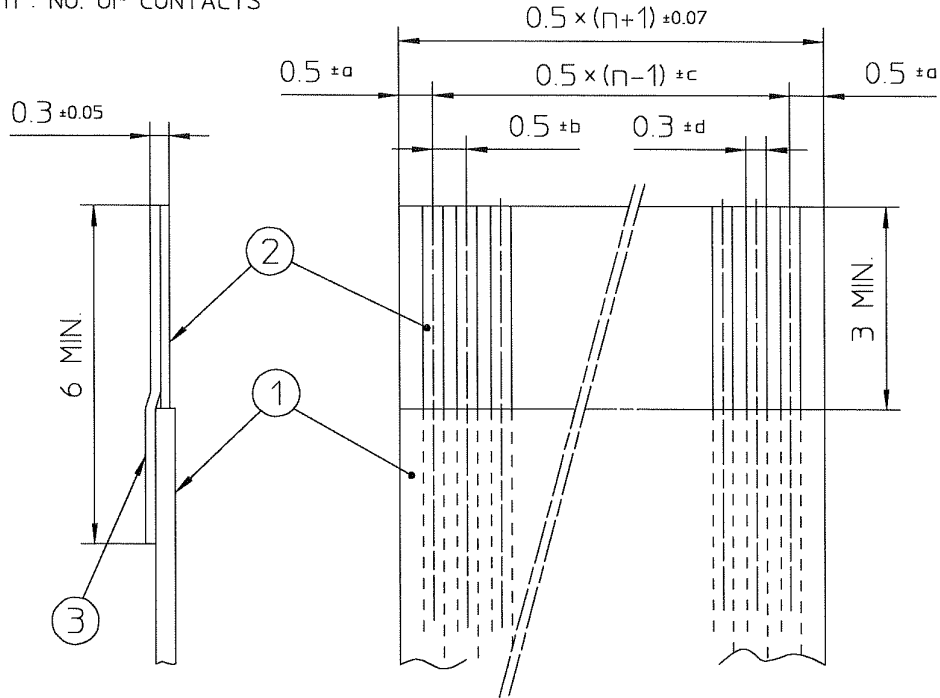

KIND OF FFC (NOTE3)	DIMENSIONAL TOLERANCE			
	a	b	c	d
1	±0.07	±0.04	±0.05	±0.02
2	±0.1	±0.03	±0.03	±0.025

PT. NO.	PARTS NAME	MATERIAL
1	INSULATOR	FLAME RESISTING POLYESTER OR EQUAL
2	CONDUCTOR	COPPER FOIL (PLATING : GOLD)
3	SUPPORTING TAPE	FLAME RESISTING POLYESTER OR EQUAL

NOTES

1. NO BURR AT EACH PORTION.
2. NO PEELING IN COMMON USE.
3. EITHER KIND1 OR KIND2 OF FFC CAN ACCEPT DIMENSIONAL TOLERANCE a,b,c AND d.

mat'l. code				surface ISO 1302 ✓		tolerance ISO 406 ISO 1101		projection		product family 58EF		
ltr	ecn no	dr	date	tolerances unless otherwise specified				title				
A	J06-0499	H.T	11/27/06					RECOMMENDED CABLE (Cat. No. : SFV__R-1/2ST__)				
				angles	linear		scale \times		dwg no sheet 1 of 1 size			
				dr	11/27/06				JSA 97202 A4			
				enr	11/27/06				type Product Customer Drawing			
				chr	11/27/06							
				appd	11/28/06							
sheet index	revision sheet	A	1									Rev. A



FCJconnect.com

Copyright FCJ