

List of "SFV\_\_R-1/2STBE9LF" customer document

DOCUMENT NO.	LIST
10101543(SHEET1)	CAT.NO.TABLE FOR 0.5mm CONTACT SPACING CONNECTOR (SFV__R-1/2STB_LF)
10101543(SHEET2)	CONNECTOR USED FOR FPC/FFC WITH 0.5mm CONTACT SPACING (SFV__R-1STB_LF)
10101543(SHEET3)	CONNECTOR USED FOR FPC/FFC WITH 0.5mm CONTACT SPACING (SFV__R-2STB_LF)
10101543(SHEET4)	CAT.NO.TABLE FOR PLASTIC TAPE PACKAGED 0.5mm CONTACT SPACING CONNECTOR (SFV__R-1/2STBE9LF)
10101543(SHEET5)	PLASTIC TAPE PACKAGED 0.5mm CONTACT SPACING CONNECTOR (SFV__R-1STBE9LF)
10101543(SHEET6)	PLASTIC TAPE PACKAGED 0.5mm CONTACT SPACING CONNECTOR (SFV__R-2STBE9LF)
10101543(SHEET7)	RECOMMENDED CABLE (FPC) (SFV__R-1/2STB__LF)
10101543(SHEET8)	RECOMMENDED CABLE (FFC) (SFV__R-1/2STB__LF)
SC-SFV06	PRODUCT SPECIFICATION
BJM-SFV101	HANDLING PROCEDURES



FCIconnect.com

Copyright FCI.

mat'l. code		surface 58 ISO 1302		tolerance ISO 406 ISO 1101		projection 		product family 58EF			
ltr	ecn no	dr	date	tolerances unless otherwise specified		mm 		title 0.5mm SPACING FPC/FFC CONNECTOR DOCUMENT LIST (Cat. No. : SFV__R-1/2STBE9LF)			
A	S09-0159	DGOH	09-05-15	angles	linear	scale $\times$		dwg no 10101543			
								sheet 1 of 9 A4			
				dr	DENNIS GOH	09-05-15	type Product Customer Drawing				
				enr	DENNIS GOH	09-05-15					
				chr	DENNIS GOH	09-05-15					
				appd	JOEY NG	09-05-15					
sheet index	revision sheet	A 1	A 2	A 3	A 4	A 5	A 6	A 7	A 8	A 9	Rev. A

form: A4

CAT. NO. & DIMENSIONS

NO. OF CONTACTS (n)	CAT. NO.	DIMENSIONS (NOTE2)			
		A ± 0.2	B ± 0.2	C ± 0.1	D ± 0.1
4	SFV4R-1/2STB__LF	7.5	5.9	1.5	2.7
5	SFV5R-1/2STB__LF	8.0	6.4	2.0	3.2
6	SFV6R-1/2STB__LF	8.5	6.9	2.5	3.7
7	SFV7R-1/2STB__LF	9.0	7.4	3.0	4.2
8	SFV8R-1/2STB__LF	9.5	7.9	3.5	4.7
9	SFV9R-1/2STB__LF	10.0	8.4	4.0	5.2
10	SFV10R-1/2STB__LF	10.5	8.9	4.5	5.7
11	SFV11R-1/2STB__LF	11.0	9.4	5.0	6.2
12	SFV12R-1/2STB__LF	11.5	9.9	5.5	6.7
13	SFV13R-1/2STB__LF	12.0	10.4	6.0	7.2
14	SFV14R-1/2STB__LF	12.5	10.9	6.5	7.7
15	SFV15R-1/2STB__LF	13.0	11.4	7.0	8.2
16	SFV16R-1/2STB__LF	13.5	11.9	7.5	8.7
17	SFV17R-1/2STB__LF	14.0	12.4	8.0	9.2
18	SFV18R-1/2STB__LF	14.5	12.9	8.5	9.7
19	SFV19R-1/2STB__LF	15.0	13.4	9.0	10.2
20	SFV20R-1/2STB__LF	15.5	13.9	9.5	10.7
21	SFV21R-1/2STB__LF	16.0	14.4	10.0	11.2
22	SFV22R-1/2STB__LF	16.5	14.9	10.5	11.7
23	SFV23R-1/2STB__LF	17.0	15.4	11.0	12.2
24	SFV24R-1/2STB__LF	17.5	15.9	11.5	12.7
25	SFV25R-1/2STB__LF	18.0	16.4	12.0	13.2
26	SFV26R-1/2STB__LF	18.5	16.9	12.5	13.7
27	SFV27R-1/2STB__LF	19.0	17.4	13.0	14.2
28	SFV28R-1/2STB__LF	19.5	17.9	13.5	14.7
29	SFV29R-1/2STB__LF	20.0	18.4	14.0	15.2
30	SFV30R-1/2STB__LF	20.5	18.9	14.5	15.7
31	SFV31R-1/2STB__LF	21.0	19.4	15.0	16.2
32	SFV32R-1/2STB__LF	21.5	19.9	15.5	16.7
33	SFV33R-1/2STB__LF	22.0	20.4	16.0	17.2
34	SFV34R-1/2STB__LF	22.5	20.9	16.5	17.7
35	SFV35R-1/2STB__LF	23.0	21.4	17.0	18.2

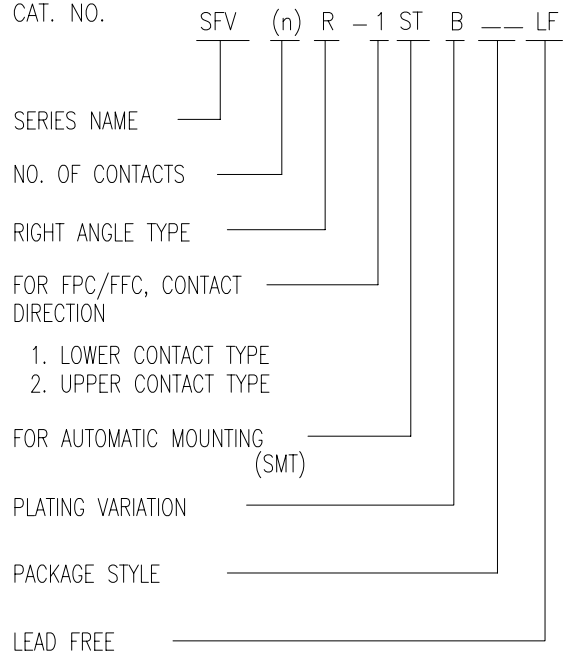

NOTES

- THIS PRODUCT IS THE CONNECTOR USED FOR FPC AND COPES WITH AUTOMATIC MOUNTING (SMT).
- SEE PART DRAWINGS FOR DIMENSIONS A~D.



FCIconnect.com

Copyright FCI.

mat'l. code		surface ISO 1302 <input checked="" type="checkbox"/>		tolerance ISO 406 <input checked="" type="checkbox"/>		projection		product family 58EF	
ltr	ecn no	dr	date	tolerances unless otherwise specified		mm		title	
A				angles	linear	scale <input checked="" type="checkbox"/>		CAT. NO. TABLE FOR 0.5 mm CONTACT SPACING CONNECTOR (Cat. No. : SFV__R-1/2STB__LF)	
		dr	DENNIS GOH		09-05-15			dwg no sheet 2 of 9 size	
		enr	DENNIS GOH		09-05-15			10101543 A4	
		chr	DENNIS GOH		09-05-15				
		appd	JOEY NG		09-05-15				
sheet index	revision sheet								Rev. A

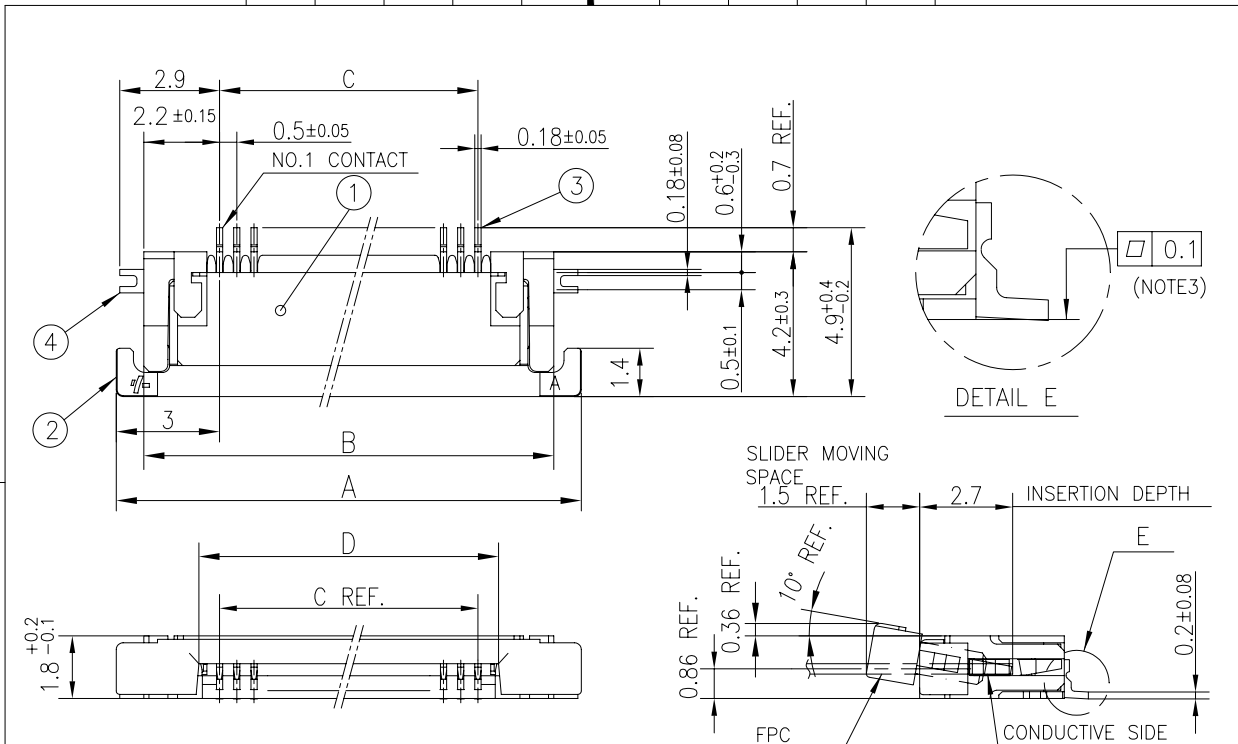

PT. NO.	PARTS NAME	MATERIAL	Q'TY	NOTE
1	HOUSING	POLYAMIDE RESIN GLASS REINFORCED (UL94V-0)	1	COLOR : BLACK
2	SLIDER	PPS RESIN GLASS REINFORCED (UL94V-0)	1	COLOR : BROWN
3	CONTACT	PHOSPHOR BRONZE	n	PLATING : GOLD
4	MOUNTING PLATE		2	PLATING : LEAD FREE

RECOMMENDED PC BOARD LAYOUT  
(COMPONENT SIDE)

PATTERN FOR MOUNTING PLATE FIXING

n : NO. OF CONTACTS

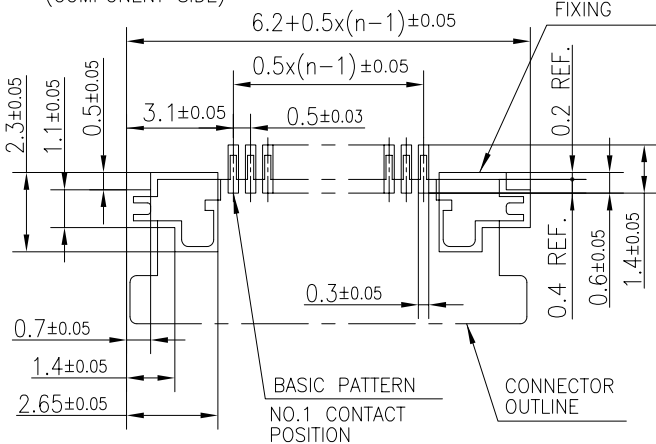

NOTES

1. THIS PRODUCT IS THE CONNECTOR USED FOR FPC AND COPES WITH AUTOMATIC MOUNTING (SMT).
2. THIS PRODUCT IS LOWER CONTACT TYPE CONNECTOR.
3. FLATNESS OF CONTACT TERMINAL AND MOUNTING PLATE MUST BE WITHIN TOLERANCE IN E PORTION DETAILED DRAWING.
4. THIS PRODUCT MEETS EUROPEAN UNION DIRECTIVES AND OTHER COUNTRY REGULATIONS AS DESCRIBED IN GS-22-008.
5. THE HOUSING WILL WITHSTAND EXPOSURE TO 260°C PEAK TEMPERATURE FOR 10 SECONDS IN A REFLOW SOLDERING OVEN.

mat'l. code		surface ISO 1302 ✓		tolerance ISO 406 ISO 1101		projection		product family 58EF	
ltr ecn no dr date		tolerances unless otherwise specified		mm		mm		title	
A		angles linear ±0.2		mm		mm		CONNECTOR USED FOR FPC WITH 0.5 mm CONTACT SPACING (Cat No. : SFV__R-1STB__LF)	
		dr DENNIS GOH 09-05-15		engr DENNIS GOH 09-05-15		chr DENNIS GOH 09-05-15		appd DENNIS GOH 09-05-15	
sheet index		revision sheet		FCL		dwg no 10101543		sheet 3 of 9 size A4	
						type Product Customer Drawing		Rev. A	

form: A4

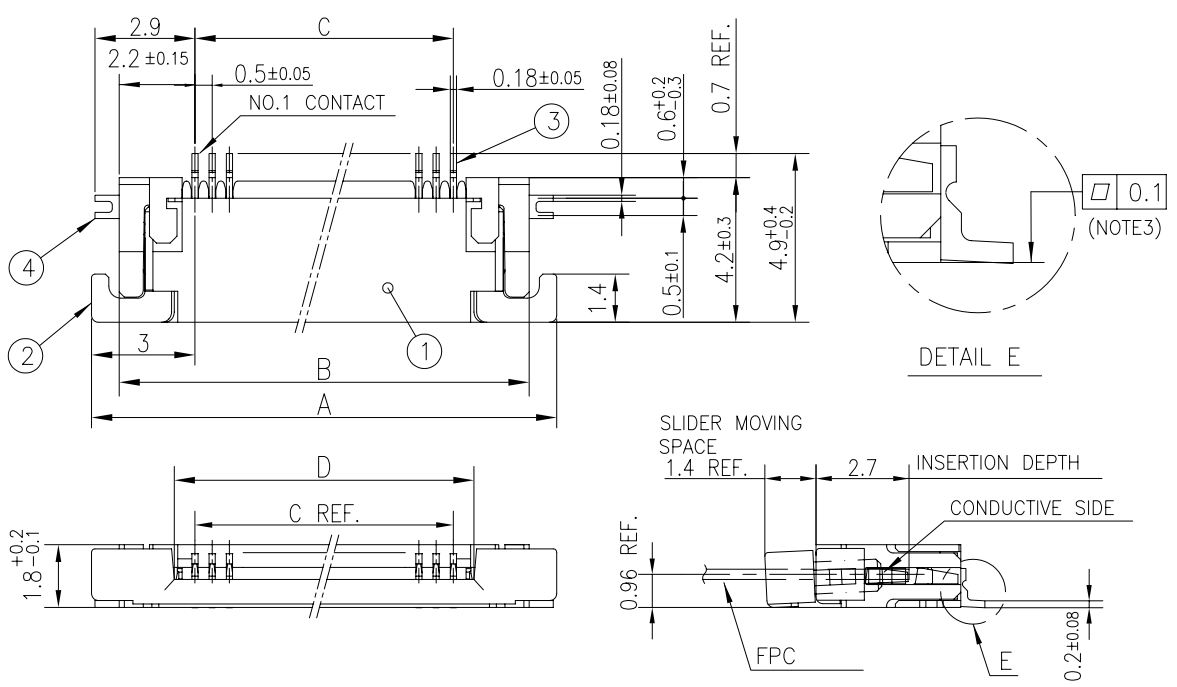

PT. NO.	PARTS NAME	MATERIAL	Q'TY	NOTE
1	HOUSING	POLYAMIDE RESIN GLASS REINFORCED (UL94V-0)	1	COLOR : BLACK
2	SLIDER	PPS RESIN GLASS REINFORCED (UL94V-0)	1	COLOR : BROWN
3	CONTACT	PHOSPHOR BRONZE	n	PLATING : GOLD
4	MOUNTING PLATE		2	PLATING : LEAD FREE

RECOMMENDED PC BOARD LAYOUT  
(COMPONENT SIDE)

PATTERN FOR MOUNTING PLATE FIXING

n : NO. OF CONTACTS

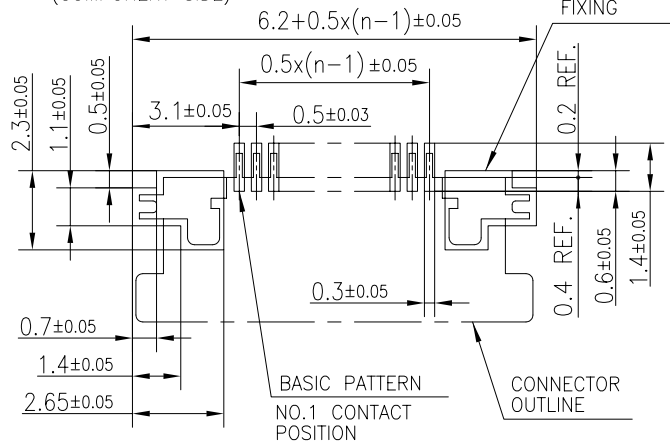

- NOTES
- THIS PRODUCT IS THE CONNECTOR USED FOR FPC AND COPE WITH AUTOMATIC MOUNTING (SMT).
  - THIS PRODUCT IS UPPER CONTACT TYPE CONNECTOR.
  - FLATNESS OF CONTACT TERMINAL AND MOUNTING PLATE MUST BE WITHIN TOLERANCE IN E PORTION DETAILED DRAWING.
  - THIS PRODUCT MEETS EUROPEAN UNION DIRECTIVES AND OTHER COUNTRY REGULATIONS AS DESCRIBED IN GS-22-008.
  - THE HOUSING WILL WITHSTAND EXPOSURE TO 260°C PEAK TEMPERATURE FOR 10 SECONDS IN A REFLOW SOLDERING OVEN.

mat'l. code		surface ISO 1302 ✓		tolerance ISO 406 ISO 1101		projection		product family 58EF	
ltr	ecn no	dr	date	tolerances unless otherwise specified		mm		title	
A				angles	linear ±0.2	mm		CONNECTOR USED FOR FPC WITH 0.5 mm CONTACT SPACING (Cat. No. : SFV__R-2STB__LF)	
				dr	DENNIS GOH 09-05-15	scale		dwg no sheet 4 of 9 size	
				enr	DENNIS GOH 09-05-15	mm		10101543 A4	
				chr	DENNIS GOH 09-05-15	mm		type Product Customer Drawing	
				appd	DENNIS GOH 09-05-15	mm		Rev. A	
sheet index	revision sheet								



FCIconnect.com

Copyright FCI.



CAT. NO. & DIMENSIONS

NO. OF CONTACTS (n)	CAT. NO.	DIMENSIONS (NOTE3)		
		F MAX.	G ± 0.3	H ± 0.1
4	SFV4R-1/2STBE9LF	22.4	16	—
5	SFV5R-1/2STBE9LF	22.4	16	—
6	SFV6R-1/2STBE9LF	22.4	16	—
7	SFV7R-1/2STBE9LF	30.4	24	—
8	SFV8R-1/2STBE9LF	30.4	24	—
9	SFV9R-1/2STBE9LF	30.4	24	—
10	SFV10R-1/2STBE9LF	30.4	24	—
11	SFV11R-1/2STBE9LF	30.4	24	—
12	SFV12R-1/2STBE9LF	30.4	24	—
13	SFV13R-1/2STBE9LF	30.4	24	—
14	SFV14R-1/2STBE9LF	30.4	24	—
15	SFV15R-1/2STBE9LF	30.4	24	—
16	SFV16R-1/2STBE9LF	30.4	24	—
17	SFV17R-1/2STBE9LF	30.4	24	—
18	SFV18R-1/2STBE9LF	30.4	24	—
19	SFV19R-1/2STBE9LF	30.4	24	—
20	SFV20R-1/2STBE9LF	30.4	24	—
21	SFV21R-1/2STBE9LF	30.4	24	—
22	SFV22R-1/2STBE9LF	30.4	24	—
23	SFV23R-1/2STBE9LF	38.4	32	28.4
24	SFV24R-1/2STBE9LF	38.4	32	28.4
25	SFV25R-1/2STBE9LF	38.4	32	28.4
26	SFV26R-1/2STBE9LF	38.4	32	28.4
27	SFV27R-1/2STBE9LF	38.4	32	28.4
28	SFV28R-1/2STBE9LF	38.4	32	28.4
29	SFV29R-1/2STBE9LF	38.4	32	28.4
30	SFV30R-1/2STBE9LF	38.4	32	28.4
31	SFV31R-1/2STBE9LF	50.4	44	40.4
32	SFV32R-1/2STBE9LF	50.4	44	40.4
33	SFV33R-1/2STBE9LF	50.4	44	40.4
34	SFV34R-1/2STBE9LF	50.4	44	40.4
35	SFV35R-1/2STBE9LF	50.4	44	40.4

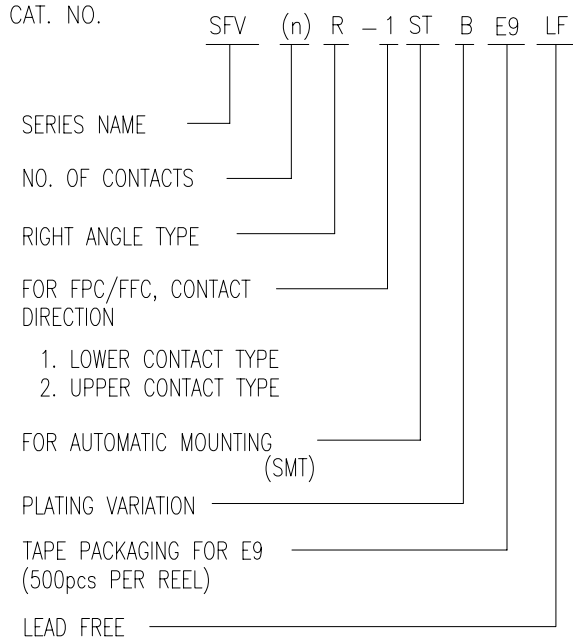

- NOTES
1. THIS PRODUCT IS THE CONNECTOR USED FOR FPC/FFC AND COPEs WITH AUTOMATIC MOUNTING (SMT).
  2. THIS CATALOG NO. INDICATES PLASTIC TAPE PACKAGED CONNECTOR.
  3. SEE PART DRAWINGS FOR DIMENSIONS F~H.



FCIconnect.com

Copyright FCI.

mat'l. code		surface ISO 1302 <input checked="" type="checkbox"/>		tolerance ISO 406 <input checked="" type="checkbox"/>		projection		product family 58EF	
ltr	ecn no	dr	date	tolerances unless otherwise specified		mm		title	
A				angles	linear	scale <input checked="" type="checkbox"/>		CAT. NO. TABLE FOR PLASTIC TAPE PACKAGED 0.5 mm CONTACT SPACING CONNECTOR (Cat. No. : SFV__R-1/2STBE9LF)	
		dr	DENNIS GOH	09-05-15				dwg no sheet 5 of 9 size	
		enr	DENNIS GOH	09-05-15				10101543 A4	
		chr	DENNIS GOH	09-05-15					
		appd	JOEY NG	09-05-15					
sheet index	revision sheet								Rev. A

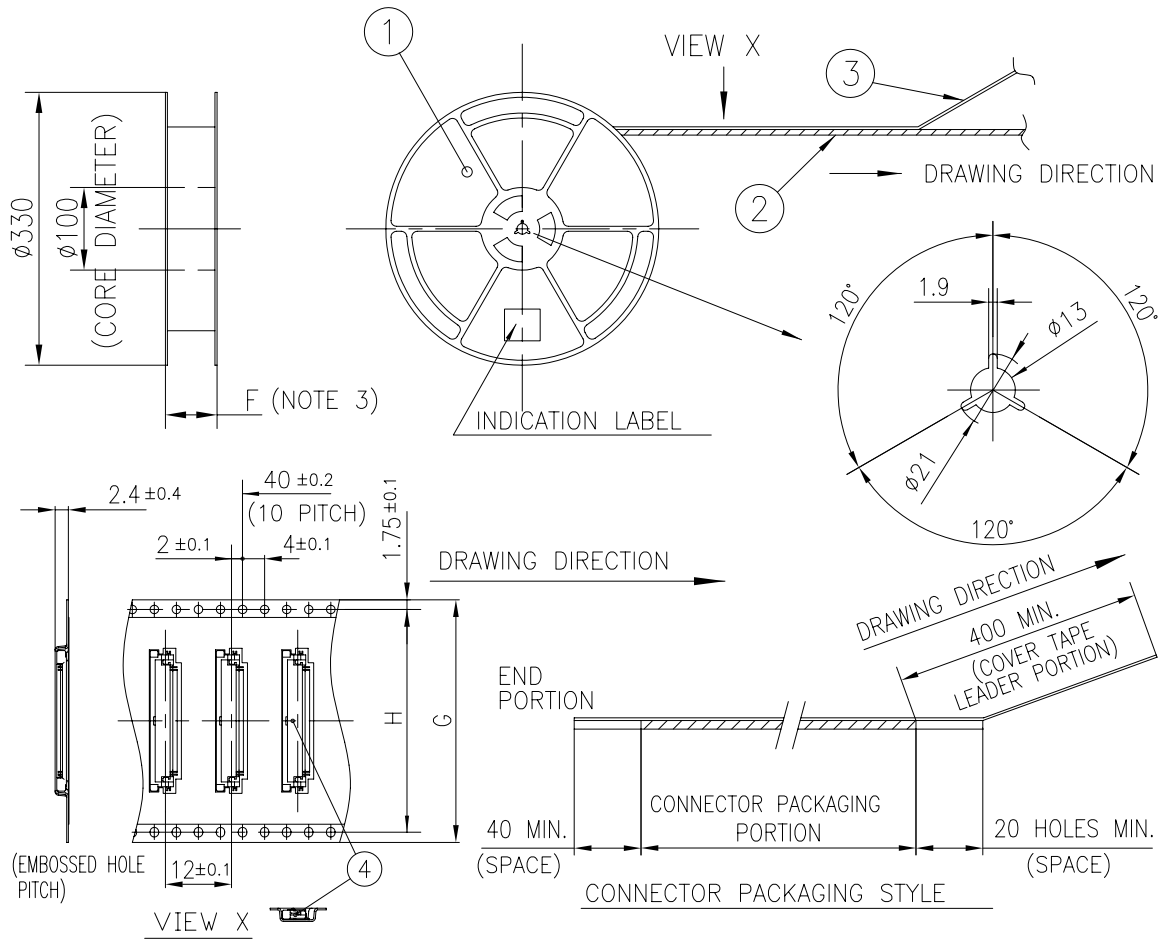

PT. NO.	PARTS NAME	CAT. NO.	MATERIAL	Q'TY	NOTE
1	REEL	_____	POLYSTYRENE	1	COLOR : BLACK
2	PLASTIC (EMBOSS) TAPE	_____	A-PET	_____	COLOR : TRANSPARENCY (CLEAR)
3	COVER	_____	POLYESTER	_____	COLOR : TRANSPARENCY (CLEAR)
4	CONNECTOR	SFV__R-1STB__LF	SEE ATTACHED DWG.	500	LOWER CONTACT TYPE

- NOTES
1. THIS IS PLASTIC TAPE PACKAGED CONNECTOR USED FOR FPC/FFC AND COPES WITH AUTOMATIC MOUNTING (SMT).
  2. SEE JIS C 0806 (PACKING OF ELECTRONIC COMPONENTS ON CONTINUOUS TAPES (SURFACE MOUNTING DEVICES)) FOR SHAPE AND DIMENSIONS OF PLASTIC (EMBOSS) TAPE AND REEL.
  3. F DIMENSION IS PORTION OF THE CORE.

mat'l. code		surface ISO 1302 ✓		tolerance ISO 406 ISO 1101		projection		product family 58EF	
ltr ecn no dr date		tolerances unless otherwise specified		±5		mm		title PLASTIC TAPE PACKAGED 0.5 mm CONTACT SPACING CONNECTOR (Cat. No. : SFV__R-1STBE9LF)	
A		angles linear		±5'		scale		dwg no sheet 6 of 9 size	
		dr DENNIS GOH 09-05-15		enr DENNIS GOH 09-05-15		chr DENNIS GOH 09-05-15		appd JOEY NG 09-05-15	
						FCJ		10101543 A4	
								type Product Customer Drawing	
sheet index		revision sheet						Rev. A	



FCIconnect.com

Copyright FCI.



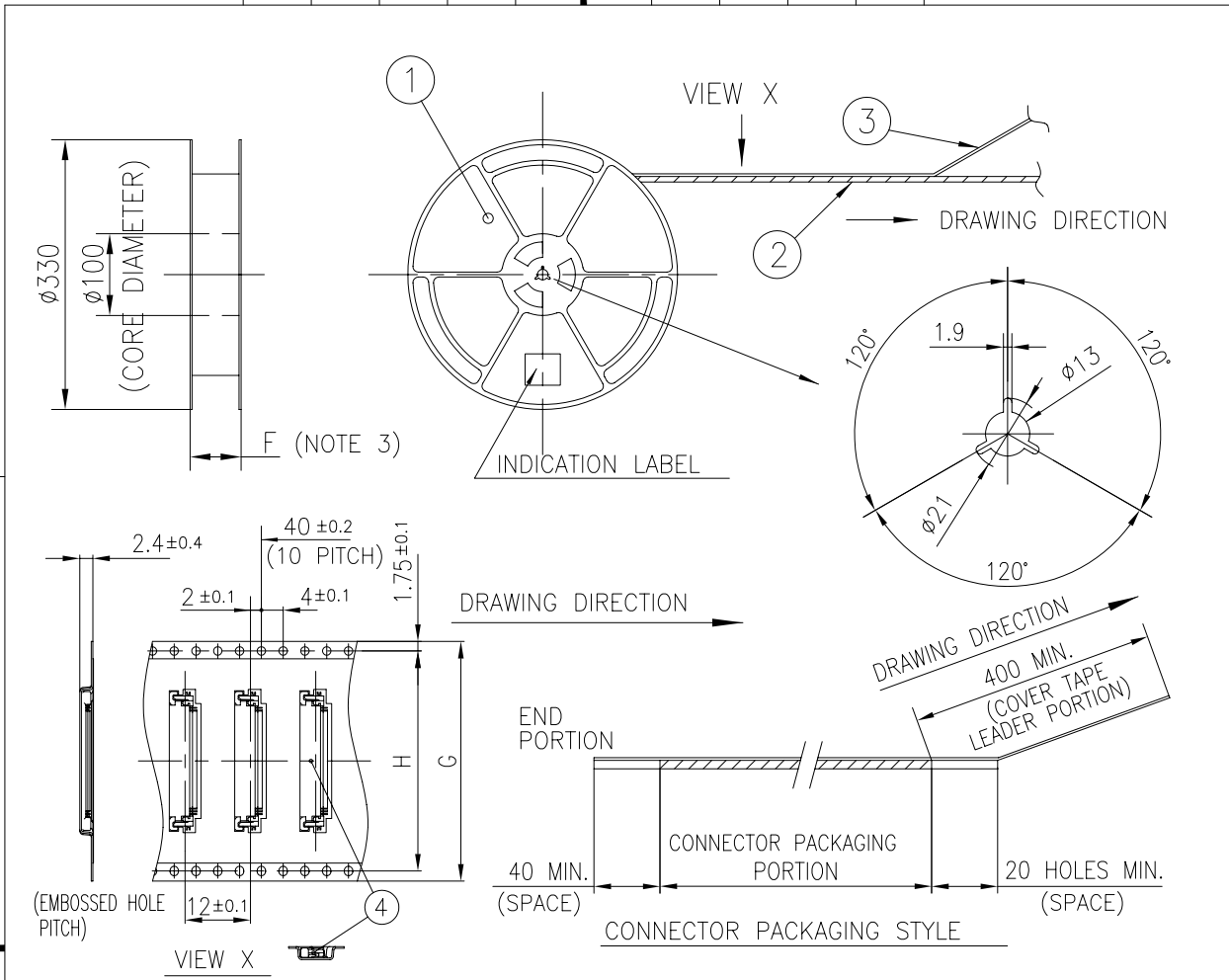

PT. NO.	PARTS NAME	CAT. NO.	MATERIAL	Q'TY	NOTE
1	REEL	_____	POLYSTYRENE	1	COLOR : BLACK
2	PLASTIC (EMBOSS) TAPE	_____	A-PET	_____	COLOR : TRANSPARENCY (CLEAR)
3	COVER	_____	POLYESTER	_____	COLOR : TRANSPARENCY (CLEAR)
4	CONNECTOR	SFV__R-2STB__LF	SEE ATTACHED DWG.	500	LOWER CONTACT TYPE

NOTES

1. THIS IS PLASTIC TAPE PACKAGED CONNECTOR USED FOR FPC/FFC AND COPES WITH AUTOMATIC MOUNTING (SMT).
2. SEE JIS C 0806 (PACKING OF ELECTRONIC COMPONENTS ON CONTINUOUS TAPES (SURFACE MOUNTING DEVICES)) FOR SHAPE AND DIMENSIONS OF PLASTIC (EMBOSS) TAPE AND REEL.
3. F DIMENSION IS PORTION OF THE CORE.

mat'l. code		surface ISO 1302 ✓		tolerance ISO 406 ISO 1101		projection		product family 58EF	
ltr ecn no dr date		tolerances unless otherwise specified		±5		mm		title PLASTIC TAPE PACKAGED 0.5 mm CONTACT SPACING CONNECTOR (Cat. No. : SFV__R-2STBE9LF)	
A		angles linear		±5'		scale		dwg no sheet 7 of 9 size	
		dr DENNIS GOH 09-05-15		enr DENNIS GOH 09-05-15		chr DENNIS GOH 09-05-15		10101543 A4	
		appd JOEY NG 09-05-15						type Product Customer Drawing	
sheet index		revision sheet						Rev. A	



Copyright FCI.

RECOMMENDED CABLE (FPC)

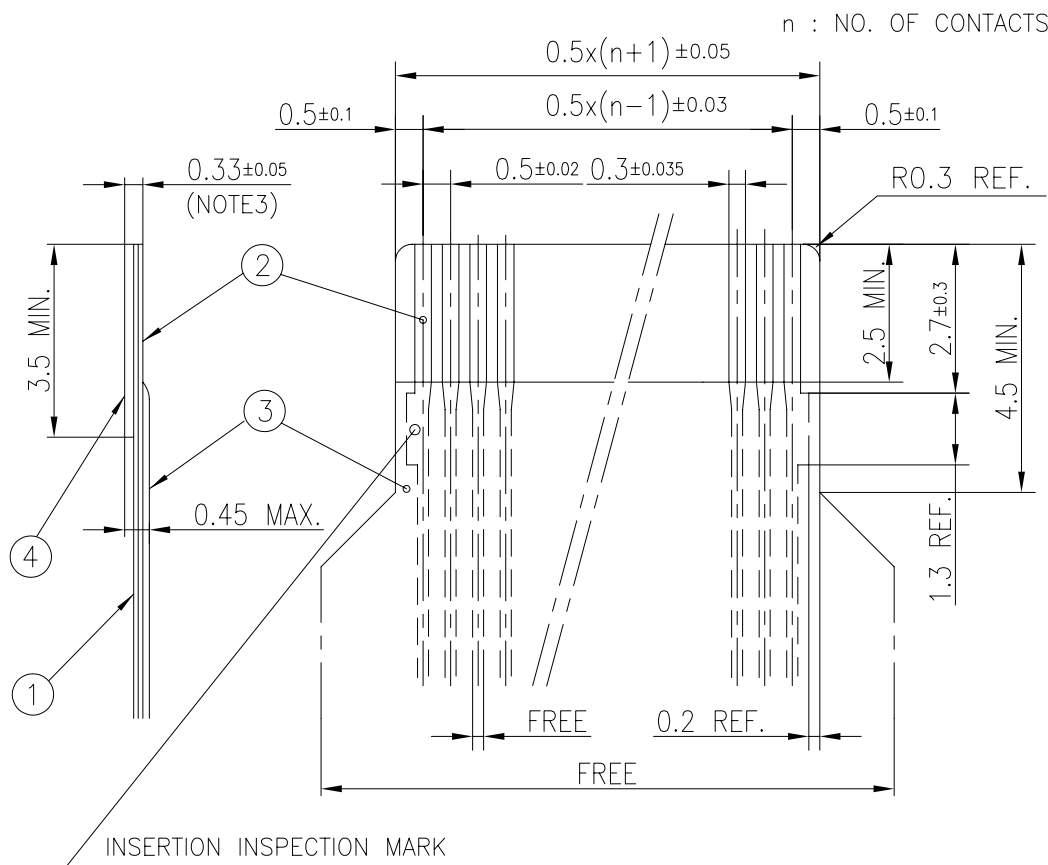

PT. NO.	PARTS NAME	MATERIAL	THICKNESS (um)
1	BASE FILM	POLYIMIDE OR POLYESTER OR EQUAL	25
2	CONDUCTOR	COPPER FOIL(PLATING : GOLD )	35
3	OVERLAY	POLYIMIDE OR POLYESTER OR EQUAL	—
4	SUPPORTING TAPE	POLYESTER OR POLYIMIDE OR EQUAL	188

NOTES

1. NO BURR AT EACH PORTION.
2. NO PEELING IN COMMON USE.
3. TOTAL THICKNESS LIMIT OF EACH MATERIAL (INCLUDING ADHESIVE AGENT) IS SPECIFIED.

mat'l. code		surface ISO 1302 <input checked="" type="checkbox"/>		tolerance ISO 406 <input checked="" type="checkbox"/>		projection		product family 58EF	
ltr	ecn no	dr	date		tolerances unless otherwise specified		title		RECOMMENDED CABLE (Cat. No. : SFV__R-1/2ST__LF)
A					angles linear		mm		
				dr DENNIS GOH 09-05-15		scale <input checked="" type="checkbox"/>		dwg no sheet 8 of 9 size	
				enr DENNIS GOH 09-05-15				10101543 A4	
				chr DENNIS GOH 09-05-15				type Product Customer Drawing	
				appd JOEY NG 09-05-15					
sheet index	revision sheet							Rev. A	



FCJconnect.com

Copyright FCJ.





RECOMMENDED CABLE (FFC)

n : NO. OF CONTACTS

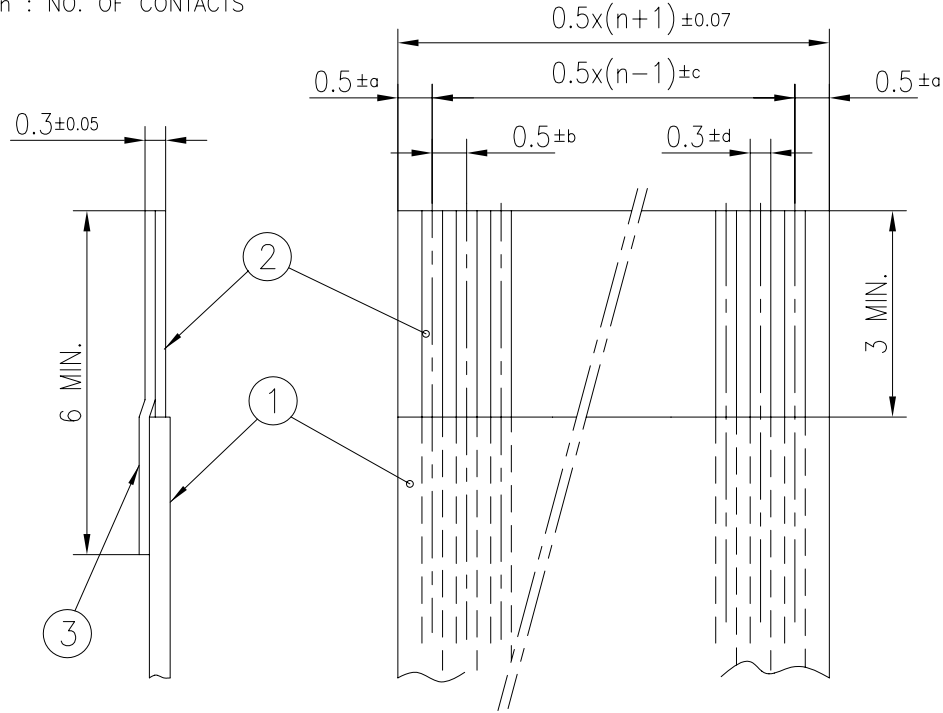

KIND OF FFC (NOTE3)	DIMENSIONAL TOLERANCE			
	a	b	c	d
1	±0.07	±0.04	±0.05	±0.02
2	±0.1	±0.03	±0.03	±0.025

PT. NO.	PARTS NAME	MATERIAL
1	INSULATOR	FLAME RESISTING POLYESTER OR EQUAL
2	CONDUCTOR	COPPER FOIL (PLATING : GOLD)
3	SUPPORTING TAPE	FLAME RESISTING POLYESTER OR EQUAL

NOTES

1. NO BURR AT EACH PORTION.
2. NO PEELING IN COMMON USE.
3. EITHER KIND1 OR KIND2 OF FFC CAN ACCEPT DIMENSIONAL TOLERANCE a,b,c AND d.

mat'l. code		surface ISO 1302 <input checked="" type="checkbox"/>		tolerance ISO 406 <input checked="" type="checkbox"/>		projection		product family 58EF	
ltr ecn no dr date		tolerances unless otherwise specified		mm		title		RECOMMENDED CABLE (Cat. No. : SFV__R-1/2ST__LF)	
A		angles linear		scale $\times$		dwg no		sheet 9 of 9 size A4	
		dr DENNIS GOH 09-05-15		FCJ		10101543			
		enr DENNIS GOH 09-05-15				type Product Customer Drawing			
		chr DENNIS GOH 09-05-15							
		appd JOEY NG 09-05-15							
sheet index		revision sheet						Rev. A	



FCIconnect.com

Copyright FCI.

