

(FLATNESS OF CONTACT TERMINAL AND MOUNTING PLATE)  
 MISALIGNMENT OF SOLDER TAIL AND FITTING NAIL FROM DATUM E  
 : UPPER DIRECTION .10 MAX. , LOWER DIRECTION 0.15 MAX.

※ <<ALTERNATE CORE AND RIB CONSTRUCTION, NON-FUNCTION,  
 AND OR FOR PLASTIC MOLDING PROCESS PURPOSE>>

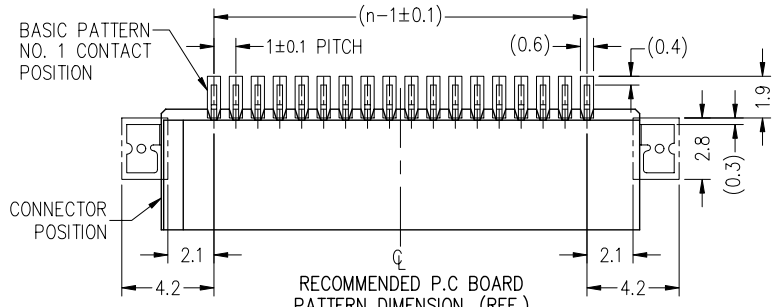

RECOMMENDED SOLDER PASTE  
 THICK 0.15mm [.006"] MIN.

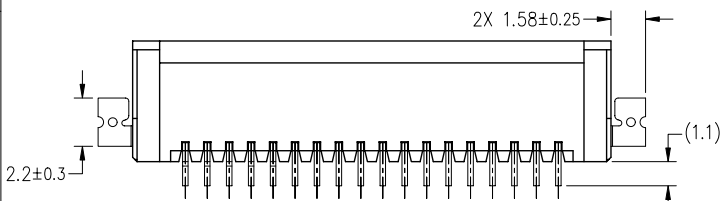

mat'l. code				tolerances unless otherwise specified				projection		product family	
ltr	ecn no	dr	date	angles	linear	-----	-----	mm		FFC/FPC	
A	S07-0203	SLLIM	070615	x±2'	-----	-----	-----	mm		title	
B	S07-0450	SLLIM	071226		-----	-----	-----	mm		1mm SPACING SMT	
C	S08-0180	SLLIM	080819		-----	-----	-----	mm		FFC/FPC CONNECTOR	
				dr	SLLIM	060907	scale 4:1		dwg no		
				enr	SLLIM	060907			sheet 1 of 6		
				chr	SLLIM	060907			size		
				appd	JOEY NG	060908			10073872		
				sheet index		revision		C		type	
				sheet		1		2		Product Customer Drawing	
						3		4		A4	
						5		6			

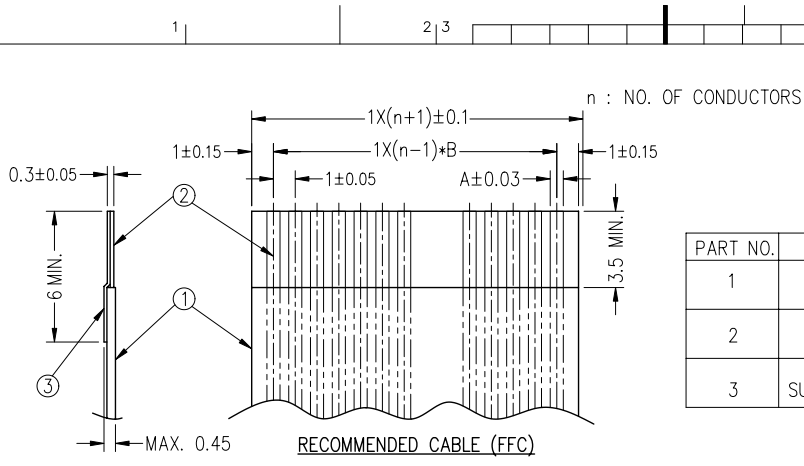

(NOTE C)	DIMENSION A	TOLERANCE B
1	0.7	0.1
2	0.6	0.07

RECOMMENDED CABLE (FFC)

PART NO.	DESCRIPTION	MATERIAL	NOTE
1	INSULATOR	FLAME RESISTING POLYESTER OR EQUIVALENT	-----
2	CONDUCTOR	COPPER FOIL	PLATING: TIN OR SOLDER 1um MIN.
3	SUPPORTING TAPE	FLAME RESISTING POLYESTER OR EQUIVALENT	-----

- NOTES:
- A.) NO BURR AT EACH PORION.
  - B.) NO PEELING IN COMMON USE.
  - C.) BOTH COMBINATION IS ALLOWED.

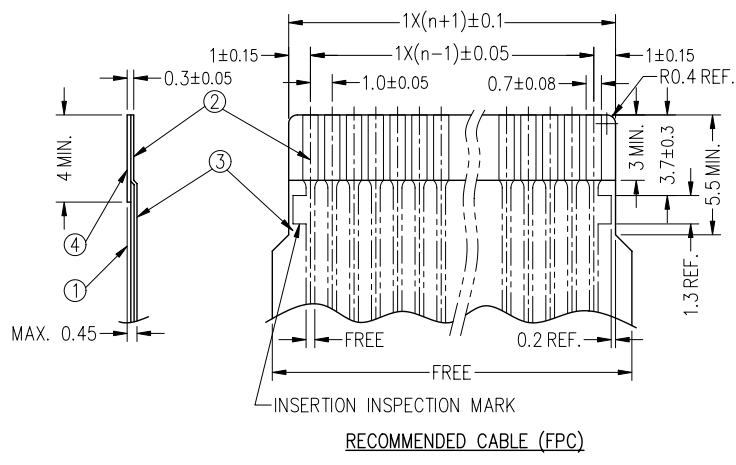

RECOMMENDED CABLE (FPC)

PART NO.	DESCRIPTION	MATERIAL	THICKNESS (um)
1	BASE FILM	POLYIMIDE OR POLYESTER OR EQUIVALENT	25
2	CONDUCTOR	COPPER FOIL (PLATING: SOLDER 1um MIN.)	35
3	OVERLAY	POLYIMIDE OR POLYESTER OR EQUIVALENT	-----
4	SUPPORTING TAPE	POLYIMIDE OR POLYESTER OR EQUIVALENT	188

mat'l. code				tolerances unless otherwise specified				projection		product family	
ltr	ecn no	dr	date	angles	linear	.XX±.20		mm		FFC/FPC	
c				x±z'		-----		scale 4:1		title	
				dr	SLLIM	060907				1mm SPACING SMT	
				enrg	SLLIM	060907				FPC/FFC CONNECTOR	
				chr	SLLIM	060907				dwg no	
				appd	JOEY NG	060908				sheet 2 of 6	
										size	
										A4	
										type	
										Product Customer Drawing	
sheet index	revision sheet										

PART NO.	PARTS NAME	MATERIAL	Q'TY	NOTE
1	HOUSING	HIGH TEMPERATURE THERMOPLASTIC REINFORCED (UL94V-0)	1	COLOR: BLACK
2	CONTACT	PHOSPHOR BRONZE	n	PLATING (LEAD FREE)
3	SMT CLIP	BRASS	2	

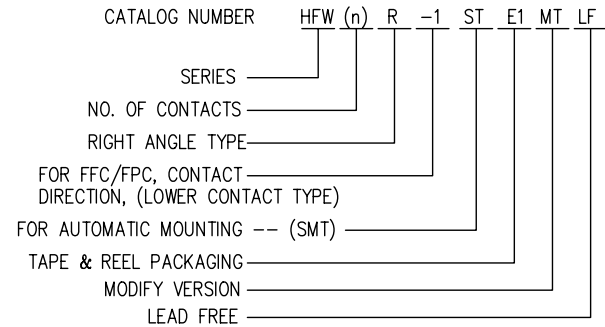

30	HFW30R-1STE1MTLF	29	31.14	33.8
29	HFW29R-1STE1MTLF	28	30.14	32.8
28	HFW28R-1STE1MTLF	27	29.14	31.8
27	HFW27R-1STE1MTLF	26	28.14	30.8
26	HFW26R-1STE1MTLF	25	27.14	29.8
25	HFW25R-1STE1MTLF	24	26.14	28.8
24	HFW24R-1STE1MTLF	23	25.14	27.8
23	HFW23R-1STE1MTLF	22	24.13	26.8
22	HFW22R-1STE1MTLF	21	23.14	25.8
21	HFW21R-1STE1MTLF	20	22.14	24.8
20	HFW20R-1STE1MTLF	19	21.14	23.8
19	HFW19R-1STE1MTLF	18	20.14	22.8
18	HFW18R-1STE1MTLF	17	19.14	21.8
17	HFW17R-1STE1MTLF	16	18.14	20.8
16	HFW16R-1STE1MTLF	15	17.14	19.8
15	HFW15R-1STE1MTLF	14	16.14	18.8
14	HFW14R-1STE1MTLF	13	15.14	17.8
13	HFW13R-1STE1MTLF	12	14.14	16.8
12	HFW12R-1STE1MTLF	11	13.14	15.8
11	HFW11R-1STE1MTLF	10	12.14	14.8
10	HFW10R-1STE1MTLF	9	11.14	13.8
9	HFW9R-1STE1MTLF	8	10.14	12.8
8	HFW8R-1STE1MTLF	7	9.14	11.8
7	HFW7R-1STE1MTLF	6	8.14	10.8
6	HFW6R-1STE1MTLF	5	7.14	9.8
5	HFW5R-1STE1MTLF	4	6.14	8.8
4	HFW4R-1STE1MTLF	3	5.14	7.8

NOTES

1. THIS PRODUCT IS THE CONNECTOR DESIGNED TO TERMINATE FPC/FFC AND COPES WITH AUTOMATIC MOUNTING (SMT).
2. MISALIGNMENT OF SOLDER TAIL AND SMT CLIP FROM DATUM E : UPPER DIRECTION 0.10 MAX. , LOWER DIRECTION 0.15 MAX.
3. THIS PRODUCT IS LOWER CONTACT TYPE CONNECTOR.
4. THIS PRODUCT IS MEETS EUROPEAN UNION DIRECTIVES AND OTHER COUNTRY REGULATIONS AS DESCRIBED IN GS-22-008.
5. THE HOUSING WILL WITHSTAND EXPOSURE TO 260°C PEAK TEMPERATURE FOR 10 SECONDS IN A REFLOW SOLDERING OVEN.
6. THIS PRODUCT IS LOWER CONTACT TYPE CONNECTOR.
7. THIS CATALOG NO. INDICATES PLASTIC TAPE PACKAGED CONNECTOR.

mat'l. code				tolerances unless otherwise specified			projection	product family
ltr	ecn no	dr	date	angles	linear	.XX±.20	mm	FFC/FPC
c				x±z'	dr	SLLIM 060907	scale 4:1	title
				enrg	chr	SLLIM 060907		1mm SPACING SMT
				appd	JOEY NG	060908		FPC/FFC CONNECTOR
sheet index	revision sheet							10073872
								sheet 3 of 6
								size A4
								type Product Customer Drawing

P/N:	PARTS NAME	CATALOG NO.	MATERIAL	QUANTITY	NOTE
①	REEL	-----	POLYSTYRENE (PS) <RECYCLE MATERIAL CONTAINED>	01	COLOR: BLACK
②	PLASTIC (EMBOSSED) CARRIER TAPE	-----	POLYSTYRENE (0.4mm Thick)	-----	COLOR: (CLEAR) TRANSPARENCY
③	COVER (TOP TAPE)	-----	POLYESTER	-----	COLOR: (CLEAR) TRANSPARENCY
④	CONNECTOR	HFW__R-1STE1MTLF	SEE ATTACHED DRAWING	1,000PCS/REEL	LOWER CONTACT TYPE

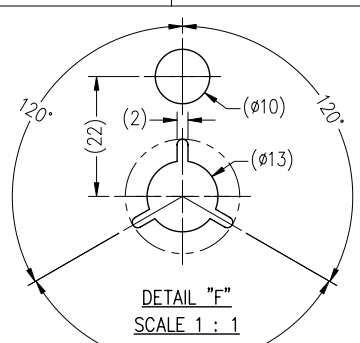

UNLESS OTHERWISE SPECIFIED: ±5, ANGLE ±5° TOLERANCES

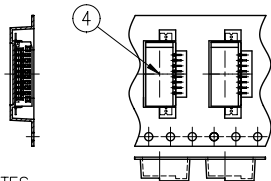

SCALE 4 : 1

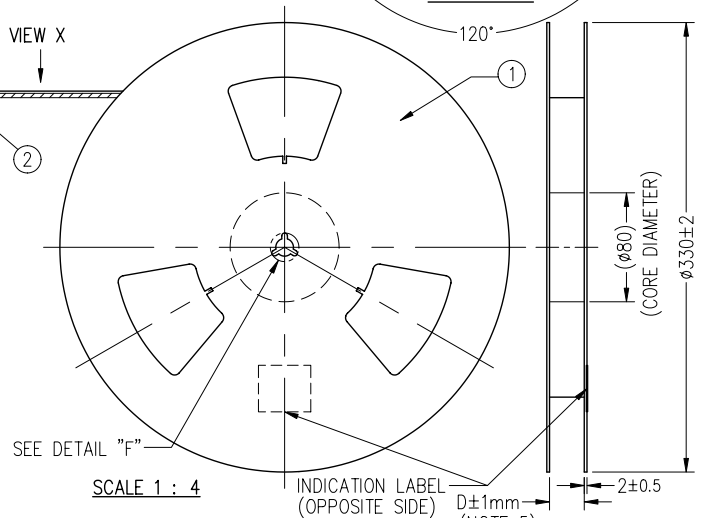
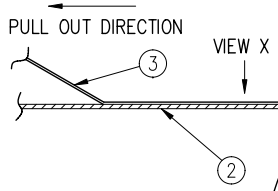

SCALE 1 : 4

NOTES

- THIS IS PLASTIC TAPE PACKAGED CONNECTOR DESIGNED TO TERMINATE FPC/FFC AND COPEs WITH AUTOMATIC MOUNTING (SMT).
- SEE JIS C 0806 (PACKING OF ELECTRONICS COMPONENTS ON CONTINUOUS TAPES, SURFACE MOUNT DEVICES) FOR SHAPE AND DIMENSIONS OF PLASTIC (EMBOSSED) TAPE AND REEL.
- LEAD TAPE LENGTH

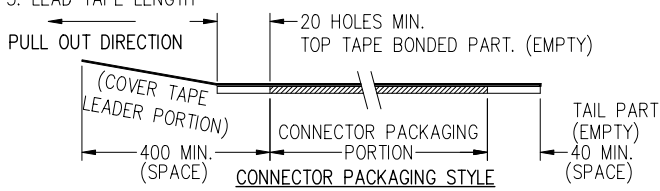

- PEELING OFF FORCE OF TOP TAPE TAPE: 0.1N~0.7N(10.2gf~71.4gf) (PEELING DIRECTION AS SHOWN IN FOLLOWING FIG.) THIS REQUIREMENT SHOULD BE APPLIED AT SHIPMENT. PEEL OFF SHOULD NOT BE ALLOWED, DURING TRANSPORTATION.

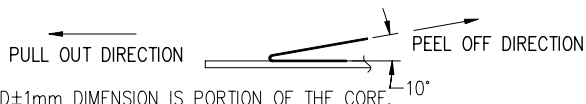

- D±1mm DIMENSION IS PORTION OF THE CORE.

mat'l. code				tolerances unless otherwise specified			projection		product family	
ltr	ecn no	dr	date	angles	linear	.XX±.20	mm	FFC/FFC		
c						scale 4:1		title		
								1mm SPACING SMT FPC/FFC CONNECTOR		
				dr	SLLIM	060907		dwg no		
				enrg	SLLIM	060907		sheet 4 of 6		
				chr	SLLIM	060907		size		
				appd	JOEY NG	060908		A4		
								type		
								Product Customer Drawing		
sheet index	revision sheet									

PDM: Rev:C

STATUS: Released

Printed: Jan 29, 2009

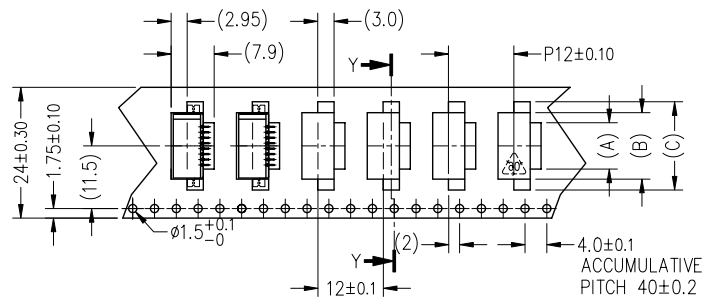
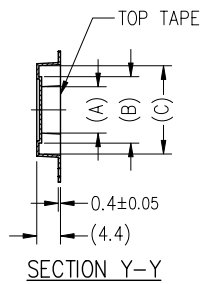

PULL OUT DIRECTION



24mm WIDTH CARRIER TAPE

10	HFW10R-1STE1MTLF	10.5	14.2	18.2	25.5	24
9	HFW9R-1STE1MTLF	9.5	13.2	17.2		
8	HFW8R-1STE1MTLF	8.5	12.2	16.2		
7	HFW7R-1STE1MTLF	7.5	11.2	15.5		
6	HFW6R-1STE1MTLF	6.5	10.2	14.2		
5	HFW5R-1STE1MTLF	5.5	9.2	13.2		
4	HFW4R-1STE1MTLF	4.5	8.2	12.2		
CIRCUIT	CATALOG NO.	(A)	(B)	(C)	D±1mm REEL CORE	CARRIER TAPE WIDTH

mat'l. code				tolerances unless otherwise specified			projection	product family	
ltr	ecn no	dr	date	angles	linear	.XX±.20	mm	FFC/FPC	
c				x±z'		scale 4:1			
				dr	SLLIM	060907		title	
				enrg	SLLIM	060907		1mm SPACING SMT FPC/FFC CONNECTOR	
				chr	SLLIM	060907		dwg no	sheet 5 of 6
				appd	JOEY NG	060908		10073872	size A4
sheet index	revision sheet							type Product Customer Drawing	

PDM: Rev:C

STATUS: Released

Printed: Jan 29, 2009

form: 44

1

2

3

4

5

6

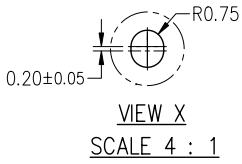

SECTION Y-Y

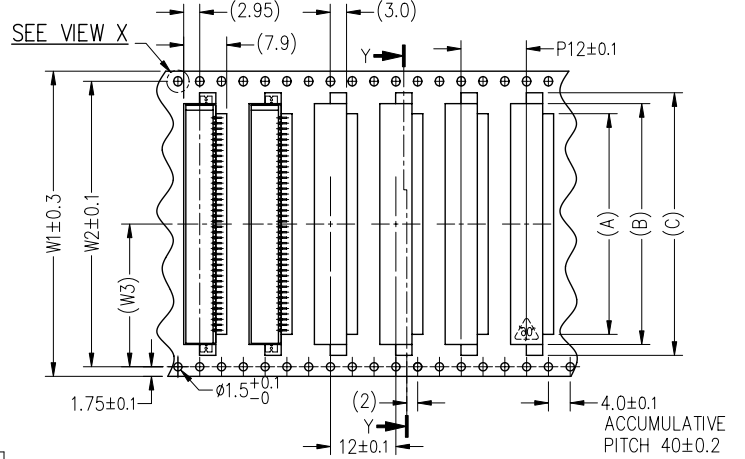
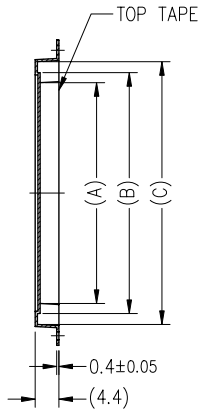

PULL OUT DIRECTION



32mm, 44mm, & 56mm WIDTH CARRIER TAPE

30	HFW30R-1STE1MTLF	30.5	34.2	38.2	57.5	56	52.4	26.2	
29	HFW29R-1STE1MTLF	29.5	33.2	37.2					
28	HFW28R-1STE1MTLF	28.5	32.2	36.2					
27	HFW27R-1STE1MTLF	27.5	31.2	35.2					
26	HFW26R-1STE1MTLF	26.5	30.2	34.2	45.5	44	40.4	20.2	
25	HFW25R-1STE1MTLF	25.5	29.2	33.2					
24	HFW24R-1STE1MTLF	24.5	28.2	32.2					
23	HFW23R-1STE1MTLF	23.5	27.2	31.2					
22	HFW22R-1STE1MTLF	22.2	26.2	30.2					
21	HFW21R-1STE1MTLF	21.5	25.2	29.2					
20	HFW20R-1STE1MTLF	20.5	24.2	28.2					
19	HFW19R-1STE1MTLF	19.5	23.2	27.2					
18	HFW18R-1STE1MTLF	18.5	22.2	26.2	33.5	32	28.4	14.2	
17	HFW17R-1STE1MTLF	17.5	21.2	25.2					
16	HFW16R-1STE1MTLF	16.5	20.2	24.2					
15	HFW15R-1STE1MTLF	15.5	19.2	23.2					
14	HFW14R-1STE1MTLF	14.5	18.2	22.2					
13	HFW13R-1STE1MTLF	13.5	17.2	21.2					
12	HFW12R-1STE1MTLF	12.5	16.2	20.2					
11	HFW11R-1STE1MTLF	11.5	15.2	19.2					
CIRCUIT	CATALOG NO.	(A)	(B)	(C)	D±1mm REEL CORE	W1	W2	(W3)	CARRIER TAPE

mat'l. code				tolerances unless otherwise specified			projection	product family
ltr	ecn no	dr	date	angles	linear	mm	FFC/FPC	
c				x±z'		scale 4:1	title	
				dr	SLLIM	060907	1mm SPACING SMT	
				enrg	SLLIM	060907	FPC/FFC CONNECTOR	
				chr	SLLIM	060907	dwg no	
				appd	JOEY NG	060908	10073872	
							sheet 6 of 6	
							size	
							A4	
							type	
							Product Customer Drawing	
sheet index	revision sheet							

PDM: Rev:C

STATUS: Released

Printed: Jan 29, 2009