



FCIconnect.com

Copyright FCI

A

B

C

D

1

2

List of "SFV\_\_R-3/4STBE1LF" customer document

DOCUMENT NO.	LIST
SC-SFV07	SPEC.
JSA96185	CAT.NO.TABLE FOR 0.5mm CONTACT SPACING CONNECTOR (SFV__R-3/4STB_LF)
JSA96186	CONNECTOR USED FOR FPC WITH 0.5mm CONTACT SPACING (SFV__R-3STB_LF)
JSA96187	CONNECTOR USED FOR FPC WITH 0.5mm CONTACT SPACING (SFV__R-4STB_LF)
JSA96188	CAT.NO.TABLE FOR PLASTIC TAPE PACKAGED 0.5mm CONTACT SPACING CONNECTOR (SFV__R-3/4STBE1LF)
JSA96189	PLASTIC TAPE PACKAGED 0.5mm CONTACT SPACING CONNECTOR (SFV__R-3STBE1LF)
JSA96190	PLASTIC TAPE PACKAGED 0.5mm CONTACT SPACING CONNECTOR (SFV__R-4STBE1LF)
JSA96191	RECOMMENDED CABLE (FPC) (SFV__R-3/4ST_LF)
BJM-SFV102	HANDLING PROCEDURES

A

B

C

D

mat'l. code				surface <input checked="" type="checkbox"/> ISO 1302 <input type="checkbox"/> tolerance <input checked="" type="checkbox"/> ISO 406 <input type="checkbox"/> ISO 1101		projection		product family 58EF	
ltr	ecn no	dr	date	tolerances unless otherwise specified				title	
A	J04-0454	H.T	'05/2/7	angles linear				0.5mm SPACING FPC CONNECTOR DOCUMENT LIST	
B	J06-0372	H.T	'06/9/7					(Cat. No. : SFV__R-3/4STBE1LF)	
				dr <i>H. Stohr</i> 9/7/06		scale $\times$		dwg no sheet 1 of 1 size	
				engr <i>H. Stohr</i> 9/7/06				JSA 96184 A4	
				chr <i>K. Stouje</i> 9/8/06				type Product Customer Drawing	
				appd <i>J. D. d. dan</i> 9/11/06					
sheet index	revision sheet	B	1					Rev. B	

form: A4

1

2

CAT. NO. & DIMENSIONS

NO. OF CONTACTS (n)	CAT. NO.	DIMENSIONS (NOTE2)			
		A ± 0.2	B ± 0.2	C ± 0.1	D ± 0.1
4	SFV 4R-3/4STB__LF	7.5	5.9	1.5	1.6
5	SFV 5R-3/4STB__LF	8.0	6.4	2.0	2.1
6	SFV 6R-3/4STB__LF	8.5	6.9	2.5	2.6
7	SFV 7R-3/4STB__LF	9.0	7.4	3.0	3.1
8	SFV 8R-3/4STB__LF	9.5	7.9	3.5	3.6
9	SFV 9R-3/4STB__LF	10.0	8.4	4.0	4.1
10	SFV10R-3/4STB__LF	10.5	8.9	4.5	4.6
11	SFV11R-3/4STB__LF	11.0	9.4	5.0	5.1
12	SFV12R-3/4STB__LF	11.5	9.9	5.5	5.6
13	SFV13R-3/4STB__LF	12.0	10.4	6.0	6.1
14	SFV14R-3/4STB__LF	12.5	10.9	6.5	6.6
15	SFV15R-3/4STB__LF	13.0	11.4	7.0	7.1
16	SFV16R-3/4STB__LF	13.5	11.9	7.5	7.6
17	SFV17R-3/4STB__LF	14.0	12.4	8.0	8.1
18	SFV18R-3/4STB__LF	14.5	12.9	8.5	8.6
19	SFV19R-3/4STB__LF	15.0	13.4	9.0	9.1
20	SFV20R-3/4STB__LF	15.5	13.9	9.5	9.6
21	SFV21R-3/4STB__LF	16.0	14.4	10.0	10.1
22	SFV22R-3/4STB__LF	16.5	14.9	10.5	10.6
23	SFV23R-3/4STB__LF	17.0	15.4	11.0	11.1
24	SFV24R-3/4STB__LF	17.5	15.9	11.5	11.6
25	SFV25R-3/4STB__LF	18.0	16.4	12.0	12.1
26	SFV26R-3/4STB__LF	18.5	16.9	12.5	12.6
27	SFV27R-3/4STB__LF	19.0	17.4	13.0	13.1
28	SFV28R-3/4STB__LF	19.5	17.9	13.5	13.6
29	SFV29R-3/4STB__LF	20.0	18.4	14.0	14.1
30	SFV30R-3/4STB__LF	20.5	18.9	14.5	14.6
31	SFV31R-3/4STB__LF	21.0	19.4	15.0	15.1
32	SFV32R-3/4STB__LF	21.5	19.9	15.5	15.6
33	SFV33R-3/4STB__LF	22.0	20.4	16.0	16.1
34	SFV34R-3/4STB__LF	22.5	20.9	16.5	16.6
35	SFV35R-3/4STB__LF	23.0	21.4	17.0	17.1

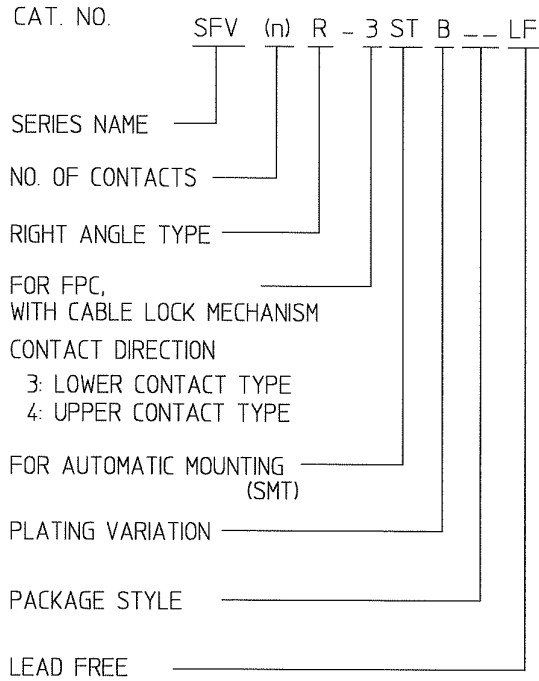

NOTES

1. THIS PRODUCT IS THE CONNECTOR USED FOR FPC AND COPES WITH AUTOMATIC MOUNTING (SMT).
2. SEE PART DRAWINGS FOR DIMENSIONS A-D.
3. THIS PRODUCT IS THE CONNECTOR WITH CABLE LOCK MECHANISM.



FCIconnect.com

Copyright FCI

mat'l. code				surface ISO 1302 <input checked="" type="checkbox"/>		tolerance ISO 406 ISO 1101		projection		product family 58EF	
ltr ecn no dr date				tolerances unless otherwise specified							
A J04-0454 H.T '05/2/7				angles		linear		scale X		title	
B J06-0372 H.T '06/9/7										CAT. NO. TABLE FOR 0.5 mm CONTACT SPACING CONNECTOR (Cat. No. : SFV__R-3/4STB__LF)	
				dr		9/9/06		FCI		dwg no sheet 1 of 1 size	
				enr		9/9/06				JSA 96185 A4	
				chr		9/8/06				type Product Customer Drawing	
				appd		9/10/06					
sheet index		revision B		sheet 1						Rev. B	

SC-SFV07 JSA96186, 96187, 96188, 96191 form: A4

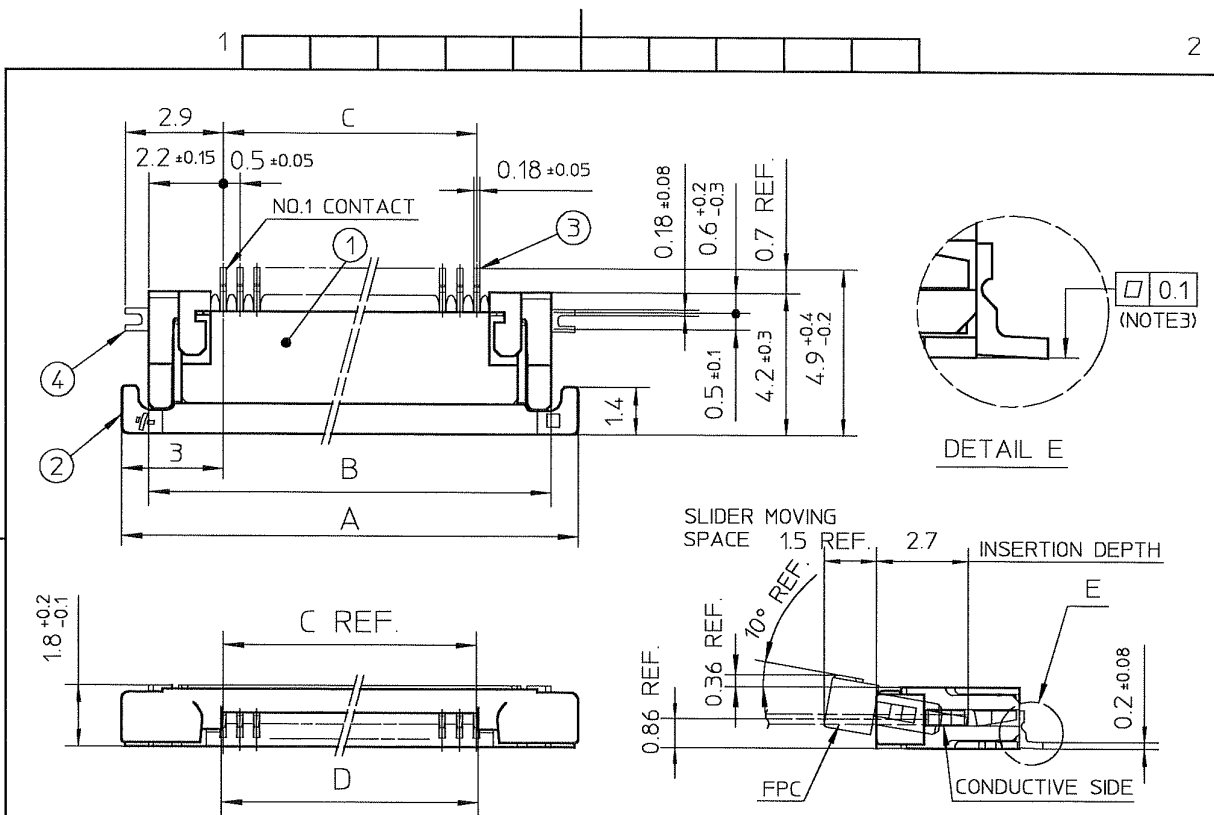

PT. NO.	PARTS NAME	MATERIAL	Q'TY	NOTE
1	HOUSING	POLYAMIDE RESIN GLASS REINFORCED (UL94V-0)	1	COLOR :BLACK
2	SLIDER	PPS RESIN GLASS REINFORCED (UL94V-0)	1	COLOR :BLACK
3	CONTACT	PHOSPHOR BRONZE	n	PLATING :GOLD
4	MOUNTING PLATE		2	PLATING :LEAD FREE

RECOMMENDED PC BOARD LAYOUT  
(COMPONENT SIDE)

PATTERN FOR  
MOUNTING PLATE  
FIXING

n : NO. OF CONTACTS

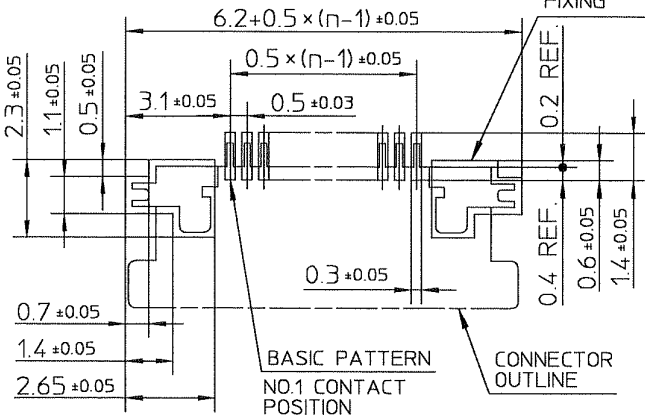

NOTES

- 1.THIS PRODUCT IS THE CONNECTOR USED FOR FPC AND COPE WITH AUTOMATIC MOUNTING (SMT).
- 2.THIS PRODUCT IS LOWER CONTACT TYPE CONNECTOR WITH CABLE LOCK MECHANISM.
- 3.FLATNESS OF CONTACT TERMINAL AND MOUNTING PLATE MUST BE WITHIN TOLERANCE IN E PORTION DETAILED DRAWING.
- 4.THIS PRODUCT MEETS EUROPEAN UNION DIRECTIVES AND OTHER COUNTRY REGULATIONS AS DESCRIBED IN GS-22-008.
- 5.THE HOUSING WILL WITHSTAND EXPOSURE TO 260°C PEAK TEMPERATURE FOR 10 SECONDS IN A REFLOW SOLDERING OVEN.

mat'l. code				surface tolerance ISO 1302 <input checked="" type="checkbox"/> ISO 406 ISO 1101		projection		product family 58EF	
ltr ecn no dr date				tolerances unless otherwise specified		title		CONNECTION USED FOR FPC WITH 0.5 mm CONTACT SPACING (Cat. No. : SFV__R-3STB__LF)	
A J04-0454 H.T '05/2/7				angles linear		scale X		dwg no sheet 1of1 size	
B J05-0710 H.T '05/10/21						FCJ		JSA 96186 A4	
C J06-0064 H.T '06/2/23				dr		type Product Customer Drawing			
D J06-0372 H.T '06/9/7				enr					
				chr					
				appd					
sheet index		revision sheet		D 1				Rev. D	

SC-SFV07 JSA96185  
form: A4

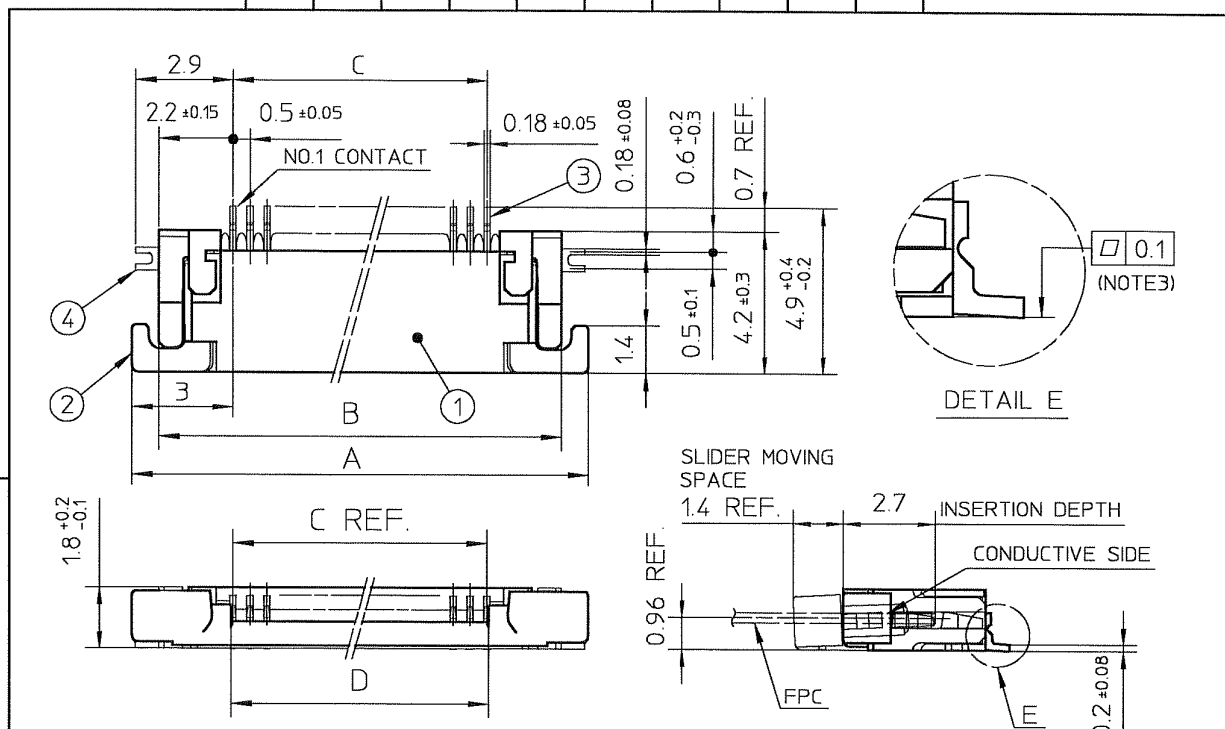

PT. NO.	PARTS NAME	MATERIAL	Q'TY	NOTE
1	HOUSING	POLYAMIDE RESIN GLASS REINFORCED (UL94V-0)	1	COLOR:BLACK
2	SLIDER	PPS RESIN GLASS REINFORCED (UL94V-0)	1	COLOR:BLACK
3	CONTACT	PHOSPHOR BRONZE	n	PLATING:GOLD
4	MOUNTING PLATE		2	PLATING:LEAD FREE

RECOMMENDED PC BOARD LAYOUT (COMPONENT SIDE)

PATTERN FOR MOUNTING PLATE FIXING

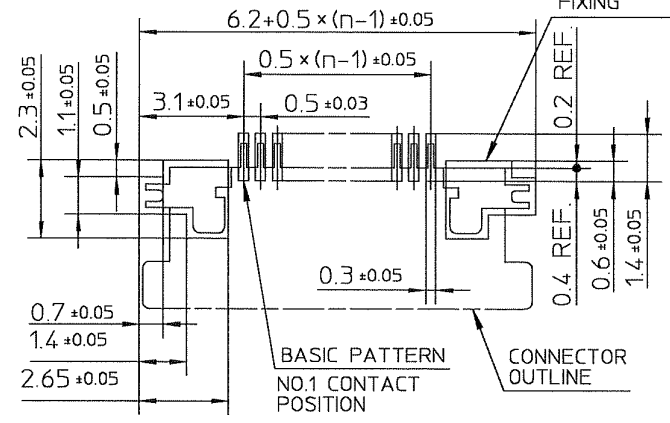

n: NO. OF CONTACTS

NOTES

1. THIS PRODUCT IS THE CONNECTOR USED FOR FPC AND COPES WITH AUTOMATIC MOUNTING (SMT).
2. THIS PRODUCT IS UPPER CONTACT TYPE CONNECTOR WITH CABLE LOCK MECHANISM.
3. FLATNESS OF CONTACT TERMINAL AND MOUNTING PLATE MUST BE WITHIN TOLERANCE IN E PORTION DETAILED DRAWING.
4. THIS PRODUCT MEETS EUROPEAN UNION DIRECTIVES AND OTHER COUNTRY REGULATIONS AS DESCRIBED IN GS-22-008.
5. THE HOUSING WILL WITHSTAND EXPOSURE TO 260°C PEAK TEMPERATURE FOR 10 SECONDS IN A REFLOW SOLDERING OVEN.

mat'l. code				surface ISO 1302 <input checked="" type="checkbox"/>		tolerance ISO 406 ISO 1101		projection		product family 58EF		
ltr	ecn no	dr	date	tolerances unless otherwise specified						title CONNECTOR USED FOR FPC WITH 0.5 mm CONTACT SPACING (Cat. No. : SFV__R-4STB__LF)		
A	J04-0454	H.T	'05/2/7	angles	linear							±0.2
B	J04-0710	H.T	'05/10/21					scale X		dwg no JSA 96187 sheet 1 of 1 size A4		
C	J06-0064	H.T	'06/2/23							type Product Customer Drawing		
D	J06-0372	H.T	'06/9/7	dr	[Signature] 9/9/06 engr [Signature] 9/9/06 chr [Signature] 9/8/06 appd [Signature] 9/9/06					Rev. D		
sheet index		revision sheet	D 1									Rev. D

SC-SFV07 JSA96185 form: A4



FCJconnect.com

Copyright FCJ

CAT. NO. & DIMENSIONS

NO. OF CONTACTS (n)	CAT. NO.	DIMENSIONS (NOTE3)		
		F ± 5	G ± 0.3	H ± 0.1
4	SFV 4R-3/4STBE1LF	20.4	16	—
5	SFV 5R-3/4STBE1LF	20.4	16	—
6	SFV 6R-3/4STBE1LF	20.4	16	—
7	SFV 7R-3/4STBE1LF	28.4	24	—
8	SFV 8R-3/4STBE1LF	28.4	24	—
9	SFV 9R-3/4STBE1LF	28.4	24	—
10	SFV10R-3/4STBE1LF	28.4	24	—
11	SFV11R-3/4STBE1LF	28.4	24	—
12	SFV12R-3/4STBE1LF	28.4	24	—
13	SFV13R-3/4STBE1LF	28.4	24	—
14	SFV14R-3/4STBE1LF	28.4	24	—
15	SFV15R-3/4STBE1LF	28.4	24	—
16	SFV16R-3/4STBE1LF	28.4	24	—
17	SFV17R-3/4STBE1LF	28.4	24	—
18	SFV18R-3/4STBE1LF	28.4	24	—
19	SFV19R-3/4STBE1LF	28.4	24	—
20	SFV20R-3/4STBE1LF	28.4	24	—
21	SFV21R-3/4STBE1LF	28.4	24	—
22	SFV22R-3/4STBE1LF	28.4	24	—
23	SFV23R-3/4STBE1LF	36.4	32	28.4
24	SFV24R-3/4STBE1LF	36.4	32	28.4
25	SFV25R-3/4STBE1LF	36.4	32	28.4
26	SFV26R-3/4STBE1LF	36.4	32	28.4
27	SFV27R-3/4STBE1LF	36.4	32	28.4
28	SFV28R-3/4STBE1LF	36.4	32	28.4
29	SFV29R-3/4STBE1LF	36.4	32	28.4
30	SFV30R-3/4STBE1LF	36.4	32	28.4
31	SFV31R-3/4STBE1LF	48.4	44	40.4
32	SFV32R-3/4STBE1LF	48.4	44	40.4
33	SFV33R-3/4STBE1LF	48.4	44	40.4
34	SFV34R-3/4STBE1LF	48.4	44	40.4
35	SFV35R-3/4STBE1LF	48.4	44	40.4

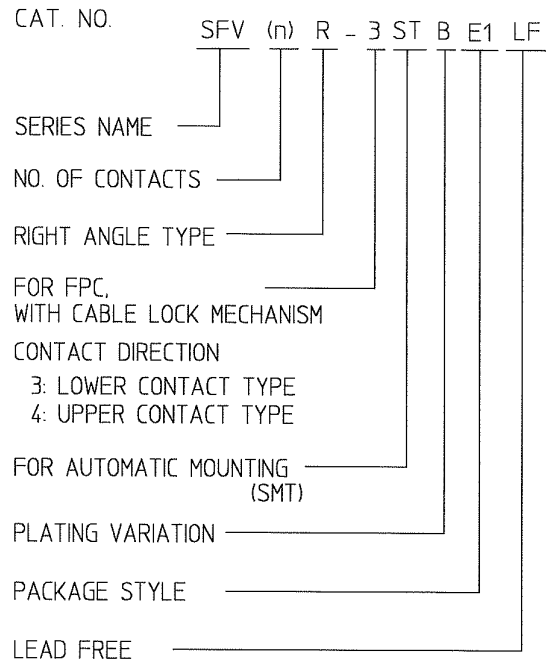

NOTES

1. THIS PRODUCT IS THE CONNECTOR USED FOR FPC AND COPEs WITH AUTOMATIC MOUNTING (SMT).
2. THIS CATALOG NO. INDICATES PLASTIC TAPE PACKAGED
3. SEE PART DRAWINGS FOR DIMENSIONS F-H.
4. THIS PRODUCT IS THE CONNECTOR WITH CABLE LOCK MECHANISM.



FCIconnect.com

Copyright FCI

mat'l. code				surface ISO 1302 <input checked="" type="checkbox"/>		tolerance ISO 406 ISO 1101		projection		product family 58EF	
ltr ecn no dr date				tolerances unless otherwise specified							
A J04-0454 H.T '05/27				angles		linear		scale X		title	
B J06-0372 H.T '06/97										CAT. NO. TABLE FOR PLASTIC TAPE PACKAGED 0.5 mm CONTACT SPACING CONNECTOR (Cat. No. : SFV__R-3/4STBE1LF)	
				dr <i>[Signature]</i> 9/7/06		engr <i>[Signature]</i> 9/9/06		chr <i>[Signature]</i> 9/8/06		appd <i>[Signature]</i> 9/11/06	
				dwg no		sheet 1 of 1		size		JSA 96188 A4	
				type Product Customer Drawing							
sheet index		revision B		sheet 1						Rev. B	

SC-SFV07 JSA96185 96189 96190 form: A4

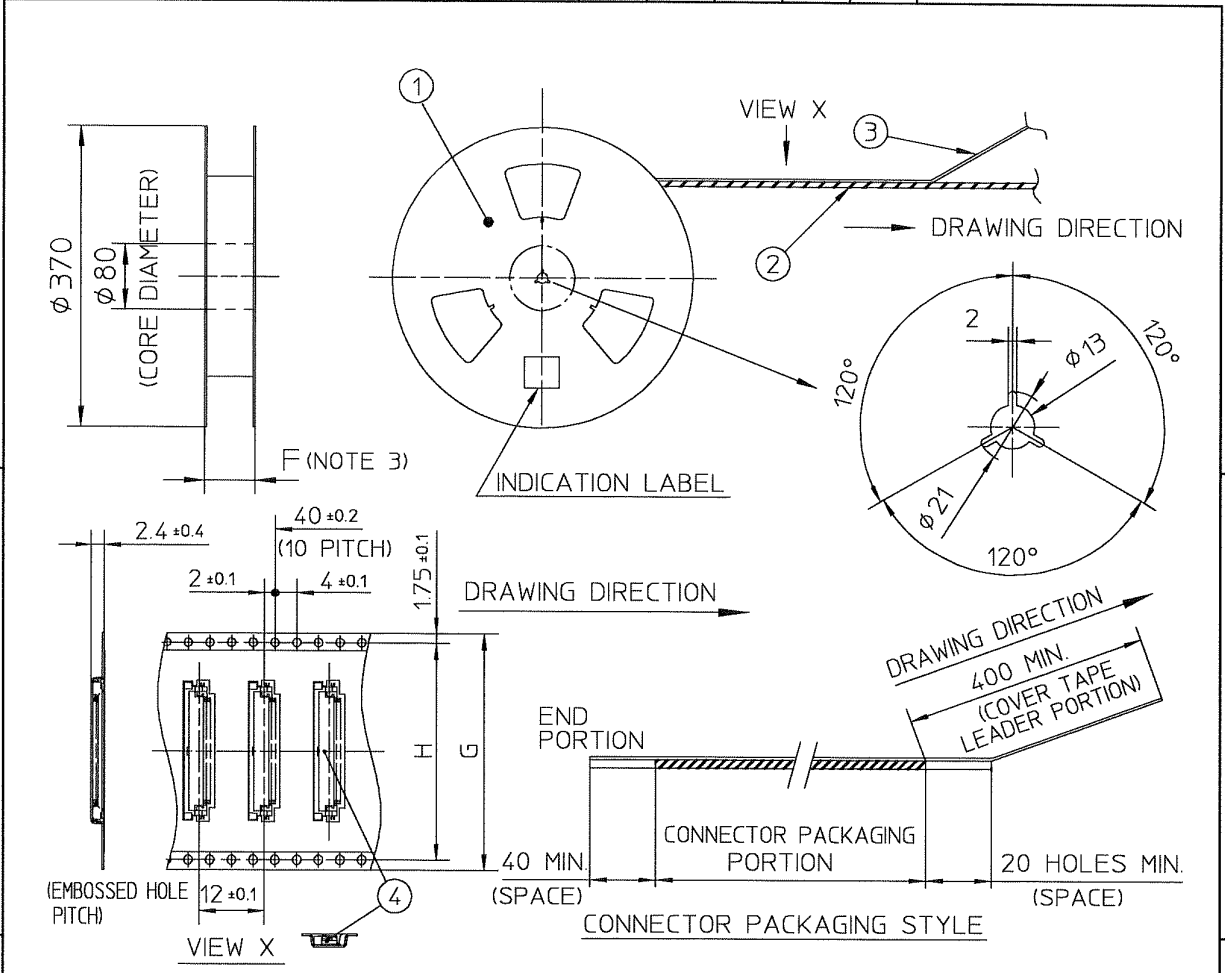

PT. NO.	PARTS NAME	CAT. NO.	MATERIAL	Q'TY	NOTE
1	REEL	---	CARDBOARD	1	COLOR : WHITE
2	PLASTIC (EMBOSS) TAPE	---	A-PET	---	COLOR : TRANSPARENCY
3	COVER	---	POLYESTER	---	COLOR : TRANSPARENCY
4	CONNECTOR	SFV__R-3STB__LF	SEE ATTACHED DWG.	3000	LOWER CONTACT TYPE WITH CABLE LOCK MECHANISM

- NOTES
- THIS IS PLASTIC TAPE PACKAGED CONNECTOR USED FOR FPC AND COPES WITH AUTOMATIC MOUNTING (SMT).
  - SEE JIS C 0806 (PACKING OF ELECTRONIC COMPONENTS ON CONTINUOUS TAPES (SURFACE MOUNTING DEVICES)) FOR SHAPE AND DIMENSIONS OF PLASTIC (EMBOSS) TAPE AND REEL.
  - F DIMENSION IS PORTION OF THE CORE.

mat'l. code				surface ISO 1302 <input checked="" type="checkbox"/> tolerance ISO 406 ISO 1101		projection		product family 58EF		
ltr	ecn no	dr	date	tolerances unless otherwise specified				title		
A	J04-0454	H.T	'05/2/17	±5				PLASTIC TAPE PACKAGED 0.5 mm CONTACT SPACING CONNECTOR (Cat. No. : SFV__R-3STBE1LF)		
B	J06-0372	H.T	'06/9/17	angles	linear			dwg no JSA 96189 sheet 1of1 size A4		
				dr	<i>[Signature]</i>			type Product Customer Drawing		
				enr	<i>[Signature]</i>			Rev. B		
				chr	<i>[Signature]</i>					
				appd	<i>[Signature]</i>					
sheet index	revision sheet	B	1							Rev. B



FCconnect.com

Copyright FCJ

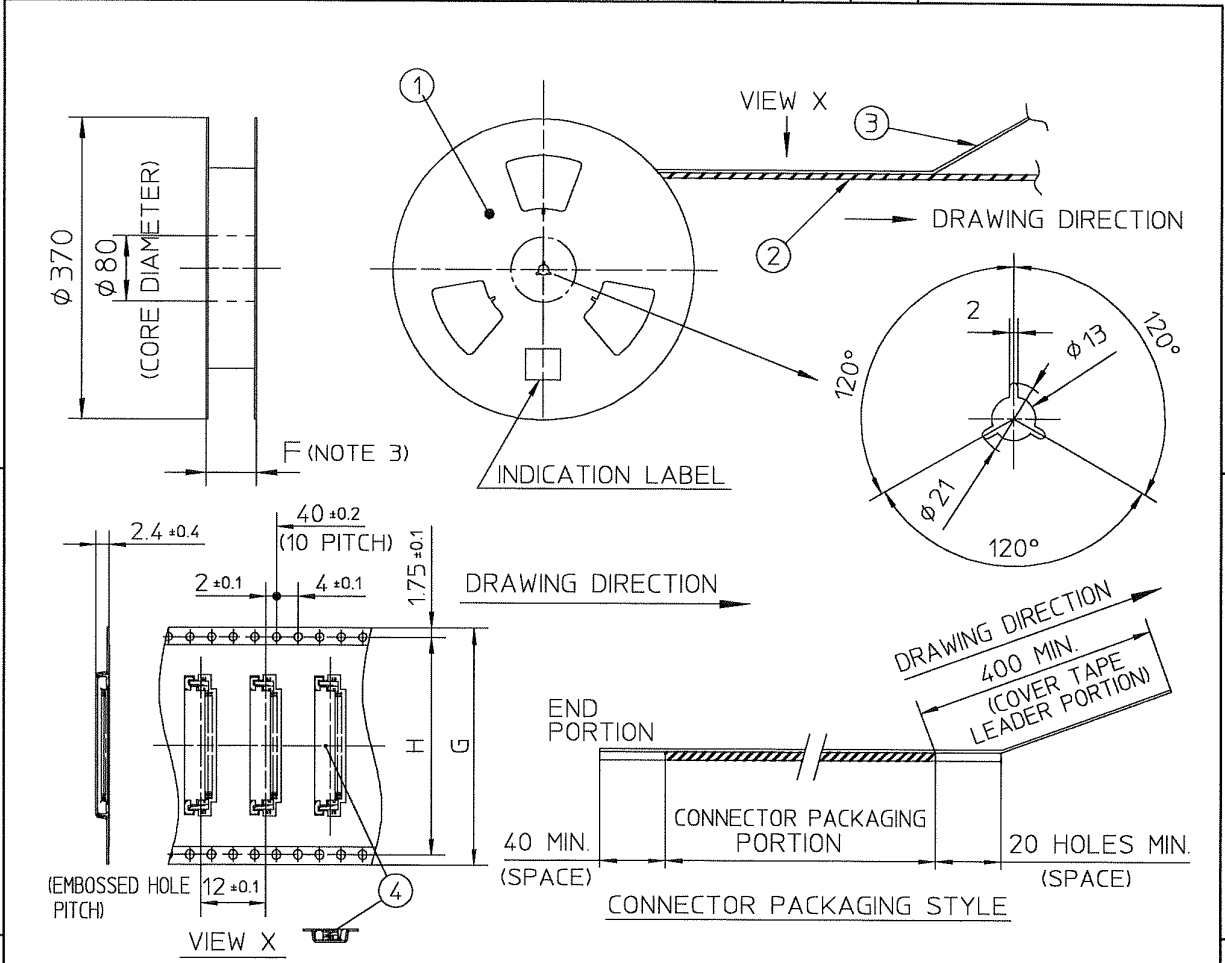

PT. NO.	PARTS NAME	CAT. NO.	MATERIAL	Q'TY	NOTE
1	REEL	_____	CARDBOARD	1	COLOR : WHITE
2	PLASTIC (EMBOSS) TAPE	_____	A-PET	_____	COLOR : TRANSPARENCY
3	COVER	_____	POLYESTER	_____	COLOR : TRANSPARENCY
4	CONNECTOR	SFV__R-4STB__LF	SEE ATTACHED DWG.	3000	UPPER CONTACT TYPE WITH CABLE LOCK MECHANISM

NOTES

1. THIS IS PLASTIC TAPE PACKAGED CONNECTOR USED FOR FPC AND COPES WITH AUTOMATIC MOUNTING (SMT).
2. SEE JIS C 0806 (PACKING OF ELECTRONIC COMPONENTS ON CONTINUOUS TAPES (SURFACE MOUNTING DEVICES)) FOR SHAPE AND DIMENSIONS OF PLASTIC (EMBOSS) TAPE AND REEL.
3. F DIMENSION IS PORTION OF THE CORE.

mat'l. code				surface ISO 1302 <input checked="" type="checkbox"/>		tolerance ISO 406 ISO 1101		projection		product family 58EF	
ltr				ecn no		dr		date		title	
A				J04-0454		H.T		'04/2/7		PLASTIC TAPE PACKAGED 0.5 mm CONTACT SPACING CONNECTOR (Cat. No. : SFV__R-4STBE1LF)	
B				J06-0372		H.T		'06/9/7			
				angles		linear		±5		scale X	
				±5°							
				dr		engr		chr		appd	
										9/7/06 9/7/06 9/8/06 9/11/06	
										FCI dwg no JSA 96190 sheet 1of1 size A4	
										type Product Customer Drawing	
sheet index		revision B		sheet 1						Rev. B	



FCIconnect.com

Copyright FCI

RECOMMENDED CABLE (FPC)

n : NO. OF CONTACTS

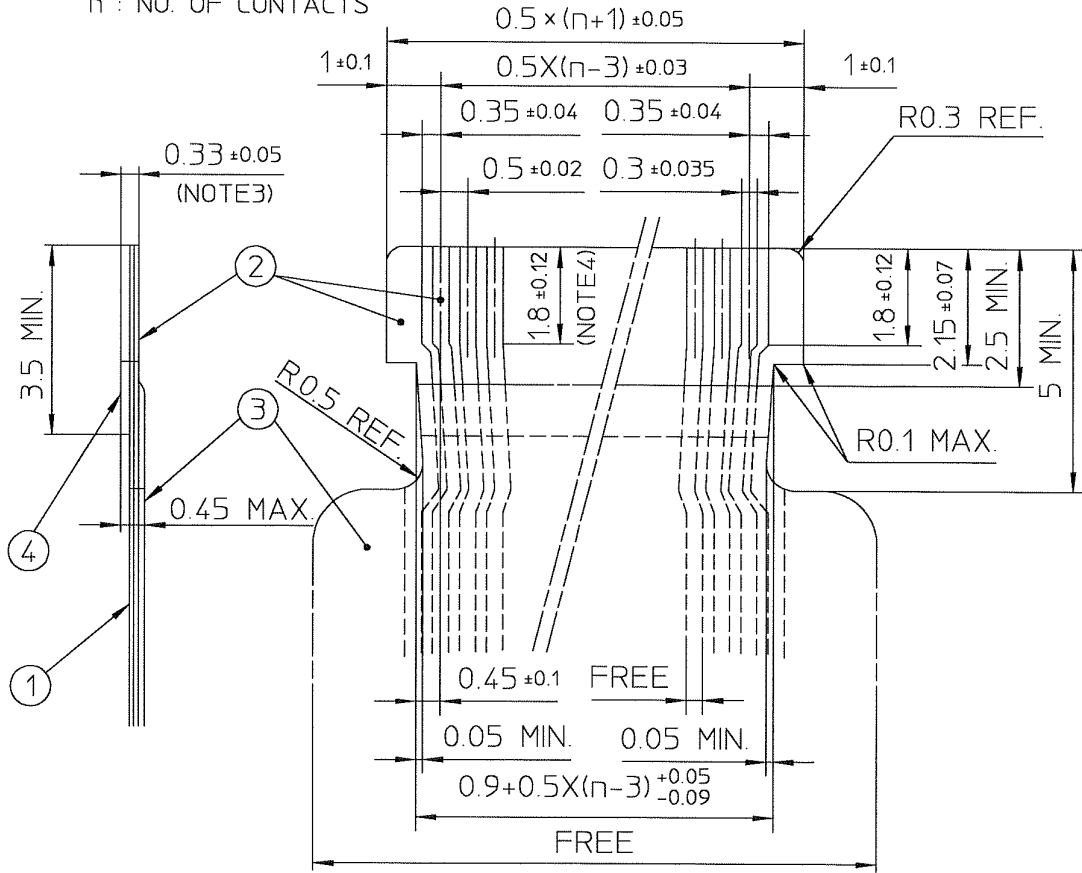

PT. NO.	PARTS NAME	MATERIAL	THICKNESS (μm)
1	BASE FILM	POLYIMIDE OR POLYESTER OR EQUAL	25
2	CONDUCTOR	COPPER FOIL (PLATING : GOLD)	35
3	OVERLAY	POLYIMIDE OR POLYESTER OR EQUAL	—
4	SUPPORTING TAPE	POLYESTER OR POLYIMIDE OR EQUAL	188

NOTES

1. NO BURR AT EACH PORTION.
2. NO PEELING IN COMMON USE.
3. TOTAL THICKNESS LIMIT OF EACH MATERIAL (INCLUDING ADHESIVE AGENT) IS SPECIFIED.
4. THIS DIMENSION INDICATES THE RANGE FOR 0.3 ± 0.035 CONDUCTOR WIDTH.

mat'l. code				surface	tolerance	projection	product family	
				ISO 1302 ✓	ISO 406 ISO 1101		58EF	
ltr	ecn no	dr	date	tolerances unless otherwise specified			title	
A	J04-0454	H.T	'05/2/7	angles	linear	RECOMMENDED CABLE		
B	J06-0372	H.T	'06/9/7				(Cat. No. : SFV__R-3/4ST__LF)	
				dr	engr	chr	appd	scale X
				<i>W. S. S. S.</i>	<i>W. S. S. S.</i>	<i>W. S. S. S.</i>	<i>W. S. S. S.</i>	
				9/9/06	9/9/06	9/8/06	9/9/06	dwg no
								JSA 96191
								sheet 1 of 1
								size
								A4
								type Product Customer Drawing
sheet index	revision sheet	B	1					Rev. B



FCIconnect.com

Copyright FCI