

tyco

Electronics

M Series Pin and Socket Connectors
Catalog 82003 Revised 3-01

AMP

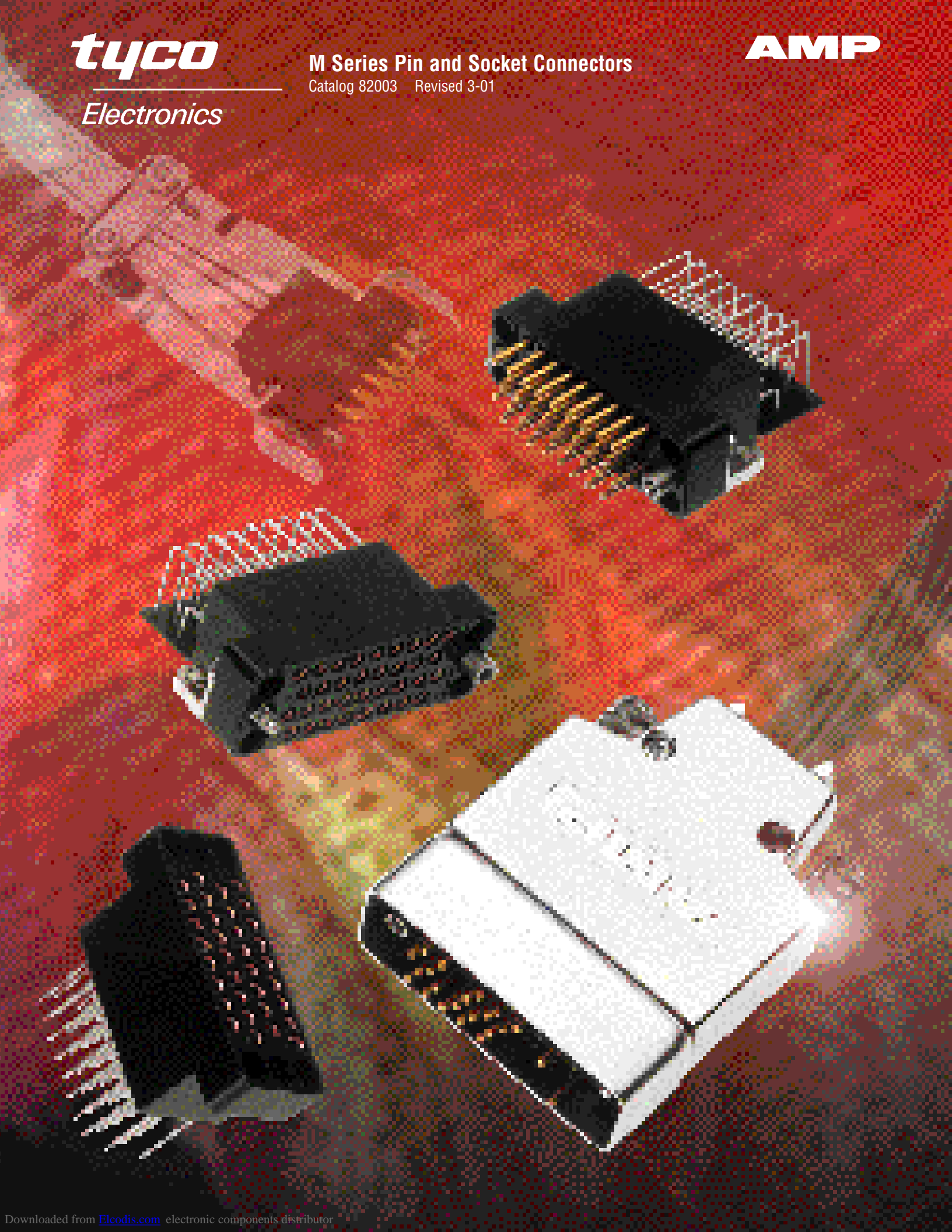

M Series Connectors

Product Facts

- Most connectors intermateable with connectors made to MIL-C-28748 requirements
- Wide range of connector styles and sizes: standard connectors (unloaded), posted connectors (preloaded) and special application connectors (unloaded)
- Complete line of accessory hardware for fastening, protecting, guiding, shielding, strain relief and keying
- A variety of contacts: signal, power, coaxial and posted versions—many are interchangeable and can be intermixed in the same connector housing
- Full complement of application tooling for wire crimp and posted terminations—hand tools, semiautomatic tooling and fully automatic machines provide highly reliable, low cost terminations to meet production requirements

Need More Information?

Call the Technical Support Center:
1-800-522-6752.

The Center is staffed with specialists well versed in all AMP products and application tooling. The Center can provide you with:

- Technical Support
- Catalogs
- Technical Documents
- Product Samples
- AMP FAX Service—Product Information Faxed Immediately
- Authorized Distributor Locations

Specifications subject to change. Consult Tyco Electronics Corporation for latest design specifications.

©1968, 1970, 1972, 1974, 1978, 1985, 1990, 1996 and 2001 by Tyco Electronics Corporation. All Rights Reserved.

AMP, AMP FAX, AMPOMATOR, AMP-O-LECTRIC, AMP-O-MATIC, AMP-TAPETRONIC, CERTI-CRIMP, COAXICON, LGH, POWERBAND, PRO-CRIMPER, RAYCHEM, TERMI-POINT and TYCO are trademarks.

Other products, logos, and company names mentioned herein may be trademarks of their respective owners.

Standard Housings

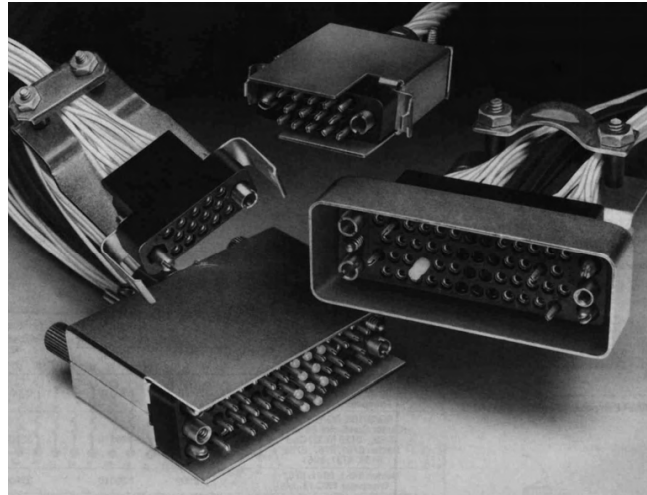

Posted Connectors



Special Application Connectors

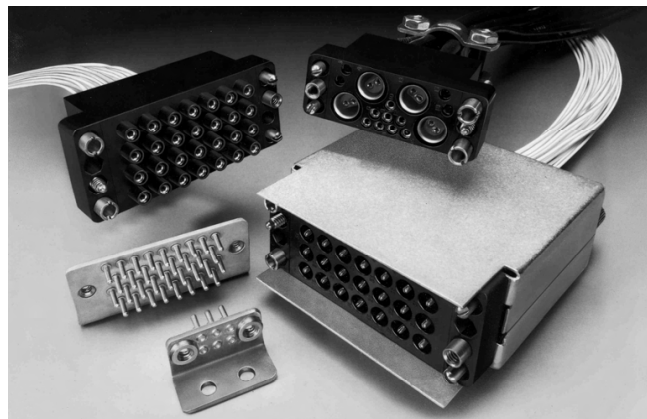

Table of Contents

Product Facts	2
Introduction	4, 5
Material Specifications	6
Current Carrying Capabilities	7, 8
How to Use this Catalog	9
Connector/Hardware Selection Guide (for Typical Applications)	
Cable-to-Cable	10-17
Cable-to-Panel	18-25
Contacts (Description of Types)	26-29
Signal Contacts	
Type II, Crimp, Snap-In	30
Type III+, Crimp, Snap-In; Posted; Solder Versions	31-35
Power Contacts	
Type I, Crimp, Snap-In	36
High Current Type II and Type III+ (Screw Machine, Crimp, Snap-In)	37
Type XII, Crimp, Snap-In	38
High Current Type XII (Screw Machine, Crimp, Snap-In)	39
Coaxial Contacts	
Subminiature, Crimp, Snap-In, Size 16	40, 41
Miniature, Crimp, Snap-In, Size 12	42, 43
Standard Housings—Introduction	44
6, 14, and 20-Positions	45
26, 34 and 36-Positions	46, 47
41 and 50-Positions	47, 48
75 and 104-Positions	49
104 CF Positions (with Center Fastener)	50
160 CF Positions (with Center Fastener)	51
Posted Connectors—Introduction	52
6, 14, 20 and 26-Positions	53, 54
34 and 50 Positions	55, 56
75 and 104-Positions	57
104 and 160 CF Positions (with Center Fastener)	58, 59
15, 36 and 50 Positions (.200 [5.08] Grid)	59, 60
Special Application Connectors—Introduction	61
V.35 Special Application Connectors—Introduction	62, 63
V.35 Printed Circuit Board Connectors	64-67
V.35 Cable Connectors	68-71
12-Positions, High Current Connector (UL Voltage Rating: 1800 V)	72
29 CF Position Connector with Mixed Contacts (with Center Fastener)	73
42-Positions, Connector with Mixed Contacts	74
20-Positions, High Voltage Connector (UL Voltage Rating: 1800 V)	75
28-Positions, High Voltage Connector (UL Voltage Rating: 1800 V)	76
14 and 34-Positions, Grounding Blocks and Fastening Hardware	77
Hardware	
Fastening Hardware	78-80
Guiding Hardware	81
Protective Hardware	82-87
Strain Relief Hardware	88
Keying Hardware	89
Application Tooling	90, 91
Technical Documents	92, 93
Part Number Index	94, 95

Introduction

AMP M Series connectors are one of the most versatile and complete pin and socket connector lines available today.

From the basic molded plastic housing, a connector can be built up with a wide choice of contacts and hardware to serve in applications ranging from sophisticated computers, medical instrumentation and military ground support equipment to rugged truck transmissions.

How this M Series catalog is divided

The M Series catalog is divided into six categories:

- Application section
- Contacts/Tooling
- Standard Connector Housings
- Posted Connector Housings
- Special Application Connector Housings
- Hardware

Following is a brief summary of each of the six categories.

Knowing what you need to meet your application is made easy

Eight applications have been illustrated with selection charts from pages 10 through 25. These charts will assist you to select the appropriate connector housing as well as the necessary hardware. Each base part number is listed in the numerical index on pages 94, 95 in order to find complete information about a particular part.

Contacts of various types provide different functions in M Series connector housings

Included are contacts for signal and power applications, for coaxial cable and posted versions for backpanel wiring. A full complement of application tooling is available to meet any production requirement for terminating the crimp-type contacts and wiring

posted contacts. A description of each contact type is presented on pages 26 through 29. Application tooling for these contacts is described on pages 90 and 91.

Standard connectors

Standard connectors are comprised of unloaded housings that accept a variety of crimp, solder and posted contacts. All standard connector housings will accept pins and/or sockets, permitting various combinations of contact loading. Standard connectors are described on pages 44 through 51.

Posted connectors

Posted connectors are preloaded with post-type contacts that accept TERMI-POINT Clip or wrap-type terminations. All posted connectors are described on pages 52 through 60.

Special Application connectors

Connectors for special application are available in the following configurations:

- V.35
- High Current
- Mixed Contact Connectors
- High Voltage
- RFI/EMI Shielded
- Grounding Blocks

Special Application Connectors are described on pages 61 through 77.

The right hardware for the entire M Series connector line

Hardware is available to provide fastening, protection, shielding, guiding, strain relief and keying capabilities for the entire M Series connector line. Application charts for properly selecting hardware are presented on pages 10 through 25. Detailed information on hardware is located on pages 78 through 89.

Introduction (Continued)**What makes the M Series connector line so versatile and special for a wide variety of applications?**

- **Compatibility**—Most connectors intermateable with connectors made to MIL-C-28748 requirements.
- **Wide range**—Choice of connector styles and sizes: standard connectors (unloaded), posted connectors (preloaded) and special application connectors.
- **Complete line**—Full line of accessory hardware for fastening, protecting, guiding, strain relief and keying.
- **Variety of contacts**—Signal, power, coaxial, and posted versions—many are interchangeable and can be intermixed in the same connector housing.
- **Full complement of application tooling**—For wire crimp and posted terminations hand tools, semiautomatic tooling and fully automatic machines provide highly reliable, low cost terminations to meet production requirements.

How to choose the appropriate connector/contact/hardware combination

Choosing the appropriate connector/contact/hardware combination is essential to the proper function of any AMP M Series connector. First, a customer must evaluate each individual application with regards to: wire size(s); number of circuits; available space; fastening methods; and needs for protection, shielding, guiding, strain relief and keying. Then, the customer must consider the following factors to make the appropriate selection of M Series connectors and related components.

A—Determine Connector Type—

This decision is based on the selected contact types, circuit density requirements and, if posted connectors are desired, in-plant production capabilities for wiring connectors using hand tools or semiautomatic tooling. Detailed specifications of the various M Series connectors are presented on the following pages: Standard connectors (pages 44 through 51), Posted connectors (pages 52 through 60), Special Application connectors (pages 61 through 77).

B—Determine Hardware—

This decision is based on the selected connector types, and the individual application requirements for fastening, protection, shielding, guiding, strain relief and keying. To assist customers in determining the proper hardware to use, hardware selection information has been formulated for each connector type. This information is located on pages 10 through 25. Complete specifications of each hardware component are presented in the Hardware section of the catalog (pages 78 through 89).

C—Determine Contact Type—

This decision is based on wire size(s) and reliability and cost requirements of an application, as well as the customer's in-plant production capabilities. Complete specifications, including accepted wire sizes and available platings of all pin and socket contacts, are presented in the Contacts section of the catalog (pages 30 through 43). Application tooling for crimp- and post-type contacts is presented on pages 90 and 91).

Material Specifications

Contacts

The material composition and construction of AMP contacts encompass varying price ranges and performance characteristics. Specific materials and available platings and plating thicknesses of each contact type are provided on individual contact pages in the Contact section (pages 30 thru 43). A brief description of each contact type is presented on pages 26 through 29. Also, typical performance data of M Series connectors and contacts is shown below.

Housings

M Series connector housings are made of either diallyl phthalate (blue), general purpose phenolic (black) or polyester (black).

Diallyl phthalate housings are molded of material per MIL-M-14, Type SDG. These housings are ideally suited for use where adverse environmental conditions are an important factor. Their advantages include exceptional stability; excellent resistance to acids, alkalies and solvents; low moisture absorption; and good dielectric strength.

Phenolic housings are molded of material per MIL-M-14, Type CFG. The performance characteristics of these housings make them an excellent choice for applications in which exceptional resistance to acids, alkalies or solvents is not of prime concern. Polyester housings are molded from a high temperature thermoplastic material per ASTM D3220. Polyester housings provide the high temperature characteristics of diallyl phthalate and phenolic, but with a higher impact strength.

Hardware

A variety of materials such as plated steel, stainless steel and aluminum, are used in the construction of M Series connector hardware. This provides for the proper operation and durability of each hardware component, while offering a choice of economies to satisfy particular application requirements. The materials of each hardware component are specified on the individual hardware component pages in the Hardware section (pages 78 through 89).

Performance Data

Temperature Rating:

Phenolic Housings,
-55°C to +150°C
Diallyl Phthalate Housings,
-65°C to +125°C
Polyester, -55°C to +130°C

Flammability Ratings: UL94V-0

Dielectric Withstanding

Voltage (at sea level):

Type II Contacts, 1500 VAC, RMS
Type III+ Contacts, 900 VAC, RMS

Durability (Mating/Unmating):

Types II and III+ Contacts,
Gold Plated: 500 cycles;
Types II and III+ Contacts,
Bright Tin-Lead Plated:
50 cycles; Type I Contacts,
Gold Plated: 100 cycles

Note: For detailed information on the above performance data and further information on other performance data such as Insulation Resistance, Thermal Shock, Moisture Resistance, Vibration and Physical Shock, request AMP Product Specification No. 108-10001.

■ Recognized under the
Component Program of
Underwriters Laboratories
Inc. for 250 volts,
File No. E28476



■ Certified by Canadian
Standards Association,
File No. LR 7189



Current Carrying Capabilities

The total current capacity of each contact in a given connector is dependent upon the heat rise resulting from the combination of electrical loads of the contacts in the connector arrangement and the maximum ambient temperature in which the connector will be operating. Caution must be taken to ensure that this combination of conditions does not cause the internal temperature of the connector to exceed the maximum operating temperature of the housing material. Several variables which must be considered when determining this maximum current capability for your application are:

■ **Wire Size**—Larger wire will carry more current since it has less internal resistance to current flow and generates less heat. The wire also conducts heat away from the connector.

CONTACT CURRENT GUIDE Maximum Current (Amperes)

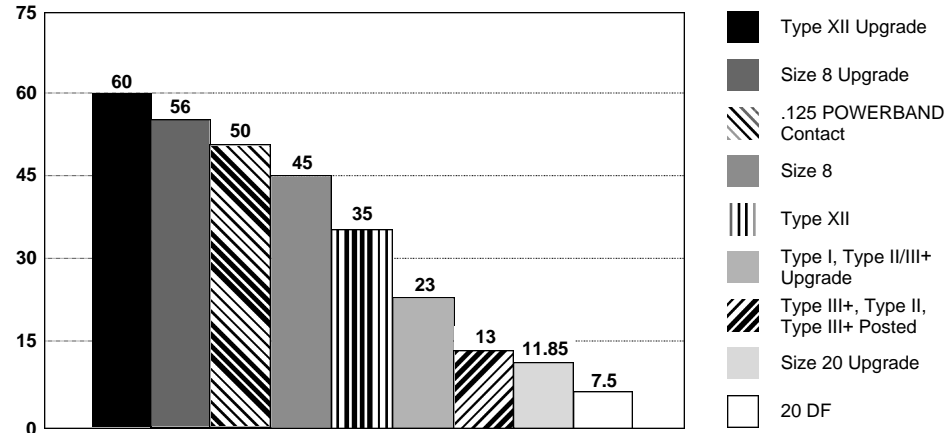

■ **Connector Size**—In general, with more circuits in a connector, less current per contact can be carried.

■ **Current Load Distribution**—Spreading those lines with greater current loads throughout the connector, particularly around the outer perimeter, will enhance heat dissipation.

■ **Ambient Temperature**—With higher ambient temperatures, less current can be carried.

Current Rating Verification
Can a contact rated at 10 amps carry 10 amps?

Maybe yes, but probably not. The reason lies in the test conditions used to rate the contact. If these conditions do not adequately reflect the application conditions, the actual allowable current levels may be lower than specified levels. For example, many manufacturers, including Tyco, test a single contact in air. This gives an accurate measure of the basic current-carrying capacity of the contact. Use the contact alone in air and it can certainly carry 10 amperes. Use it in a multi-position connector surrounded by other current-carrying contacts or in high ambient temperatures, and the contact should carry less current.

Similarly, as the contact ages and stress relaxation, environmental cycling, and other degradation factors take their toll, the contact's current-carrying capacity decreases. A prudent design must set current levels for such end-of-design-life (EODL) conditions.

Practical current-carrying capacity is not an absolute, but an application-dependent condition.

New Method Simplifies Ratings

To help the designer set the appropriate current level, Tyco has developed a method of specifying current-carrying capacity. This method takes into account the various application factors that influence current rating.

The method can be summarized as follows:

- The contact is aged to EODL conditions by durability cycling, thermal cycling, and environmental exposure.
- The contact's resistance stability is verified.
- The current necessary to produce the specified temperature rise is measured. This T-rise is usually 30°C.
- A rating factor is determined to allow derating of multiple contacts in the same housing and for different conductor sizes.

Temperature

One other factor influencing current levels is the maximum operating temperature, for example, 105°C. If the application has a high ambient temperature (over 75°C) the contact's T-rise is limited by the maximum operating temperature. For example, an application temperature of 90°C limits the contact T-rise to 15°C. Since current produces heat (the I²R law), the current must be lowered to limit the T-rise.

A contact's T-rise depends not only on its I²R Joule heating, but also on its ability to dissipate the heat. Consider a contact in a multi-contact housing. Joule heating in multiple contacts will raise the local ambient temperature. Since the contact will not be able to dissipate its own heat as well by convection, the maximum T-rise will be realized at a lower current level. Consequently, the allowable current level must be lower to maintain an acceptable T-rise.

For a given connector, the current level will be set by the loading density. A connector

containing 50% current-carrying contacts will permit higher currents (per contact) than a connector will at 75% loading. The loading percentage assumes an even distribution of contacts within the housing. If all 10 contacts are grouped together in one section of a 20-position connector, the loading density may approach 100%.

The Importance of EODL

As stated, T-rise in a contact depends on both resistance and current. As it ages, a contact's resistance will increase. The contact designer will specify a maximum resistance for the contact, this level is the end-of-design-life resistance. Before the contact is tested for current, Tyco subjects it to a sequence of tests that exercises the major failure mechanisms and thereby simulates EODL conditions. Conditioning includes mating cycling, industrial mixed-flowing gases, humidity and temperature cycling, and vibration to sequentially introduce wear, corrosion, stress relaxation, and mechanical disturbance.

Dimensions are shown for reference purposes only.

Dimensions are in inches and millimeters unless otherwise specified. Values in brackets are metric equivalents.

Specifications subject to change.

Technical Support Center
1-800-522-6752
www.tycoelectronics.com

Presentation—Example of New Current Rating Format

The presentation of current-carrying capacity in AMP product specifications includes two parts:

- First, a base curve showing current levels versus T-rise for a single circuit and the largest wire size (See figure 1). This represents the maximum current capacity of the contact. The curve is usually flat up to 75°C ambient and then drops off. Up to 75°C, the 30°C T-rise limits the amount of current, and above 75°C the current must be reduced to keep the combination of ambient temperature and T-rise from exceeding the maximum operating temperature of 105°C.
- Next are rating factors; a table of multipliers to account for connector loading and for smaller wire sizes (See figure 2). The designer first determines the base current for the ambient conditions of the application; then multiplies this base current by the rating factors to find the current level for the application's loading factor and wire size.

Practical Values

The current-rating method gives designers practical values applicable to their applications. While the specified current levels for a contact may be lower than for other testing methods, they are more realistic and simplify the system design process.

"Spec-manship" is replaced by a realistic assessment of the current-carrying capacity of a

Connector/Contact Acceptability

As previously stated, choosing the appropriate connector/contact combination is fundamental to the successful function of all connectors. The Selection Chart, shown at right, is designed to simplify your choice of connectors and their acceptable contacts. Once you have selected the wire size, current-carrying capacity need, number of positions required, and the type of contacts needed in your choice of connector, refer to this matrix for a quick look at exactly what is acceptable in a given connector type.

Note: Data is *not* typical of a specific M Series connector configuration. For specific current rating information based on % connector loading, contact Tyco Electronics.

To demonstrate the method of specifying current, consider the following application conditions; an ambient temperature of 65°C, a 50% loading of contacts in the housing, and 20 AWG [0.6mm²] wire.

- From Figure 1, the base current rating is 14 ampere with 18 AWG [0.8mm²] wire.
- Figure 2, the rating factor for 50% loading and 20 AWG [0.6mm²] wire is 0.68.
- The specific rating for this application is the product of the base rating and the rating factor:
 $14 \times 0.68 = 9.5$ ampere
- Each of the contacts can carry 9.5 ampere.
- However, if the ambient temperature is 80°C the allowable T-rise becomes 25°C. The base current must be lowered to 12.8 ampere so that the 105°C maximum operating temperature is not exceeded. The current rating then becomes:
 $12.8 \times 0.68 = 8.7$ ampere.

contact under varying conditions of temperature, connector loading, and wire size.

Specific current-carrying data based on EOL and % loading is available from Tyco Electronics Corporation. Please contact your local Sales Engineer or call Tyco Electronics Corporation.

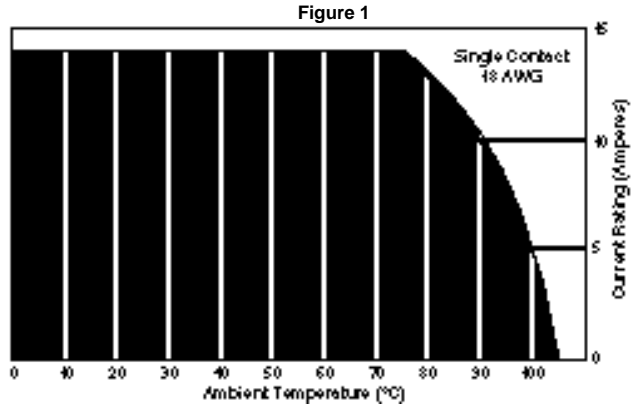

Graph shows the relationship between base current, ambient temperature, and contact T-rise.

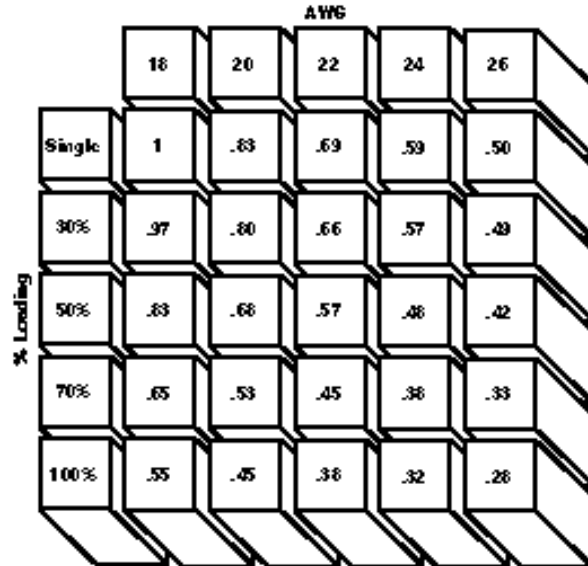

Rating factors allow the base current to be adjusted for various connector loading and wire sizes.

Contact Selection Chart

Connector Type	Type I	Type II	High Current Type II/III+	Type III+	Posted Type III+	Type XII	High Current Type XII	Mini-Coax	Sub-Mini Coax
M Series		✓	✓	✓	✓				✓
M Series Special	✓	✓	✓	✓	✓	✓	✓	✓	✓

How to Use the M Series Connector Catalog

The information in this catalog has been arranged to assist the customer in selecting the connector and associated hardware that best satisfies their requirements.

Four cable-to-cable and four cable-to-panel applications utilizing the various types of fastening, guiding and protective hardware have been illustrated on pages 10 through 25.

After selecting the appropriate application to fit a particular requirement, refer to the indicated pages for component selection.

Posted connectors and Special Application connectors can be substituted for Standard Connectors where

indicated. Noted under each Special Application Connector is the standard size hardware used for that connector. Substitute into the appropriate column of the component selection charts.

The main portion of the catalog is divided into five basic sections: contacts, standard connectors, posted connectors, special application connectors and hardware. These sections contain brief descriptions, dimensions and other technical information. The remainder of the catalog contains application tooling information, a technical documents list and a numerical index which references pages covering all cataloged part numbers.

Cable-to-Cable

Application

A

Featured Hardware

- Strain Relief Clamps
- Locking Springs
- Pin Hoods
- Guide Hardware

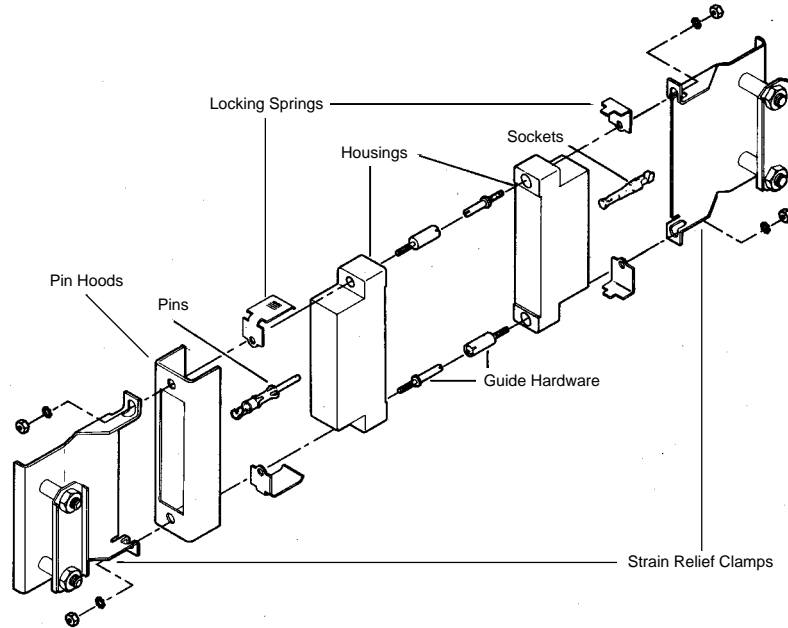

Component Description		Number of Positions				
		6	14	20	26	34
STANDARD HOUSINGS Pages 44 to 51	Plug Block Receptacle Block } Phenolic	202758-1	201355-1	201356-1	201359-1	1-201357-1
		202757-1	201298-1	200346-2	200512-2	200838-2
	Plug Block Receptacle Block } Diallyl Phthalate	202758-3	—	201356-3	201359-3	201357-3
		202757-3	201298-3	200346-4	200512-3	200838-3
Plug Block Receptacle Block } Polyester	—	—	—	—	2013800-1	
	—	—	—	—	200802-1	
STRAIN RELIEF CLAMPS Page 88	Long } Nickel Plated Steel	—	201843-1	—	201845-1	201846-1
		203432-1	200686-1	—	201229-1	—
	Long } Stainless Steel	—	—	—	—	—
		—	—	201237-1	—	201224-1
GUIDE HARDWARE Page 81	Center Male	200389-2	200389-2	200389-2	200389-2	200389-2
	Center Female	200390-2	200390-2	200390-2	200390-2	200390-2
	Corner Male	—	—	—	—	200833-2
	Corner Female	—	—	—	—	200835-2
	—	—	—	—	—	—
LOCKING SPRINGS¹ Page 80	Male—Nickel Plated Spring Steel	201921-1	201921-1	201921-1	201923-1	201925-1
	Female—Stainless Steel	201922-1	201922-1	201922-1	201918-1 (Single Spring)	201926-1
PIN HOODS Pages 82 and 83	Internal Open End	Nickel Plated Steel	204258-6	201363-4	—	201785-4
	Internal Closed End	Nickel Plated Steel	—	—	—	—
	External Closed End	Al Iridite	—	—	—	—
	External Closed End	Nickel Plated Steel	—	—	—	—

¹Each part number contains two locking springs. Order one male and one female for each mated pair of connectors.

Cable-to-Cable (Continued)

1. Confirm that **Application A** (at left) most closely meets your requirements. (Other applications are shown on pages 12 through 25.)
2. Find the appropriate column for the number of positions required.
3. Select part numbers required for the application listed in the column below the number of positions.

If a part number is not listed for a particular item, it is not available.

If more than one part number is listed for a particular hardware item, choose the one which best fits your application.
4. Dimensional information is available on the indicated pages under description column.
5. Select Contacts: Type II (page 30), Type III+ (pages 31 through 35) or Subminiature Coaxial (pages 40, 41).

Special application housings may be substituted for these standard housings. See Special Application Section.

This cable-to-cable application utilizes locking springs, strain relief clamps, a pin hood for pin protection and guide hardware.

The 34 and 50 position connectors can be used with either center or corner guide hardware. If center guide hardware is used, an additional four 4-40 screws, nuts and lockwashers are required to secure the locking springs. Corner guides require four guide pins and four guide sockets for each mated pair of connectors.

Number of Positions						Component Description		
41	50	75	104	104 CF	160 CF			
202135-2	201358-1	—	—	—	—	Plug Block Receptacle Block	Phenolic	STANDARD HOUSINGS Pages 44 to 51
201302-1	200277-2	—	—	—	—			
202135-4	201358-3	—	—	—	—	Plug Block Receptacle Block	Diallyl Phthalate	
201302-3	200277-4	—	—	—	—			
—	—	—	—	1-201692-6	—	Plug Block Receptacle Block	Polyester	
—	—	—	—	—	—			
—	—	—	—	—	—	Long Short	Nickel Plated Steel	
—	201182-1	—	—	—	—			
201766-1	201847-1	—	—	—	—	Long Short	Stainless Steel	
—	—	—	—	—	—			
200389-2	200389-2	—	—	—	—	Center Male Center Female Corner Male Corner Female	Stainless Steel	
200390-2	200390-2	—	—	—	—			
—	200833-2	—	—	—	—			
—	200835-2	—	—	—	—			
201921-1	201925-1	—	—	—	—	Male—Nickel Plated Spring Steel	LOCKING SPRINGS¹ Page 80	
201922-1	201926-1	—	—	—	—	Female—Stainless Steel		
—	—	—	—	—	—	Internal Open End		
—	—	—	—	—	—	Internal Closed End	PIN HOODS Pages 82 and 83	
—	—	—	—	—	—	External Closed End		
—	—	—	—	—	—	External Closed End		
—	—	—	—	—	—	External Closed End	Nickel Plated Steel	

Dimensions are shown for reference purposes only.

Dimensions are in inches and millimeters unless otherwise specified. Values in brackets are metric equivalents.

Specifications subject to change.

Technical Support Center
1-800-522-6752
www.tycoelectronics.com

Cable-to-Cable (Continued)

Application

B

Featured Hardware

- Strain Relief Clamps
- Pin Hoods
- Jackscrews
- Guide Hardware

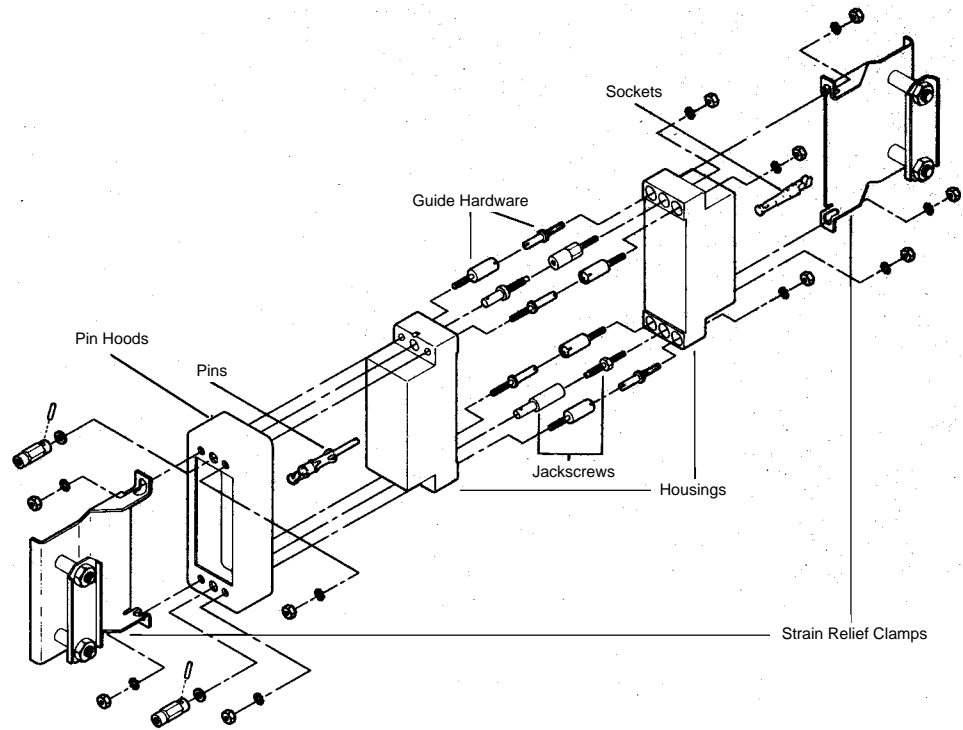

Connector/Hardware Selection Guide

Component Description		Number of Positions					
		6	14	20	26	34	
STANDARD HOUSINGS Pages 44 to 51	Plug Block Receptacle Block } Phenolic	202758-1	201355-1	201356-1	201359-1	1-201357-1	
		202757-1	201298-1	200346-2	200512-2	200838-2	
	Plug Block Receptacle Block } Diallyl Phthalate	202758-3	—	201356-3	201359-3	201357-3	
		202757-3	201298-3	200346-4	200512-3	200838-3	
Plug Block Receptacle Block } Polyester	—	—	—	—	213800-1		
	—	—	—	—	213802-1		
STRAIN RELIEF CLAMPS Page 88	Long } Nickel Plated Steel	—	201843-1	—	201845-1	201846-1	
		203432-1	200686-1	—	201229-1	—	
	Long } Stainless Steel	—	—	—	—	—	
		—	—	201237-1	—	201224-1	
JACKSCREWS¹ Pages 78 and 79	Fixed Male Fixed Female } Stainless Steel	201092-1	201092-1	201092-1	201092-1	201092-1	
		201089-1	201089-1	201089-1	201089-1	201089-1	
	Long-Long Male Long-Long Female Long Male Long Female Short-Short Male Short-Short Female } Tip: Stainless Steel Body: Die Cast Zinc	—	—	—	—	—	
		—	—	—	—	—	
		—	—	—	—	—	
		201827-1	201827-1	201827-1	201827-1	201827-1	
		201828-1	201828-1	201828-1	201828-1	201828-1	
		—	—	—	—	—	
GUIDE HARDWARE Page 81	Center Male Center Female } Stainless Steel	—	—	—	—	—	
		—	—	—	—	—	
	Corner Male Corner Female }	—	—	—	—	200833-2	
		—	—	—	—	200835-2	
PIN HOODS Pages 82 and 83	Internal Open End	Nickel Plated Steel	204258-6	201363-4	—	201785-4	201786-4
	Internal Closed End	Nickel Plated Steel	—	—	—	—	202434-4
	External Closed End	Al Iridite	—	—	—	201349-2	201350-2
	External Closed End	Nickel Plated Steel	—	—	—	—	—

¹Listed Jackscrews have 6-32 single lead threads. For corresponding Jackscrews with 6-32 double lead threads, refer to pages 78 and 79.

Cable-to-Cable (Continued)

1. Confirm that **Application B** (at left) most closely meets your requirements. (Other applications are shown on pages 10-11 and 14 through 25.)
2. Find the appropriate column for the number of positions required.
3. Select part numbers required for the application listed in the column below the number of positions.

If a part number is not listed for a particular item, it is not available.

If more than one part number is listed for a particular hardware item, choose the one which best fits your application.
4. Dimensional information is available on the indicated pages under description column.
5. Select Contacts: Type II (page 30), Type III+ (pages 31 through 35) or Subminiature Coaxial (pages 40, 41).

Special application housings may be substituted for these standard housings. See Special Application Section.

This cable-to-cable application utilizes jackscrews, strain relief clamps and guide hardware. A pin hood is provided for pin protection. Sizes 6, 14, 20, 26, and 41 **do not** use guide hardware with this application.

Number of Positions						Component Description		
41	50	75	104	104 CF	160 CF			
202135-2	201358-1	201310-1	201345-1	—	—	Plug Block Receptacle Block	Phenolic	STANDARD HOUSINGS Pages 44 to 51
201302-1	200277-2	201311-1	201037-1	—	—			
202135-4	201358-3	201310-3	201345-2	—	—	Plug Block Receptacle Block	Diallyl Phthalate	
201302-3	200277-4	201311-3	—	—	—			
—	—	—	—	1-201692-6	—	Plug Block Receptacle Block	Polyester	
—	—	—	—	—	—			
—	—	—	201849-1	—	—	Long Short	Nickel Plated Steel	
—	201182-1	200730-1	—	—	—			
201766-1	201847-1	201848-1	—	—	—	Long Short	Stainless Steel	
—	—	—	—	—	—			
201092-1	201092-1	201092-1	201092-1	—	—	Fixed Male Fixed Female	Stainless Steel	
201089-1	201089-1	201089-1	201089-1	—	—			
—	—	—	—	—	—	Long-Long Male Long-Long Female Long Male Long Female Short-Short Male Short-Short Female	Tip: Stainless Steel Body: Die Cast Zinc	JACKSCREWS¹ Pages 78 and 79
—	—	—	—	—	—			
—	—	—	—	—	—			
201827-1	201827-1	201827-1	201827-1	—	—			
201828-1	201828-1	201828-1	201828-1	—	—			
—	—	—	—	—	—	Center Male Center Female Corner Male Corner Female	Stainless Steel	GUIDE HARDWARE Page 81
—	200833-2	201046-2	201046-2	—	—			
—	200835-2	201047-2	201047-2	—	—			
—	—	—	—	—	—	Internal Open End Internal Closed End	Nickel Plated Steel	PIN HOODS Pages 82 and 83
—	202394-2	201369-4	201364-4	—	—			
—	—	—	—	—	—	External Closed End	Al Iridite	
—	201390-5	201368-4	201346-4	—	—			
—	—	—	—	—	—	External Closed End	Nickel Plated Steel	

Dimensions are shown for reference purposes only.

Dimensions are in inches and millimeters unless otherwise specified. Values in brackets are metric equivalents.

Specifications subject to change.

Technical Support Center
1-800-522-6752
www.tycoelectronics.com

Cable-to-Cable (Continued)

Application

C

Featured Hardware

- Shields (One-piece)
- Pin Hoods
- Locking Springs
- Guide Hardware

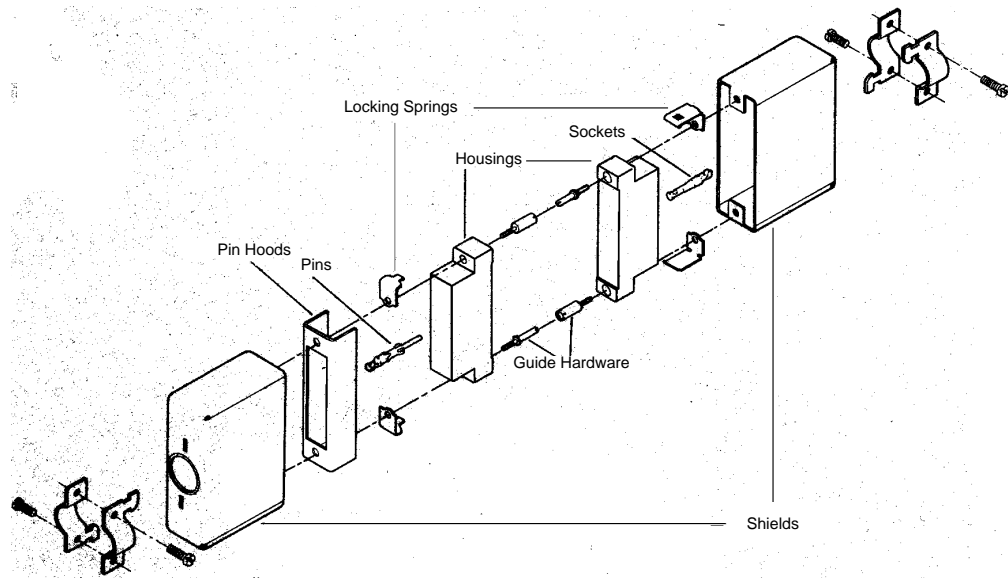

Connector/Hardware Selection Guide

Component Description	Number of Positions					
	6	14	20	26	34	
STANDARD HOUSINGS Pages 44 to 51	Plug Block Receptacle Block } Phenolic	—	201355-1	201356-1	201359-1	1-201357-1
		—	201298-1	200346-2	200512-2	200838-2
	Plug Block Receptacle Block } Diallyl Phthalate	—	—	201356-3	201359-3	201357-3
		—	201298-3	200346-4	200512-3	200838-3
Plug Block Receptacle Block } Polyester	—	—	—	—	213800-1	
	—	—	—	—	213802-1	
SHIELDS Pages 84 to 87	180° Two-Piece Long } Al Anodized	—	—	—	—	—
		—	—	—	—	—
	180° Two-Piece Short } Al Anodized	—	—	—	—	—
		—	—	—	—	—
	90° Two-Piece Long } Nickel Plated Steel	—	—	—	—	—
		—	—	—	—	—
		—	—	—	—	—
		—	—	—	—	—
		—	201378-2	—	—	201384-2
		—	201360-2	201227-2	201169-2	201165-2
90° One-Piece Short } Nickel Plated Steel	—	201467-2	201460-2	201468-2	201469-2	
	—	200389-2	200389-2	200389-2	200389-2	
GUIDE HARDWARE Page 81	Center Male } Stainless Steel	—	200390-2	200390-2	200390-2	200390-2
		—	—	—	—	200833-2
		—	—	—	—	200835-2
		—	—	—	—	—
LOCKING SPRINGS ¹ Page 80	Male—Nickel Plated Spring Steel	—	201921-1	201921-1	201923-1	201925-1
	Female—Stainless Steel	—	201922-1	201922-1	—	201926-1
PIN HOODS Pages 82 and 83	Internal Open End } Nickel Plated Steel	—	201363-4	—	201785-4	201786-4
	Internal Closed End } Nickel Plated Steel	—	—	—	—	—
	External Closed End } Al Iridite	—	—	—	—	—
	External Closed End } Nickel Plated Steel	—	—	—	—	—

¹Each part number contains two locking springs. Order one male and one female for each mated pair of connectors.

Cable-to-Cable (Continued)

1. Confirm that **Application C** (at left) most closely meets your requirements. (Other applications are shown on pages 10-13 and 16 through 25.)
2. Find the appropriate column for the number of positions required.
3. Select part numbers required for the application listed in the column below the number of positions.

If a part number is not listed for a particular item, it is not available.

If more than one part number is listed for a particular hardware item, choose the one which best fits your application.
4. Dimensional information is available on the indicated pages under description column.
5. Select Contacts: Type II (page 30), Type III+ (pages 31 through 35) or Subminiature Coaxial (pages 40, 41).

Special application housings may be substituted for these standard housings. See Special Application Section.

This cable-to-cable application utilizes locking springs, one-piece shields, a pin hood for pin protection and guide hardware. The shields are available with both 180° and 90° cable exits. The 180° shields are available in a long version which provides pin protection in lieu of a pin hood.

A short shield and a pin hood or a long shield can be used on one side only of a mated pair of connectors. The mating connector must use a short shield.

The 34 and 50 position connectors can be used with either center or corner guide hardware. If center guides are used, an additional four 4-40 screws are required to secure the locking springs. If corner guides are used, an additional two 4-40 screws will be required to attach the shield. Corner guides require four guide pins and four guide sockets for each mated pair of connectors.

Number of Positions						Component Description		
41	50	75	104	104 CF	160 CF			
202135-2	201358-1	—	—	—	—	Plug Block	} Phenolic	STANDARD HOUSINGS Pages 44 to 51
201302-1	200277-2	—	—	—	—	Receptacle Block		
202135-4	201358-3	—	—	—	—	Plug Block	} Diallyl Phthalate	
201302-3	200277-4	—	—	—	—	Receptacle Block		
—	—	—	—	1-201692-6	—	Plug Block	} Polyester	
—	—	—	—	—	—	Receptacle Block		
—	—	—	—	—	—	180° Two-Piece Long	} Al Anodized Zinc Plated Steel	
—	—	—	—	—	—	180° Two-Piece Short		
—	—	—	—	—	—	180° Two-Piece Short	} Al Anodized Zinc Plated Steel Zinc Plated Cast Al	
—	—	—	—	—	—	90° Two-Piece Long		
—	—	—	—	—	—	90° Two-Piece Short	} Nickel Plated Steel	SHIELDS Pages 84 to 87
—	—	—	—	—	—	45° Two-Piece Short		
—	—	—	—	—	—	45° Two-Piece Deep		
—	—	—	—	—	—	180° One-Piece Long		
—	—	—	—	—	—	180° One-Piece Short		
—	—	—	—	—	—	90° One-Piece Short		
201486-2	201470-2	—	—	—	—	Center Male	} Stainless Steel	GUIDE HARDWARE Page 81
200389-2	200389-2	—	—	—	—	Center Female		
200390-2	200390-2	—	—	—	—	Corner Male		
—	200833-2	—	—	—	—	Corner Female		
—	200835-2	—	—	—	—	Corner Female		
201921-1	201925-1	—	—	—	—	Male—Nickel Plated Spring Steel		LOCKING SPRINGS¹ Page 80
201922-1	201926-1	—	—	—	—	Female—Stainless Steel		
—	—	—	—	—	—	Internal Open End	Nickel Plated Steel	PIN HOODS Pages 82 and 83
—	—	—	—	—	—	Internal Closed End	Nickel Plated Steel	
—	—	—	—	—	—	External Closed End	Al Iridite	
—	—	—	—	—	—	External Closed End	Nickel Plated Steel	

Dimensions are shown for reference purposes only.

Dimensions are in inches and millimeters unless otherwise specified. Values in brackets are metric equivalents.

Specifications subject to change.

Technical Support Center
1-800-522-6752
www.tycoelectronics.com

Cable-to-Cable (Continued)

Application

D

Featured Hardware

- Shields (Two-piece)
- Pin Hoods
- Jackscrews
- Strain Relief Clamps
- Guide Hardware

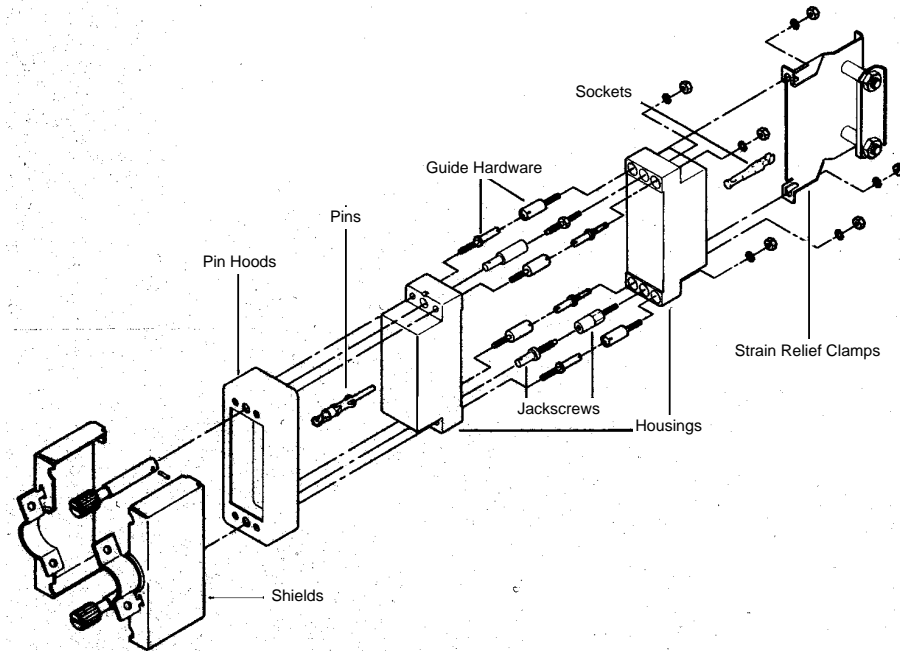

Component Description			Number of Positions				
			6	14	20	26	34
STANDARD HOUSINGS Pages 44 to 51	Plug Block Receptacle Block	Phenolic	—	—	201356-1	201359-1	1-201357-1
			—	—	200346-2	200512-2	200838-2
	Plug Block Receptacle Block	Diallyl Phthalate	—	—	201356-3	201359-3	201357-3
			—	—	200346-4	200512-3	200838-3
Plug Block Receptacle Block	Polyester	—	—	—	—	213800-1	
		—	—	—	—	213802-1	
SHIELDS Pages 84 to 87	180° Two-Piece Long	Al Anodized Nickel Plated Steel	—	—	—	201576-1	201571-1
			—	—	—	201576-2	201571-2
	180° Two-Piece Short	Al Anodized Nickel Plated Steel	—	—	—	—	200517-1
			—	—	204087-1	200514-2	200517-2
	90° Two-Piece Long 90° Two-Piece Short 45° Two-Piece Short 45° Two-Piece Deep 180° One-Piece Long 180° One-Piece Short 90° One-Piece Short	Nickel Plated Steel	—	—	—	—	—
			—	—	—	—	—
			—	—	—	—	—
			—	—	—	—	—
			—	—	—	—	—
			—	—	—	—	—
STRAIN RELIEF CLAMPS Page 88	Long Short	Nickel Plated Steel	—	—	—	201845-1	201846-1
			—	—	—	201229-1	—
	Long Short	Stainless Steel	—	—	—	—	—
			—	—	201237-1	—	201224-1
JACKSCREWS¹ Pages 78 and 79	Fixed Male Fixed Female	Stainless Steel	—	—	201092-1	201092-1	201092-1
			—	—	201089-1	201089-1	201089-1
	Long-Long Male Long-Long Female Long Male Long Female Short-Short Male Short-Short Female	Tip: Stainless Steel Body: Die Cast Zinc	—	—	—	—	—
			—	—	—	—	—
			—	—	201413-1	201413-1	201413-1
			—	—	201414-1	201414-1	201414-1
GUIDE HARDWARE Page 81	Center Male Center Female Corner Male Corner Female	Stainless Steel	—	—	—	—	—
			—	—	—	—	—
			—	—	—	—	200833-2
			—	—	—	—	200835-2
PIN HOODS Pages 82 and 83	Internal Open End Internal Closed End	Nickel Plated Steel	—	—	—	—	201786-4
			—	—	—	—	202434-4
	External Closed End External Closed End	Al Iridite Nickel Plated Steel	—	—	—	—	201350-2
			—	—	—	—	—

¹Listed Jackscrews have 6-32 single lead threads. For corresponding Jackscrews with 6-32 double lead threads, refer to pages 78 and 79.

Cable-to-Cable (Continued)

1. Confirm that **Application D** (at left) most closely meets your requirements. (Other applications are shown on pages 10-15 and 18 through 25.)
2. Find the appropriate column for the number of positions required.
3. Select part numbers required for the application listed in the column below the number of positions.

If a part number is not listed for a particular item, it is not available.

If more than one part number is listed for a particular hardware item, choose the one which best fits your application.
4. Dimensional information is available on the indicated pages under description column.
5. Select Contacts: Type II (page 30), Type III+ (pages 31 through 35) or Subminiature Coaxial (pages 40, 41).

Special application housings may be substituted for these standard housings. See Special Application Section.

This cable-to-cable application utilizes jackscrews, a two-piece short shield, a strain relief clamp, a pin hood for pin protection and guide hardware.

Do not use a pin hood in combination with the shield for sizes 20, 26 and 41. A long shield may be used in lieu of pin hood for pin protection for all sizes except the 20 position. Shields are available with 180° cable exit and for the 50 through 104 position connectors, a 90° cable exit.

Select the appropriate jackscrew length for the type of shield chosen as indicated by symbol (△▲).

Number of Positions						Component Description			
41	50	75	104	104 CF	160 CF				
202135-2	201358-1	201310-1	201345-1	—	—	Plug Block Receptacle Block	} Phenolic	STANDARD HOUSINGS Pages 44 to 51	
201302-1	200277-2	201311-1	201037-1	—	—	Plug Block Receptacle Block			
202135-4	201358-3	201310-3	201345-2	—	—	Plug Block Receptacle Block	} Diallyl Phthalate		
201302-3	200277-4	201311-3	—	—	—	Plug Block Receptacle Block			
—	—	—	—	1-201692-6	—	Plug Block Receptacle Block	} Polyester		
—	—	—	—	—	—	—			
—	201443-1△	—	—	—	—	180° Two- Piece Long	} Al Anodized Nickel Plated Steel		
202383-2	201443-2△	202713-2▲	204173-2▲	—	—	—			
—	200532-1△	—	—	—	—	—	} Al Anodized Nickel Plated Steel Nickel Plated Cast Al		
202383-1	200532-2△	202713-1▲	204173-1▲	—	—	180° Two- Piece Short			
—	—	—	201131-1△	—	—	—	} Nickel Plated Steel	SHIELDS Pages 84 to 87	
—	203975-2▲	202711-3▲	—	—	—	90° Two-Piece Long			
—	203975-1▲	202711-1▲	—	—	—	90° Two-Piece Short			
—	—	—	—	—	—	45° Two-Piece Short			
—	—	—	—	—	—	45° Two-Piece Deep			
—	—	—	—	—	—	180° One-Piece Long			
—	—	—	—	—	—	180° One-Piece Short			
—	—	—	—	—	—	90° One-Piece Short			
—	—	—	201849-1	—	—	Long Short	} Nickel Plated Steel	STRAIN RELIEF CLAMPS Page 88	
—	201182-1	200730-1	—	—	—	—			
201766-1	201847-1	201848-1	—	—	—	Long Short	} Stainless Steel		
—	—	—	—	—	—	—			
201092-1	201092-1	201092-1	201092-1	—	—	Fixed Male Fixed Female	} Stainless Steel	JACKSCREWS¹ Pages 78 and 79	
201089-1	201089-1	201089-1	201089-1	—	—	—			
—	207234-1▲	207234-1▲	207234-1▲	—	—	Long-Long Male Long-Long Female	} Tip: Stainless Steel Body: Die Cast Zinc		
—	207235-1▲	207235-1▲	207235-1▲	—	—	Long Male			
201413-1	201413-1△	201413-1△	201413-1△	—	—	Long Female			
201414-1	201414-1△	201414-1△	201414-1△	—	—	Short-Short Male Short-Short Female			
—	—	—	—	—	—	Center Male Center Female	} Stainless Steel		GUIDE HARDWARE Page 81
—	200833-2	201046-2	201046-2	—	—	Corner Male Corner Female			
—	200835-2	201047-2	201047-2	—	—	—	} Nickel Plated Steel		
—	—	—	—	—	—	Internal Open End			
—	202394-2	201369-4	201364-4	—	—	Internal Closed End	} Nickel Plated Steel	PIN HOODS Pages 82 and 83	
—	—	—	—	—	—	External Closed End			
—	—	—	—	—	—	External Closed End	} Al Iridite		
—	201390-5	201368-4	201346-4	—	—	External Closed End		} Nickel Plated Steel	

Dimensions are shown for reference purposes only.

Dimensions are in inches and millimeters unless otherwise specified. Values in brackets are metric equivalents.

Specifications subject to change.

Technical Support Center
1-800-522-6752
www.tycoelectronics.com

Cable-to-Panel

Application

E

Featured Hardware

- Strain Relief Clamps
- Locking Springs
- Pin Hoods
- Guide Hardware

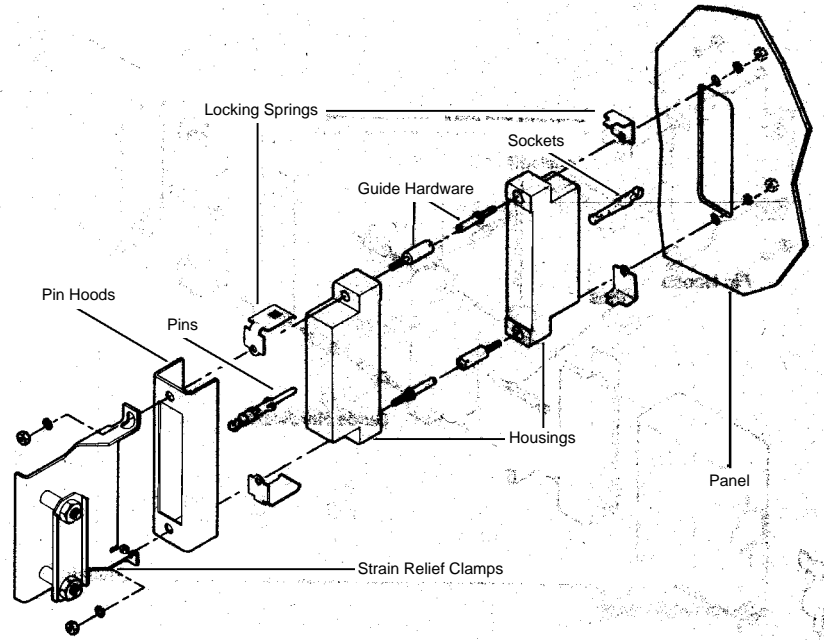

Component Description		Number of Positions				
		6	14	20	26	34
STANDARD HOUSINGS Pages 44 to 51	Plug Block Receptacle Block } Phenolic	202758-1	201355-1	201356-1	201359-1	1-201357-1
		202757-1	201298-1	200346-2	200512-2	200838-2
	Plug Block Receptacle Block } Diallyl Phthalate	202758-3	—	201356-3	201359-3	201357-3
		202757-3	201298-3	200346-4	200512-3	200838-3
Plug Block Receptacle Block } Polyester	—	—	—	—	213800-1	
	—	—	—	—	213802-1	
STRAIN RELIEF CLAMPS Page 88	Long Short } Nickel Plated Steel	—	201843-1	—	201845-1	201846-1
		203432-1	200686-1	—	201229-1	—
	Long Short } Stainless Steel	—	—	—	—	—
		—	—	201237-1	—	201224-1
GUIDE HARDWARE Page 81	Center Male } Stainless Steel	200389-2	200389-2	200389-2	200389-2	200389-2
	Center Female } Stainless Steel	200390-2	200390-2	200390-2	200390-2	200390-2
	Corner Male } Stainless Steel	—	—	—	—	200833-2
	Corner Female } Stainless Steel	—	—	—	—	200835-2
LOCKING SPRINGS ¹ Page 80	Male—Nickel Plated Spring Steel	201921-1	201921-1	201921-1	201923-1	201925-1
	Female—Stainless Steel	201922-1	201922-1	201922-1	—	201926-1
PIN HOODS Pages 82 and 83	Internal Open End } Nickel Plated Steel	204258-6	201363-4	—	201785-4	201786-4
	Internal Closed End } Nickel Plated Steel	—	—	—	—	—
	External Closed End } Al Iridite	—	—	—	—	—
	External Closed End } Nickel Plated Steel	—	—	—	—	—

¹Each part number contains two locking springs. Order one male and one female for each mated pair of connectors.

Cable-to-Panel (Continued)

1. Confirm that **Application E** (at left) most closely meets your requirements. (Other applications are shown on pages 10-17 and 20 through 25.)
2. Find the appropriate column for the number of positions required.
3. Select part numbers required for the application listed in the column below the number of positions.

If a part number is not listed for a particular item, it is not available.

If more than one part number is listed for a particular hardware item, choose the one which best fits your application.
4. Dimensional information is available on the indicated pages under description column.
5. Select Contacts: Type II (page 30), Type III+ (pages 31 through 35) or Subminiature Coaxial (pages 40, 41).

Special application housings and posted housings may be substituted for these standard housings. See Special Application and Posted Connectors Sections.

This cable-to-panel application utilizes locking springs, strain relief clamps, a pin hood for pin protection and guide hardware.

The 34 and 50 position connectors can be used with either center or corner guide hardware. If center guide hardware is used, an additional four 4-40 screws, nuts and lockwashers are required to secure the locking springs. Corner guides require four guide pins and four guide sockets for each mated pair of connectors.

Number of Positions						Component Description			
41	50	75	104	104 CF	160 CF				
202135-2	201358-1	—	—	—	—	Plug Block Receptacle Block	Phenolic	STANDARD HOUSINGS Pages 44 to 51	
201302-1	200277-2	—	—	—	—				
202135-4	201358-3	—	—	—	—	Plug Block Receptacle Block	Diallyl Phthalate		
201302-3	200277-4	—	—	—	—				
—	—	—	—	1-201692-6	—	Plug Block Receptacle Block	Polyester		
—	—	—	—	—	—				
—	—	—	—	—	—	Long Short	Nickel Plated Steel		
—	201182-1	—	—	—	—				
201766-1	201847-1	—	—	—	—	Long Short	Stainless Steel		STRAIN RELIEF CLAMPS Page 88
—	—	—	—	—	—				
200389-2	200389-2	—	—	—	—	Center Male Center Female Corner Male Corner Female	Stainless Steel	GUIDE HARDWARE Page 81	
200390-2	200390-2	—	—	—	—				
—	200833-2	—	—	—	—				
—	200835-2	—	—	—	—				
201921-1	201925-1	—	—	—	—	Male—Nickel Plated Spring Steel		LOCKING SPRINGS¹ Page 80	
201922-1	201926-1	—	—	—	—	Female—Stainless Steel			
—	—	—	—	—	—	Internal Open End	Nickel Plated Steel	PIN HOODS Pages 82 and 83	
—	—	—	—	—	—	Internal Closed End	Nickel Plated Steel		
—	—	—	—	—	—	External Closed End	Al Iridite		
—	—	—	—	—	—	External Closed End	Nickel Plated Steel		

Dimensions are shown for reference purposes only.

Dimensions are in inches and millimeters unless otherwise specified. Values in brackets are metric equivalents.

Specifications subject to change.

Technical Support Center
1-800-522-6752
www.tycoelectronics.com

Cable-to-Panel (Continued)

Application

F

Featured Hardware

- Strain Relief Clamps
- Pin Hoods
- Jackscrews
- Guide Hardware

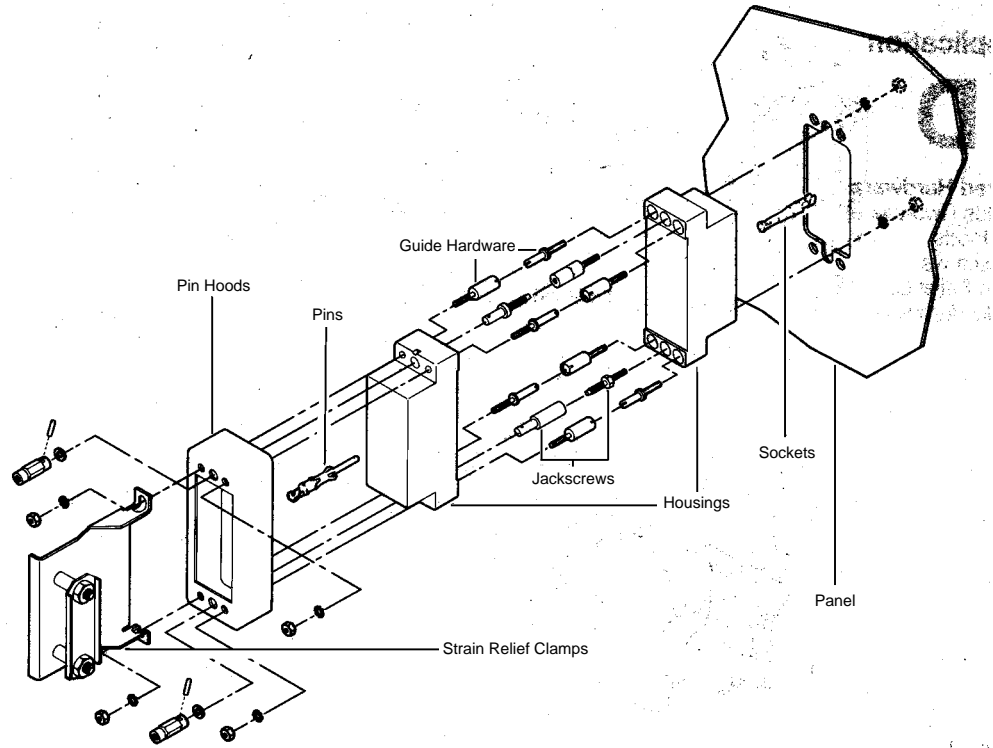

Connector/Hardware Selection Guide

Component Description		Number of Positions					
		6	14	20	26	34	
STANDARD HOUSINGS Pages 44 to 51	Plug Block Receptacle Block	Phenolic	202758-1	201355-1	201356-1	201359-1	1-201357-1
			202757-1	201298-1	200346-2	200512-2	200838-2
	Plug Block Receptacle Block	Diallyl Phthalate	202758-3	—	201356-3	201359-3	201357-3
			202757-3	201298-3	200346-4	200512-3	200838-3
	Plug Block Receptacle Block	Polyester	—	—	—	—	213800-1
			—	—	—	—	213802-1
STRAIN RELIEF CLAMPS Page 88	Long Short	Nickel Plated Steel	—	201843-1	—	201845-1	201846-1
			203432-1	200686-1	—	201229-1	—
	Long Short	Stainless Steel	—	—	—	—	—
			—	—	201237-1	—	201224-1
JACKSCREWS¹ Pages 78 and 79	Fixed Male Fixed Female	Stainless Steel	201092-1	201092-1	201092-1	201092-1	201092-1
			201089-1	201089-1	201089-1	201089-1	201089-1
	Long-Long Male Long-Long Female	Tip: Stainless Steel	—	—	—	—	—
			—	—	—	—	—
	Long Male Long Female	Body: Die Cast Zinc	—	—	—	—	—
			201827-1	201827-1	201827-1	201827-1	201827-1
	Short-Short Male Short-Short Female		201828-1	201828-1	201828-1	201828-1	201828-1
			—	—	—	—	—
GUIDE HARDWARE Page 81	Center Male Center Female	Stainless Steel	—	—	—	—	—
			—	—	—	—	—
	Corner Male Corner Female		—	—	—	—	200833-2
			—	—	—	—	200835-2
PIN HOODS Pages 82 and 83	Internal Open End	Nickel Plated Steel	204258-6	201363-4	—	201785-4	201786-4
	Internal Closed End	Nickel Plated Steel	—	—	—	—	202434-4
	External Closed End	Al Iridite	—	—	—	201349-2	201350-2
	External Closed End	Nickel Plated Steel	—	—	—	—	—

¹Listed Jackscrews have 6-32 single lead threads. For corresponding Jackscrews with 6-32 double lead threads, refer to pages 78 and 79.

Cable-to-Panel (Continued)

1. Confirm that **Application F** (at left) most closely meets your requirements. (Other applications are shown on pages 10-19 and 22 through 25.)
2. Find the appropriate column for the number of positions required.
3. Select part numbers required for the application listed in the column below the number of positions.

If a part number is not listed for a particular item, it is not available.

If more than one part number is listed for a particular hardware item, choose the one which best fits your application.
4. Dimensional information is available on the indicated pages under description column.
5. Select Contacts: Type II (page 30), Type III+ (pages 31 through 35) or Subminiature Coaxial (pages 40, 41).

Special application housings and posted housings may be substituted for these standard housings. See Special Application and Posted Connectors Sections.

This cable-to-panel application utilizes jackscrews, strain relief clamps and guide hardware. A pin hood is provided for pin protection. Sizes 6, 14, 20, 26, and 41 **do not** use guide hardware for this application.

Number of Positions						Component Description		
41	50	75	104	104 CF	160 CF			
202135-2	201358-1	201310-1	201345-1	—	—	Plug Block Receptacle Block	Phenolic	STANDARD HOUSINGS Pages 44 to 51
201302-1	200277-2	201311-1	201037-1	—	—			
202135-4	201358-3	201310-3	201345-2	—	—	Plug Block Receptacle Block	Diallyl Phthalate	
201302-3	200277-4	201311-3	—	—	—			
—	—	—	—	1-201692-6	—	Plug Block Receptacle Block	Polyester	
—	—	—	—	—	—			
—	—	—	201849-1	—	—	Long Short	Nickel Plated Steel	STRAIN RELIEF CLAMPS Page 88
—	201182-1	200730-1	—	—	—			
201766-1	201847-1	201848-1	—	—	—	Long Short	Stainless Steel	
—	—	—	—	—	—			
201092-1	201092-1	201092-1	201092-1	—	—	Fixed Male Fixed Female	Stainless Steel	
201089-1	201089-1	201089-1	201089-1	—	—			
—	—	—	—	—	—	Long-Long Male Long-Long Female Long Male Long Female Short-Short Male Short-Short Female	Tip: Stainless Steel Body: Die Cast Zinc	JACKSCREWS¹ Pages 78 and 79
—	—	—	—	—	—			
—	—	—	—	—	—			
201827-1	201827-1	201827-1	201827-1	—	—			
201828-1	201828-1	201828-1	201828-1	—	—			
—	—	—	—	—	—	Center Male Center Female Corner Male Corner Female	Stainless Steel	GUIDE HARDWARE Page 81
—	200833-2	201046-2	201046-2	—	—			
—	200835-2	201047-2	201047-2	—	—			
—	—	—	—	—	—			
—	—	—	—	—	—	Internal Open End	Nickel Plated Steel	
—	202394-2	201369-4	201364-4	—	—	Internal Closed End	Nickel Plated Steel	PIN HOODS Pages 82 and 83
—	—	—	—	—	—	External Closed End	Al Iridite	
—	201390-5	201368-4	201346-4	—	—	External Closed End	Nickel Plated Steel	

Cable-to-Panel (Continued)

Application

G

Featured Hardware

- Shields (One-piece)
- Pin Hoods
- Locking Springs
- Guide Hardware

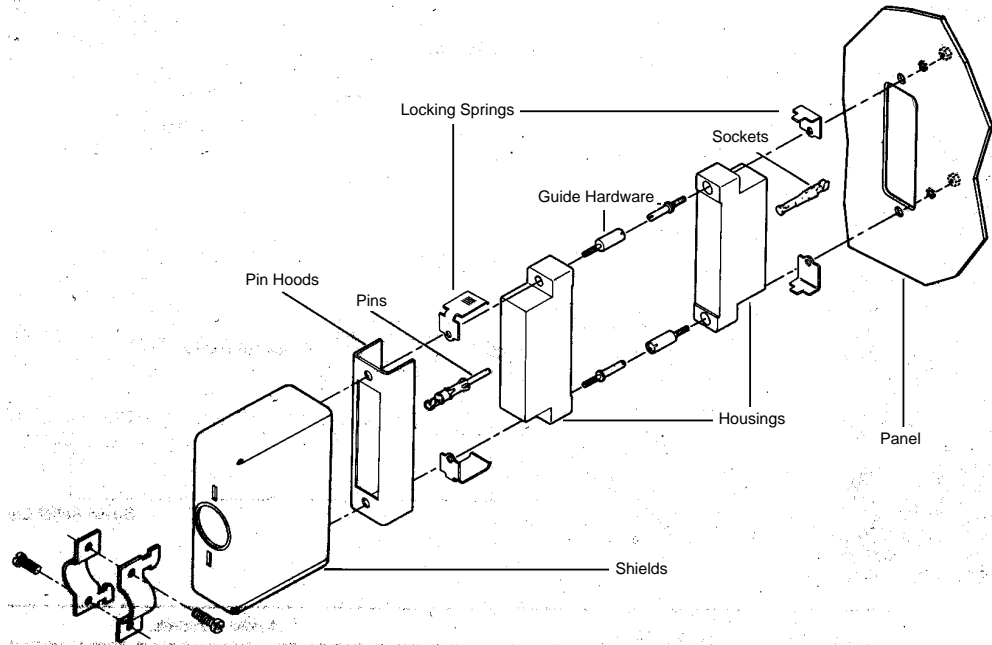

Connector/Hardware Selection Guide

Component Description	Number of Positions						
	6	14	20	26	34		
STANDARD HOUSINGS Pages 44 to 51	Plug Block Receptacle Block } Phenolic	—	201355-1	201356-1	201359-1	1-201357-1	
		—	201298-1	200346-2	200512-2	200838-2	
	Plug Block Receptacle Block } Diallyl Phthalate	—	—	201356-3	201359-3	201357-3	
		—	201298-3	200346-4	200512-3	200838-3	
	Plug Block Receptacle Block } Polyester	—	—	—	—	213800-1	
		—	—	—	—	213802-1	
SHIELDS Pages 84 to 87	180° Two-Piece Long { Al Anodized Nickel Plated Steel	—	—	—	—	—	
		—	—	—	—	—	
	180° Two-Piece Short { Al Anodized Nickel Plated Steel Nickel Plated Cast Al	—	—	—	—	—	
		—	—	—	—	—	
		—	—	—	—	—	
	90° Two-Piece Long } 90° Two-Piece Short } 45° Two-Piece Short } 45° Two-Piece Deep } 180° One-Piece Long } 180° One-Piece Short } 90° One-Piece Short }	Nickel Plated Steel	—	—	—	—	—
			—	—	—	—	—
			—	—	—	—	—
			—	201378-2	—	—	201384-2
			—	201360-2	201227-2	201169-2	201165-2
GUIDE HARDWARE Page 81	Stainless Steel	Center Male	—	200389-2	200389-2	200389-2	
		Center Female	—	200390-2	200390-2	200390-2	
		Corner Male	—	—	—	200833-2	
		Corner Female	—	—	—	200835-2	
		—	—	—	—	—	
LOCKING SPRINGS ¹ Page 80	Male—Nickel Plated Spring Steel	—	201921-1	201921-1	201923-1	201925-1	
	Female—Stainless Steel	—	201922-1	201922-1	—	201926-1	
PIN HOODS Pages 82 and 83	Internal Open End	Nickel Plated Steel	—	201363-4	—	201785-4	
	Internal Closed End	Nickel Plated Steel	—	—	—	—	
	External Closed End	Al Iridite	—	—	—	—	
	External Closed End	Nickel Plated Steel	—	—	—	—	

¹Each part number contains two locking springs. Order one male and one female for each mated pair of connectors.

Cable-to-Panel (Continued)

1. Confirm that **Application G** (at left) most closely meets your requirements. (Other applications are shown on pages 10-21 and 24, 25.)
2. Find the appropriate column for the number of positions required.
3. Select part numbers required for the application listed in the column below the number of positions.

If a part number is not listed for a particular item, it is not available.

If more than one part number is listed for a particular hardware item, choose the one which best fits your application.
4. Dimensional information is available on the indicated pages under description column.
5. Select Contacts: Type II (page 30), Type III+ (pages 31 through 35) or Subminiature Coaxial (pages 40, 41).

Special application housings and posted housings may be substituted for these standard housings. See Special Application and Posted Connectors Sections.

This cable-to-panel application utilizes locking springs, one-piece shields, a pin hood for pin protection and guide hardware. The shields are available with both 180° and 90° cable exits. The 180° shields are available in a long version which provides pin protection in lieu of a pin hood.

Do not select a long shield and a pin hood.

The 34 and 50 position connectors can be used with either center or corner guide hardware. If center guides are used, an additional four 4-40 screws are required to secure the locking springs. If corner guides are used, an additional two 4-40 screws will be required to attach the shield. Corner guides require four guide pins and four guide sockets for each mated pair.

Number of Positions						Component Description		
41	50	75	104	104 CF	160 CF			
202135-2	201358-1	—	—	—	—	Plug Block Receptacle Block	Phenolic	STANDARD HOUSINGS Pages 44 to 51
201302-1	200277-2	—	—	—	—			
202135-4	201358-3	—	—	—	—	Plug Block Receptacle Block	Diallyl Phthalate	
201302-3	200277-4	—	—	—	—			
—	—	—	—	1-201692-6	—	Plug Block Receptacle Block	Polyester	
—	—	—	—	—	—			
—	—	—	—	—	—	180° Two- Piece Long	Al Anodized Nickel Plated Steel	
—	—	—	—	—	—			
—	—	—	—	—	—	180° Two- Piece Short	Al Anodized Nickel Plated Steel Nickel Plated Cast Al	
—	—	—	—	—	—			
—	—	—	—	—	—	90° Two-Piece Long 90° Two-Piece Short 45° Two-Piece Short 45° Two-Piece Deep 180° One-Piece Long 180° One-Piece Short 90° One-Piece Short	Nickel Plated Steel	SHIELDS Pages 84 to 87
—	—	—	—	—	—			
—	—	—	—	—	—			
—	—	—	—	—	—			
—	—	—	—	—	—			
200389-2	200389-2	—	—	—	—	Center Male Center Female Corner Male Corner Female	Stainless Steel	GUIDE HARDWARE Page 81
200390-2	200390-2	—	—	—	—			
—	200833-2	—	—	—	—			
—	200835-2	—	—	—	—			
201921-1	201925-1	—	—	—	—	Male—Nickel Plated Spring Steel	Female—Stainless Steel	LOCKING SPRINGS¹ Page 80
201922-1	201926-1	—	—	—	—			
—	—	—	—	—	—	Internal Open End	Nickel Plated Steel	PIN HOODS Pages 82 and 83
—	—	—	—	—	—	Internal Closed End	Nickel Plated Steel	
—	—	—	—	—	—	External Closed End	Al Iridite	
—	—	—	—	—	—	External Closed End	Nickel Plated Steel	

Dimensions are shown for reference purposes only.

Dimensions are in inches and millimeters unless otherwise specified. Values in brackets are metric equivalents.

Specifications subject to change.

Technical Support Center
1-800-522-6752
www.tycoelectronics.com

Cable-to-Panel (Continued)

Application
H

Featured Hardware

- Shields (Two-piece)
- Pin Hoods
- Guide Hardware
- Jackscrews

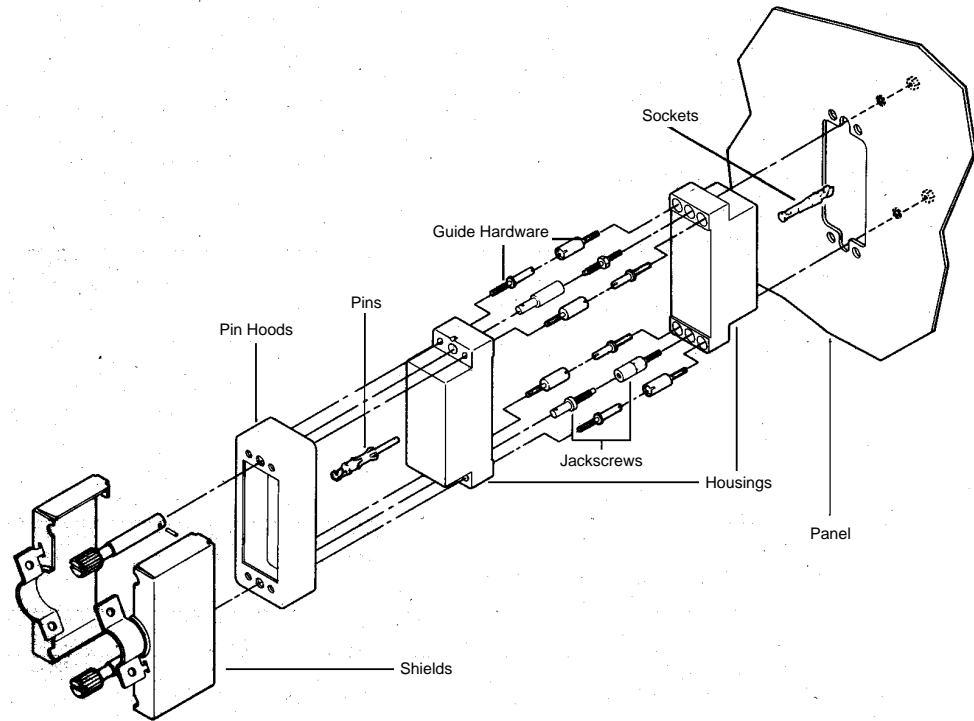

Component Description		Number of Positions					
		6	14	20	26	34	
STANDARD HOUSINGS Pages 44 to 51	Plug Block Receptacle Block	Phenolic	—	—	201356-1	201359-1	1-201357-1
			—	—	200346-2	200512-2	200838-2
	Plug Block Receptacle Block	Diallyl Phthalate	—	—	201356-3	201359-3	201357-3
			—	—	200346-4	200512-3	200838-3
Plug Block Receptacle Block	Polyester		—	—	—	213800-1	
			—	—	—	213802-1	
SHIELDS Pages 84 to 87	180° Two-Piece Long	Al Anodized	—	—	—	201576-1	201571-1
		Nickel Plated Steel	—	—	—	201576-2	201571-2
	180° Two-Piece Short	Al Anodized	—	—	—	—	200517-1
		Nickel Plated Steel	—	—	204087-1	200514-2	200517-2
	90° Two-Piece Long 90° Two-Piece Short 45° Two-Piece Short 45° Two-Piece Deep 180° One-Piece Long 180° One-Piece Short 90° One-Piece Short	Nickel Plated Steel		—	—	—	—
				—	—	—	—
				—	—	—	—
				—	—	—	—
			—	—	—	—	
JACKSCREWS¹ Pages 78 and 79	Fixed Male Fixed Female	Stainless Steel	—	—	201092-1	201092-1	201092-1
			—	—	201089-1	201089-1	201089-1
	Long-Long Male Long-Long Female	Tip: Stainless Steel		—	—	—	—
				—	—	201413-1	201413-1
	Long Male Long Female	Body: Die Cast Zinc		—	—	—	—
				—	—	201414-1	201414-1
	Short-Short Male Short-Short Female		—	—	—	—	—
		—	—	—	—	—	
GUIDE HARDWARE Page 81	Center Male Center Female Corner Male Corner Female	Stainless Steel	—	—	—	—	—
			—	—	—	—	—
			—	—	—	—	200833-2
			—	—	—	—	200835-2
PIN HOODS Pages 82 and 83	Internal Open End Internal Closed End External Closed End External Closed End	Nickel Plated Steel	—	—	—	—	201786-4
		Nickel Plated Steel	—	—	—	—	202434-4
		Al Iridite	—	—	—	—	201350-2
		Nickel Plated Steel	—	—	—	—	—

¹Listed Jackscrews have 6-32 single lead threads. For corresponding Jackscrews with 6-32 double lead threads, refer to pages 78 and 79.

Cable-to-Panel (Continued)

1. Confirm that **Application H** (at left) most closely meets your requirements. (Other applications are shown on pages 10 through 23.)
2. Find the appropriate column for the number of positions required.
3. Select part numbers required for the application listed in the column below the number of positions.

If a part number is not listed for a particular item, it is not available.

If more than one part number is listed for a particular hardware item, choose the one which best fits your application.
4. Dimensional information is available on the indicated pages under description column.
5. Select Contacts: Type II (page 30), Type III+ (pages 31 through 35) or Subminiature Coaxial (pages 40, 41).

Special application housings and posted housings may be substituted for these standard housings. See Special Application and Posted Connectors Sections.

This cable-to-panel application utilizes jackscrews, a two-piece short shield, a strain relief clamp, a pin hood for pin protection and guide hardware.

Do not use a pin hood in combination with the shield for sizes 20, 26 and 41. A long shield may be used in lieu of pin hood for pin protection for all sizes except the 20 position. Shields are available with 180° cable exit and for the 50 thru 104 position connectors, a 90° cable exit. 104 CF has 90° and 45° cable exits. 160 CF has 45° cable exit.

Select the appropriate jackscrew length for the type of shield chosen as indicated by symbol (△▲).

Number of Positions						Component Description	
41	50	75	104	104 CF	160 CF		
202135-2	201358-1	201310-1	201345-1	201692-4	202799-2	Plug Block Receptacle Block	Phenolic
201302-1	200277-2	201311-1	201037-1	201532-4	202800-2	Plug Block Receptacle Block	
202135-4	201358-3	201310-3	201345-2	201692-3	202799-1	Plug Block Receptacle Block	Diallyl Phthalate
201302-3	200277-4	201311-3	—	201532-2	202800-1	Plug Block Receptacle Block	
—	—	—	—	1-201692-6	—	Plug Block Receptacle Block	Polyester
—	201443-1△	—	—	—	—	180° Two-Piece Long	Al Anodized Nickel Plated Steel
202383-2	201443-2△	202713-2▲	204173-2▲	—	—	180° Two-Piece Short	
—	200532-1△	—	—	—	—	180° Two-Piece Long	Al Anodized Nickel Plated Steel Nickel Plated Cast Al
202383-1	200532-2△	202713-1▲	204173-1▲	—	—	180° Two-Piece Short	
—	—	—	201131-1△	—	—	90° Two-Piece Long	Nickel Plated Steel
—	203975-2▲	202711-3▲	—	—	—	90° Two-Piece Short	
—	203975-1▲	202711-1▲	—	202395-1	—	45° Two-Piece Short	
—	—	—	—	202110-1	202798-1	45° Two-Piece Deep	
—	—	—	—	202169-1	—	180° One-Piece Long	
—	—	—	—	—	—	180° One-Piece Short	
—	—	—	—	—	—	90° One-Piece Short	
201092-1	201092-1	201092-1	201092-1	—	—	Fixed Male	Stainless Steel
201089-1	201089-1	201089-1	201089-1	—	—	Fixed Female	
—	207234-1▲	207234-1▲	207234-1▲	—	—	Long-Long Male	Tip: Stainless Steel Body: Die Cast Zinc
—	207235-1▲	207235-1▲	207235-1▲	—	—	Long-Long Female	
201413-1	201413-1△	201413-1△	201413-1△	—	—	Long Male	
201414-1	201414-1△	201414-1△	201414-1△	—	—	Long Female	
—	—	—	—	—	—	Short-Short Male	
—	—	—	—	—	—	Short-Short Female	
—	—	—	—	—	—	Center Male	Stainless Steel
—	—	—	—	—	—	Center Female	
—	200833-2	201046-2	201046-2	202173-5	201046-2	Corner Male	
—	200835-2	201047-2	201047-2	202174-1	201047-2	Corner Female	
—	—	—	—	—	—	Internal Open End	Nickel Plated Steel
—	202394-2	201369-4	201364-4	—	203743-4	Internal Closed End	Nickel Plated Steel
—	—	—	—	—	—	External Closed End	Al Iridite
—	201390-5	201368-4	201346-4	202119-2	203744-4	External Closed End	Nickel Plated Steel

STANDARD HOUSINGS
Pages 44 to 51

SHIELDS
Pages 84 to 87

JACKSCREWS¹
Pages 78 and 79

GUIDE HARDWARE
Page 81

PIN HOODS
Pages 82 and 83

Dimensions are shown for reference purposes only.

Dimensions are in inches and millimeters unless otherwise specified. Values in brackets are metric equivalents.

Specifications subject to change.

Technical Support Center
1-800-522-6752
www.tycoelectronics.com

Signal Contacts

Type III+, Crimp, Snap-In, Size 16

Precision formed pin and socket contacts in Size 16. They are used in M Series, Special M Series, "G" Series, Metrimate, Metrimate Drawer, and CPC Series 1 and 4 connectors. Contacts feature a high normal force which provides a low resistance in significant applications such as dry circuit signal conditions. Mating entry is closed-ended to prevent damage from stubbing due to misalignment. Stainless steel spring provides superior normal force and retention in the housing. AMP proprietary gold plating process is designed so that specified plating thicknesses are controlled on the inside of the socket, which is the critical contact mating area. The contacts are formed from brass. Single contact rating is 13 amperes at 30°C T-Rise.

See page 31 for product details.

Type III+, Solder Type, Size 16

As with the crimp snap-in Type III+, these precision formed solder-type contacts are also used in M Series, Special M Series, Metrimate, Metrimate Drawer, and CPC Series 1 and 4 connectors. Contacts feature a high normal force which provides a low resistance in significant applications, such as dry circuit conditions. A preformed wire barrel accepts both stranded and solid wire, while the preformed insulation barrel provides strain relief for various wire insulation thicknesses. Mating entry is closed-ended to prevent damage from stubbing due to misalignment. A stainless steel spring provides superior normal force and retention in the housing. AMP proprietary gold plating process is designed so that specified plating thicknesses are controlled on the inside of the socket, which is the critical contact area. Single contact current rating is 13 amperes at 30°C Temperature Rise.

See pages 34 and 35 for product details.

Type III+, Solder Tab, Size 16

A companion contact style to the crimp snap-in and solder-type, the Type III+ Solder Tab is compatible with the same AMP connector families, and features high normal forces to provide a low resistance in significant applications. A pre-crimped solder tab with slot accepts various sizes of solid and stranded wire. Mating entry is closed-ended to prevent stubbing due to misalignment. A stainless steel spring provides superior normal force and retention in the housing. AMP proprietary gold plating process is designed so that specified plating thicknesses are controlled on the inside of the socket, which is the critical contact area. Single contact current rating is 13 amperes at 30°C Temperature Rise.

See page 35 for product details.

Signal Contacts (Continued)

Type III+, Posted Version, Size 16

The last member of the Type III+ family of contacts, the posted version is compatible with M Series, Special M Series, Metrimate, Metrimate Drawer, and CPC Series 1 connectors. Precision formed, they are pre-crimped to various post configurations including those that accept TERMI-POINT Clip or wire-wrap type terminations. Contacts feature high normal force which provides a low resistance in significant applications. Mating entry is closed-ended to prevent damage from stubbing due to misalignment. A stainless steel spring provides superior normal force and retention in the housing. AMP proprietary gold plating process is designed so that specified plating thicknesses are controlled on the inside of the socket, which is the critical contact mating area. Contacts are formed from brass. Single contact current rating is 13 amperes at 30°C Temperature Rise.

See page 32 for product details.

Type II, Crimp, Snap-In, Size 16

Precision screw-machined pin and socket contacts, they are used in M Series, Special M Series, "G" Series, Metrimate, Metrimate Drawer, and CPC Series 1 and 4 connectors. Contacts feature high normal force which provides a low resistance in significant applications such as dry circuit signal conditions. Mating entry is closed-ended to prevent damage from stubbing due to misalignment. A stainless steel spring provides superior normal force and retention in the housing. The contact bodies are machined from solid brass. Single contact current rating is 13 amperes at 30°C Temperature Rise.

See page 30 for product details.

Power Contacts

Type I, Crimp, Snap-In, Size 12

Precision screw-machined pin and socket, Size 12 contacts, they are used in Special M Series and "G" Series connectors, and are inserted into the same cavities as Miniature Coaxial contacts. These contacts feature a high normal force which provides a low resistance in significant applications. Mating entry is closed-ended to prevent damage from stubbing due to misalignment. Beryllium copper springs are used to provide contact normal force and are assisted by a stainless steel hood which provides anti-overstress assurance. Single contact current rating is 23 amperes at 30°C Temperature Rise.

See page 36 for product details.

Type XII, Crimp-Type

Precision formed male and female contacts used in CPC Series 3 and 4, Special M Series and "G" Series connectors, these contacts offer a low cost power option which provides additional applied cost savings when terminated with semiautomatic application equipment. The contact body is made from 100% copper, which provides for excellent conductivity. Spring characteristics are derived from a captive stainless steel spring which assists the dual cantilever spring members of the female contact. Single contact current rating is 35 amperes at 30°C Temperature Rise.

See page 38 for product details.

High Current Upgrades

Precision screw-machined pin and socket contacts have increased current capability. All upgraded contacts use the high amperage Louvertac contact band. The design of this contact allows for increased current in the same form factor. For example, Type II/Type III+ upgraded contacts increase the current from 13 amperes free air to 23 amperes free air at a 30°C Temperature Rise.

See pages 37 and 39 for product details.



Coaxial Contacts

Subminiature, Crimp, Snap-In, Size 16

Precision screw-machined pin and socket, Size 16 contacts, they are used in M Series, Special M Series, and CPC Series 1 and 4. They provide cost effective solutions in applications where mixtures of signal, power, and coaxial cable terminations are desired. The contact outer shell is made from brass, while the center pin conductor is beryllium copper, and the socket is brass. Both the pin and socket center conductor are gold plated for maximum corrosion resistance and minimum contact resistance. The retention spring is stainless steel, while the ferrule is tin-lead plated copper. Contact design offers application of coaxial cable, shielded conductors, and twisted pair wire with a voltage rating of up to 200 VRMS, and a current rating of 1.0 ampere at 30°C Temperature Rise.

See pages 40 and 41 for product details.

Miniature, Crimp, Snap-In, Size 12

Precision screw-machined, Size 12 pin and socket contacts, they are used in Special M Series and "G" Series connectors. They provide cost effective solutions in applications where a mixture of signal, power, and coaxial cable terminations is desirable. Contact body and center wire conductor are made from brass, and are gold plated for maximum corrosion resistance and minimum contact resistance. The retention spring is beryllium copper, and the ferrule is tin-lead plated copper. Contact design offers application of coaxial cable, shielded conductors, and twisted pair wire with a voltage rating of up to 325 VRMS, and a current rating of 7.5 amperes at 30°C Temperature Rise.

See pages 42 and 43 for product details.

Signal Contacts

Type II, Crimp, Snap-In

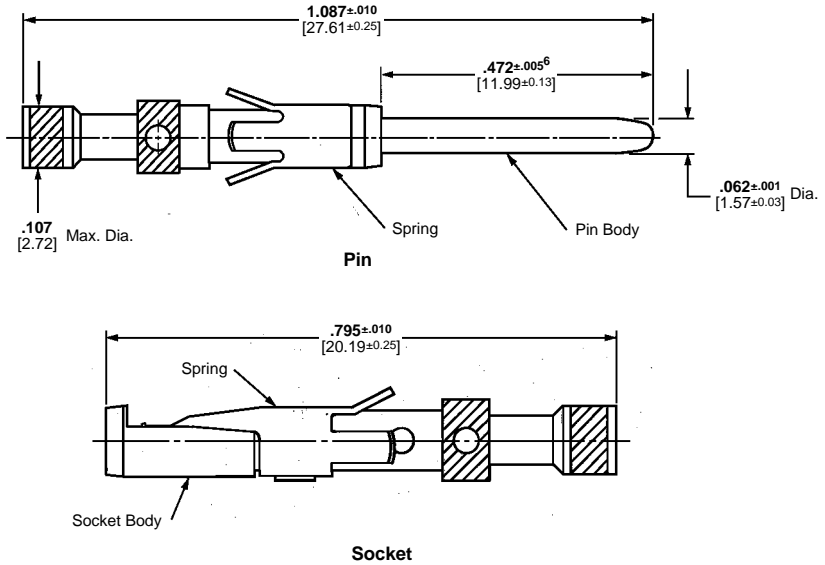

Material

Contact Body—Brass
Retention Spring—Stainless steel

Finish

Contact Body—.000030 [0.00076] gold over .000050 [0.00127] nickel. Gold thickness controlled on socket O.D.

Technical Documents

108-10039 Product Specification
114-10026 Application Specification

Contact Size 16—Pin Diameter .062 [1.57] (Test Current, 13 Ampere)‡

Wire Size Range AWG [mm ²]	Ins. Dia. Range ¹	Tape Mounted Contact No. ²		Loose Piece Contact No.		Contact Color Code	Tooling Part No.		
		Pin	Socket	Pin	Socket		Tape Mounted		Loose Piece
							Dies for AMP-TAPETRONIC Machine 69875		Dies for Pneumatic Tool*
28-24 0.08-0.20	.035-.055 0.89-1.40	201611-4	—	201611-14	201613-15	Red/Red	90249-2	90230-1	58305-1
	.048-.065 1.22-1.65	—	—	201334-14	201332-15	Red/Red			or 601967-1
24-20 0.2-0.6	.040-.062 1.02-1.57	201578-4	—	201578-14	201580-15	Yellow/Red	90249-2	90230-1	58305-1
	.055-.088 1.40-2.16	201330-6	201328-9	201330-14	201328-15	Yellow/Red			or 601967-1
18 (Two)	0.9-0.9 (Two)	No. Ins. Support	—	202725-14	202726-14	Blue	—	90231-2	45098 or 601967-1
18-16 0.8-1.4	.080-.105 2.03-2.67	—	—	202507-14	202508-15	—	—	—	90136-1 or 601967-1
	No. Ins. Support	200336-6	200333-8	200336-14	200333-14	Blue/Blue	90250-1	90231-2	45098 58541-1** or 601967-1
14 2	No. Ins. Support	212618-2 ³	201568-3	201570-14	201568-15	Violet/Blue	90250-1	90231-2	45098 58541-1** or 601967-1
		—	—	212618-13.6 [†]	—	—	—	—	—

¹Overall insulation crimp diameter, including crimp barrel, must not exceed .125 [3.18].
²For AMP-TAPETRONIC Machine No. 69875, order contacts by Tape Mounted Contact No., plus packaging code "IM REEL" (5000 parts per reel).
³Grounding pin is used to provide a make-first/break-last condition when mating and unmating connector halves.
⁴Use turret TH502 (1-601967-6) with hand tool 601967-1.
⁵Use turret TH501 (1-601967-5) with hand tool 601967-1.
⁶Pin length is .630±.005 [16.002±.127] on these two pins.
 *Use hand actuated Power Unit **Part No. 189721-2** or foot actuated Power Unit **Part No. 189722-2**. Both units require "C" Head Die Set Adapter **Part No. 318161-1** and an Adapter Holder **Part No. 356304-1** (with ratchet) or **Part No. 189928-1** (without ratchet). Request Catalog 124208 for more information on the 626 Pneumatic Tool System.

**Commercial PRO-CRIMPERII Hand Tool for field repair use only.

† Does not use Hand Tool 601967-1.

‡Single contact, free-air test current is not to be construed as contact rating current. Use only for testing. Refer to contact current carrying capability information on page 7.

Insertion Tool **Part No. 200893-2** (for insulation diameters .070 [1.78] or less).

Extraction Tool **Part No. 305183** (Instruction Sheet 408-1216)

Signal Contacts

Signal Contacts (Continued)

Type III+, Crimp, Snap-In

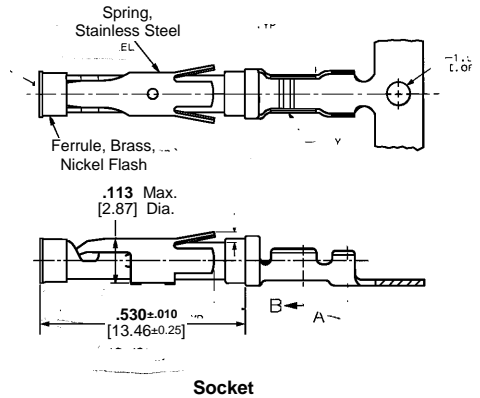
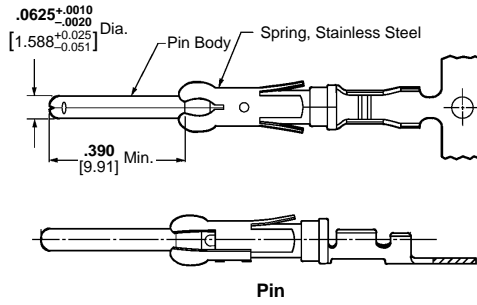
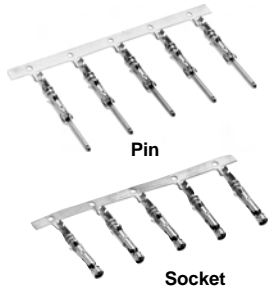

Material

Contact Body—Brass or phosphor bronze

Retention Spring—Stainless steel

Finish

See chart.

Related Product Data

Application Tooling—Pages 90, 91

Technical Documents

114-10004 Application Specification

108-10042 Product Specification

Contact Size 16—Pin Diameter .062 [1.57] (Test Current, 13 Ampere)‡

AWG	Wire Size Range mm ²	Ins. Dia. Range	Contact Finish	Strip Form Contact No.		Loose Piece Contact No.		Tooling Part No.	
				Pin	Socket	Pin	Socket	Loose Piece Hand Tool	Strip Form Applicators
30-28	0.05-0.09	.015-.030 0.38-0.76	Gold/Nickel ²	788085-3	788088-2	—	—	90716-1	567867-1*** or 567947-1*** or 680602-□***
			Sel. Gold/Nickel ³	788085-1	788088-1	788085-4	788088-3		
30-26	0.05-0.15	.040-.060 ¹ 1.02-1.52	Bright Tin-Lead	66425-6	66424-6	—	—	90066-7 ⁶	466598-□***
			Gold/Nickel ²	66425-7	66424-7	66429-3	66428-3		
			Sel. Gold/Nickel ³	66425-8	66424-8	66429-4	66428-4		
			Gold/Nickel ²	66393-7	66394-7	—	—		
26-24	0.12-0.2	.035-.055 ¹ 0.89-1.40	Sel. Gold/Nickel ³	66393-8	66394-8	66406-4	66405-4	90225-2 ⁶	466585-3***
			Bright Tin-Lead	66106-6	66108-6	66107-2	66109-2		
			Gold/Nickel ²	66106-7	66108-7	66107-3	66109-3		
			Sel. Gold/Nickel ³	66106-8	66108-8	66107-4	66109-4		
24-20	0.2-0.6	.080-.100 ¹ 2.03-2.54	Sel. Gold/Nickel ⁴	—	66108-1	—	66109-1	58495-1*	466908-2***
			Bright Tin-Lead	66102-7	66104-7	66103-2	66105-2		
			Gold/Nickel ²	66102-8	66104-8	66103-3	66105-3	90066-7 ⁶ or 58495-1*	466323-□*** or 466907-2***
			Sel. Gold/Nickel ³	66102-9	66104-9	66103-4	66105-4		
			—	2-66102-2	2-66104-3	1-66103-2	1-66105-3	90331-1 ⁶	466383-4*** or 466979-1*** or 567363-□***
			Sel. Gold/Nickel ⁴	—	66104-1	—	66105-1		
			Bright Tin-Lead	66564-6	66563-6	66566-2	66565-2	90067-5 ⁶ or 90225-2 ⁶	466324-□*** or 466942-1***
			Sel. Gold/Nickel ³	66564-8	66563-8	66566-4	66565-4		
Gold/Nickel ²	66332-5	66331-5	66400-1	66399-1					
Sel. Gold/Nickel ³	66332-7	66331-7	66400-3	66399-3					
18-16	0.8-1.4	.080-.100 ¹ 2.03-2.54	Sel. Gold/Nickel ³	66332-8	66331-8	66400-4	66399-4	90067-4 ⁶ or 90067-5 ⁶ or 58495-1*	466325-□*** or 466906-1***
			Sel. Gold/Nickel ⁴	—	66331-2	—	66399-2		
			Bright Tin-Lead	66098-2 ⁵ 66098-7	66100-7	66099-2	66101-2		
			Gold/Nickel ²	66098-8	66100-8	66099-3	66101-3		
18-14	0.8-2.0	.080-.100 ¹ 2.03-2.54	Sel. Gold/Nickel ³	66098-9	66100-9	66099-4	66101-4	90310-3 ⁶	466326-□*** or 466923-2***
			Sel. Gold/Nickel ⁴	66098-6	—	66099-1	—		
			Bright Tin-Lead	66359-6 1-66359-1	66358-6 1-66358-2 1-66358-4	66361-2 66361-7	66360-2 66360-7		
			Gold/Nickel ²	66359-9	66358-9	66361-3	66360-3		
			Sel. Gold/Nickel ³	1-66359-0	1-66358-0	66361-4	66360-4		
			Sel. Gold/Nickel ⁴	1-66359-2	1-66358-3	66361-8	66360-8		
.110-.150 ⁵ 2.79-3.81	—	—	Bright Tin-Lead	66597-1	66598-1	66602-1	66601-1	90310-2 ⁶	466958-1*** or 567364-□***
			Sel. Gold/Nickel ³	66597-2	66598-2	66602-2	66601-2		
			—	66358-1	—	66360-1			

¹Overall insulation crimp diameter, including crimp barrel, must not exceed .125 [3.18].
²0.00015 [0.00038] gold in the mating area over .000050 [0.00127] min. nickel.
³0.00030 [0.00076] gold in the mating area, with gold flash on remainder, over .000050 [0.00127] min. nickel.
⁴0.00030 [0.00076] gold in the mating area, with gold gradient on remainder, over .000050 [0.00127] min. nickel.
⁵Contacts can only be used in Metrimate, Series 1 (Arr. 23-24), Series 4 (Arr. 23-13M, 23-16M, 23-22M), and VDE connectors.

⁶To use with the 626 Pneumatic Tool System: remove the crimping head from the Straight Action Hand Tool (SAHT) Assembly, order SAHT Adapter Part No. 217201-1, Adapter Holder Part No. 356304-1 (with ratchet) or 189928-1 (without), and Power Unit Part No. 189721-1 (hand actuated) or 189722-1 (foot actuated).
⁷Standard reeling of strip form contacts.
⁸Commercial PRO-CRIMP II hand tool for field repair only. **Note:** Die Set can be adapted for use with the 626 Pneumatic Tool System.

‡Single contact, free-air test current is not to be construed as contact rating current. Use only for testing. Refer to contact current carrying capability information on page 7.
Insertion Tool Part No. 91002-1 (for insulation diameters .070 [1.78] or less), **No. 200893-2** (for insulation diameters .090 [2.29] max.).
Extraction Tool Part No. 305183. (Instruction Sheet 408-1216)
***Call the Technical Support Center at 1-800-522-6752 for Automatic Machine Applicator Part Numbers.

Signal Contacts (Continued)

Type III+, Posted
(Replacement Contacts,
See Note Below)



Pin



Socket

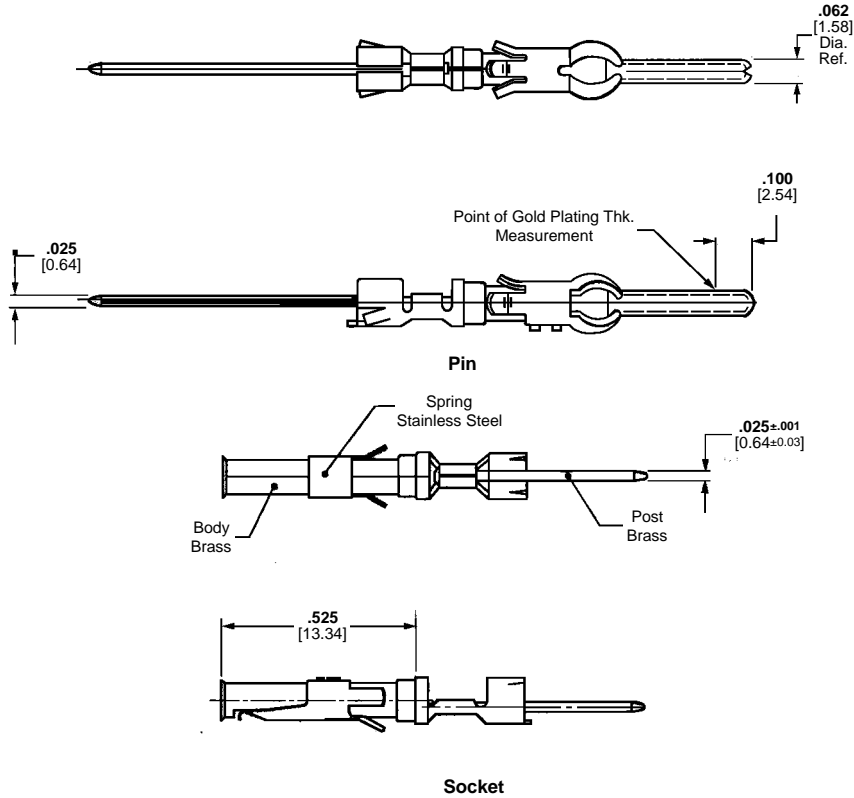

Material

Contact Body and Post—Brass
Retention Spring—Stainless steel

Finish

See chart.

Contact Size 16—Pin Diameter .062 [1.57] (Test Current, 13 Ampere)‡

Termination Method	Post Configuration	Contact Finish	Loose Piece Contact No.					
			3 Termination High Post		2 Termination High Post		1 Termination High Post	
			Pin	Socket	Pin	Socket	Pin	Socket
Wrap-Type	.025 x .025 0.64 x 0.64	Sel. Gold/Nickel ¹	66460-9	66461-9	66460-8	66461-8	66460-7	66461-7
		Gold/Nickel ²	66460-6	66461-6	—	66461-5	66460-4	66461-4
		Bright Tin-Lead	66460-3	66461-3	66460-2	66461-2	66460-1	66461-1
	.045 x .045 1.14 x 1.14	Sel. Gold/Nickel ¹	66471-9	66473-9	—	—	66471-7	66473-7
		Bright Tin-Lead	66471-3	66473-3	—	—	66471-1	66473-1
	.031 x .062 0.79 x 1.57	Sel. Gold/Nickel ¹	66470-9	—	—	—	66470-7	—
TERMI-POINT Clip	.031 x .062 0.79 x 1.57	Sel. Gold/Nickel ¹	66468-9	66459-9	—	—	—	—

¹Gold flash over .000050 [0.00127] nickel on entire contact, with .000030 [0.00076] gold to a distance of .200 [5.08] from mating end. Gold thickness controlled on socket O.D.

².000030 [0.00076] gold over .000050 [0.00127] nickel on contact body. Gold thickness controlled on socket O.D.

Posts plated tin-lead over copper.

Extraction Tool **Part No. 305183** (Instruction Sheet 408-1216)

Insertion Tool **Part No. 200893-2**

Note: These contacts are used as replacement contacts for all posted connectors.

‡Single contact, free-air test current is not to be construed as contact rating current. Use only for testing. Refer to contact current carrying capability information on page 7.

Signal Contacts (Continued)

Type III+, Crimp, Snap-In

Contact Size—16
Pin Diameter—.062 [1.57]

Material and Finish

Contact Body—Copper alloy, plated tin or gold

Spring—Stainless steel

Grounding Pin

(make first - break last)

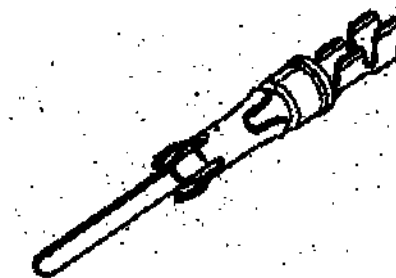

Related Product Data

Application Tooling—Pages 90, 91

Wire Size Range		Ins. Dia. Range ¹	Contact Finish	Grounding Pin Part No.		Strip Form Applicator Part No.	Loose Piece Hand Tool Part No.
[mm ²]	AWG			Strip Form	Loose Piece		
0.12-0.2	26-24	.035-.055 0.89-1.4	Tin-Lead	164159-3	164162-1	—	90066-7 ⁵ or 58495-1*
			Sel. Gold/Nickel ⁴	164159-4	164162-2		
0.2-0.6	24-20	.045-.070 1.14-1.78	Bright Tin-Lead	164160-3	164163-1	466323-□*** or 466907-2***	90066-7 ⁵ or 90067-4 ⁵ or 58495-1*
			Sel. Gold/Nickel ⁴	164160-4	164163-2		
0.8-1.4	18-16	.078-.098 1.98-2.49	Tin-Lead	164161-3	164164-1	466741-□*** or 680114-3***	90067-5 ⁵ or 90067-4 ⁵ or 58495-1*
			Sel. Gold/Nickel ⁴	164161-4	164164-2		

¹Overall insulation crimp diameter, including crimp barrel, must not exceed .125 [3.18].

⁴Gold flash over .000030 [0.00076] min. nickel on entire contact, with .000030 [0.00076] gold in contact area.

⁵To use with the 626 Pneumatic Tool System: remove the crimping head from the Straight Action Hand Tool (SAHT) Assembly, order SAHT Adapter **Part No. 217201-1**, Adapter Holder **Part No. 356304-1** (with ratchet) or **189928-1** (without), and Power Unit **Part No. 189721-1** (hand actuated) or **189722-1** (foot actuated).

*Commercial PRO-CRIMPER II hand tool for field repair only. **Note:** Die Set can be adapted for use with the 626 Pneumatic Tool System.

***Call the Technical Support Center at 1-800-522-6752 for Automatic Machine Applicator Part Numbers.

Extraction Tool Part No. 725840-1

Signal Contacts (Continued)

Type III+, Solder Versions



Pin



Socket

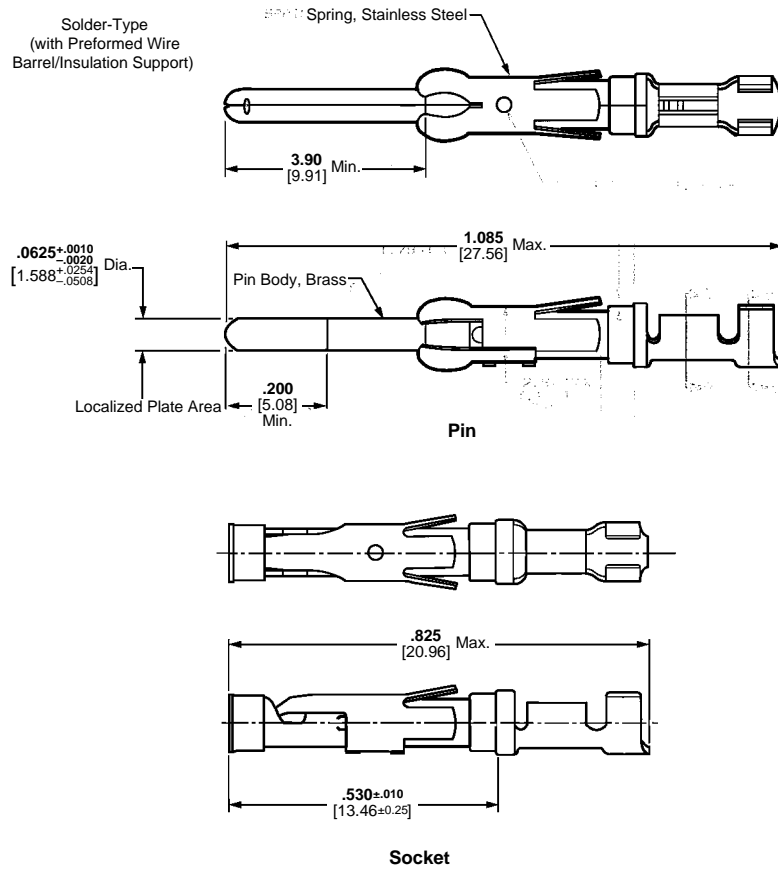

Material

Contact Body and Tab—Brass

Retention Spring—Stainless steel

Finish

See chart on Page 35

Signal Contacts (Continued)

Type III+, Solder Versions
(Continued)



Pin



Socket

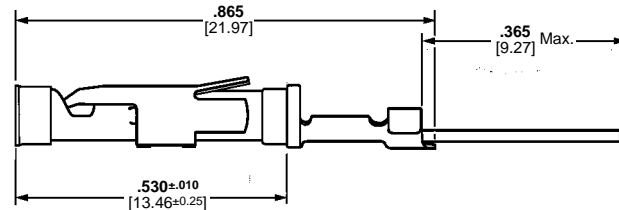
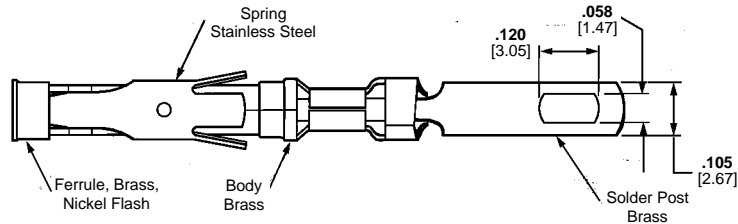
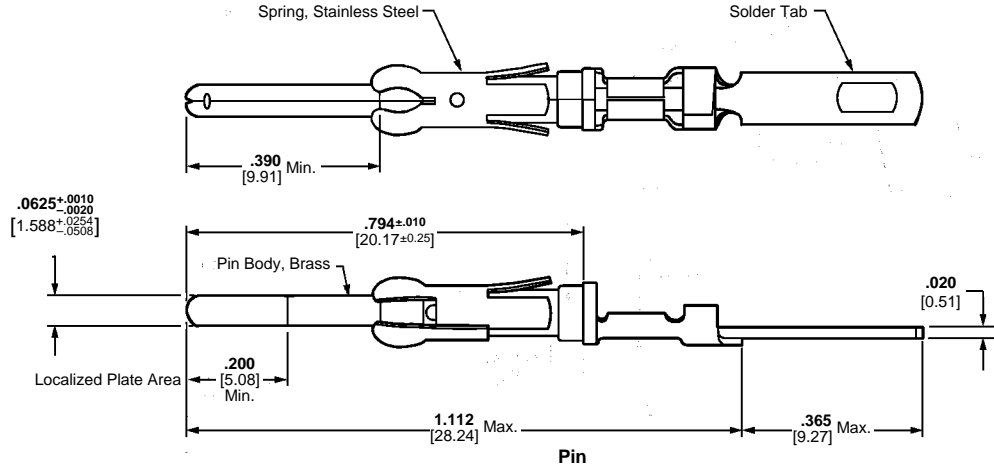

Socket

Material

Contact Body and Tab—Brass

Retention Spring—Stainless steel

Finish

See chart.

Contact Size 16—Pin Diameter .062 [1.57] (Test Current, 13 Ampere)‡

Wire Size Range		Contact Finish	Loose Piece Contact No.	
AWG	[mm ²]		Pin	Socket
26-20	0.12-0.6	Gold/Nickel ¹	66182-1	66183-1
18-16	0.8-1.4	Gold/Nickel ¹	66180-1	66181-1
Solder Tab		Duplex ²	202236-1	202237-1
		Bright Tin-Lead ³	202236-2	202237-2

¹0.000030 [0.00076] gold in mating area over .000050 [0.00127] nickel.

²Duplex plated .000030 [0.00076] gold in mating area over .000050 [0.00127] nickel on contact body; bright tin-lead on solder tab.

³Bright tin-lead on entire contact.

Note: These contacts can be used in Multimatch contact cavities of all connector housings.

‡Single contact, free-air test current is not to be construed as contact rating current. Use only for testing.

Refer to contact current carrying capability information on page 7.

Extraction Tool **Part No. 305183** (Instruction Sheet 408-1216)

Power Contacts

Type I, Crimp, Snap-In



Pin



Socket

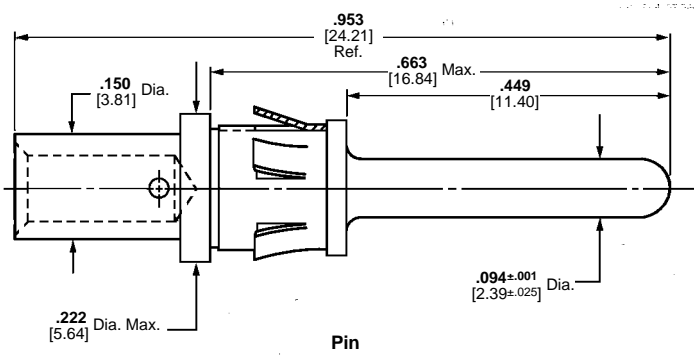

Pin

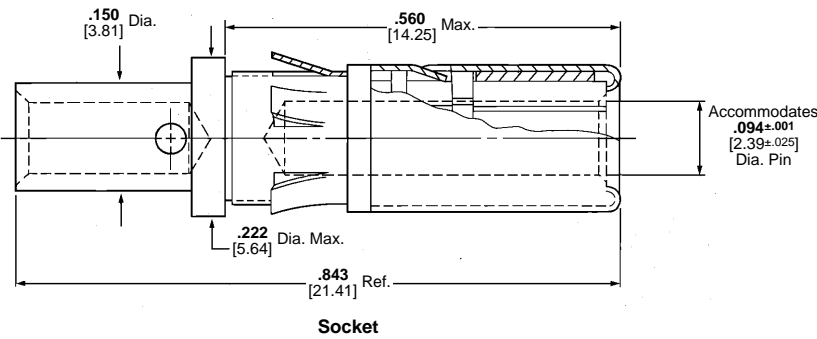

Socket

Power Contacts

Material

Contact Body—Bronze
Retention Spring—Beryllium copper

Finish

Contact Body—.000030 [0.00076] gold over .000050 [0.00127] nickel. Gold thickness controlled on socket O.D.
Retention Spring—Nickel plated

Related Product Data

Application Tooling—Pages 90, 91

Technical Documents

108-10108 Product Specification
114-10037 Application Specification

Size 12—Pin Diameter .094 [2.39] (Test Current, 23 Ampere)‡

Wire Size Range		Loose Piece Contact No.		Tooling Part No.	
AWG	[mm ²]	Pin	Socket	Dies for Pneumatic Tool*	Hand Tool
18-16	0.8-1.4	202421-1	202418-1	90122	90121
14-12	2-3	202422-1	202417-1	90122	90121

*Use hand actuated Power Unit **Part No. 189721-2** or foot actuated Power Unit **Part No. 189722-2**. Both units require "C" Head Die Set Adapter **Part No. 318161-1** and an Adapter Holder **Part No. 356304-1** (with ratchet) or **Part No. 189928-1** (without ratchet). Request Catalog 124208 for more information on the 626 Pneumatic Tool System.

‡Single contact, free-air test current; not to be construed as contact rating current. Use only for testing. Refer to contact current carrying capability information, page 7.

Extraction Tool **Part No. 305183-8** (Instruction Sheet 408-1216)

High Current Upgrade

Power Contacts (Continued)

Type II and Type III+, Size 16

The Multimate features of the High Current Size 16 contact have been designed to fit into the existing AMP Connectors such as CPC (Circular Plastic Connector), CMC (Circular Metal-Shell Connector), G Series, M Series, Econoseal Metrimate Square Grid and Drawer Connector housings. An initial T-Rise test in free air has shown a **23 amp** capability with a 30° T-Rise. The contact may be crimped onto 14 AWG wire with an AMP hand tool P/N 601967-1. Use turret TH502 (1-601967-6) for the pin and turret TH501 (1-601967-5) for the socket.

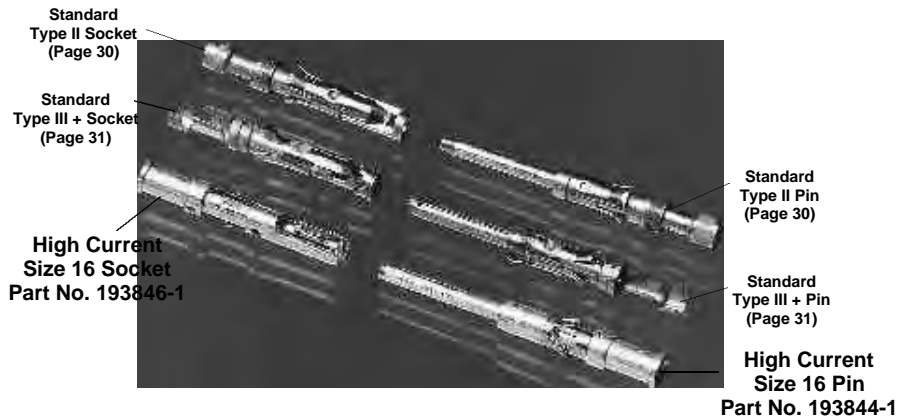

Material

Pin Body — Leaded brass

Socket Body — Copper alloy

Louvertac Band — Beryllium copper

Retention Spring — Stainless steel

Finish

Body — Silver

Louvertac Band — Gold



Extraction Tool Part No. 305183
(Instruction Sheet 408-1216)

Current-Carrying Capacity. The graph shows current-carrying capacity versus temperature rise for a fully energized 6 position Metrimate Square Grid plug P/N 207152-1 and receptacle P/N 207153-1. These initial representative amperage ratings were conducted with 14 AWG wires that were 2 feet long.

Current Rating for 30°C Temperature Rise 100% Energized
6 Circuit Connector (Wire-to-Wire)

TEMPERATURE RISE VS. CURRENT

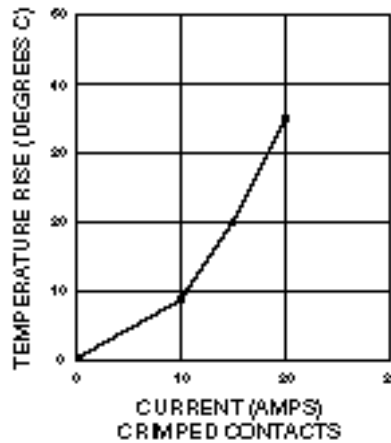

- Notes:**
1. High Current contacts with Louvertac bands are **not** intermateable with any other contact.
 2. Additional information on CPC and CMC connectors is available in Tyco Electronics Catalog No. 82021.
 3. Additional information on G Series connectors is available in Tyco Electronics Catalog No. 82046.
 4. Additional information on M Series connectors is available in Tyco Electronics Catalog No. 82003.
 5. Additional information on Metrimate connectors is available in Tyco Electronics Catalog No. 82045.
 6. Additional information on Econoseal connectors is available in Tyco Electronics Catalog No. 82057.
 7. Additional information on LGH connectors is available in Tyco Electronics Catalog No. 82024.

Power Contacts (Continued)

Type XII, Precision Formed, Crimp, Snap-In

Material

Copper

Finish

- A—Tin-lead
- B—.000030 [0.00076] selective gold over .000030 [0.00076] nickel
- C—.000100 [0.00254] silver plated contacts with lubricant added

Test Current Rating

Silver or Gold—35 amperes ‡

Tin Lead—15 amperes ‡

‡Single contact, free-air test current; not to be construed as contact rating current. Use only for testing. Refer to contact current carrying capability information, page 7.

Related Product Data

Application Tooling—Pages 90, 91

Technical Documents—Pages 92, 93



Male



Female



Extraction Tool Part No. 91019-3

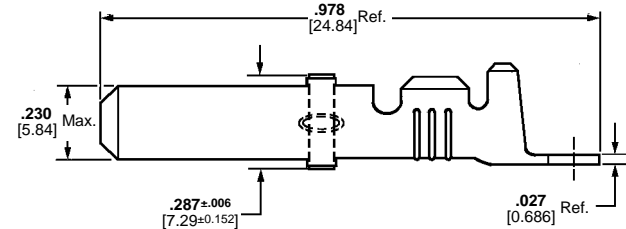
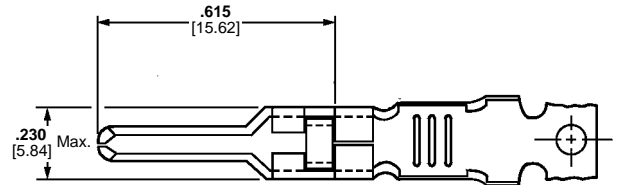

Male

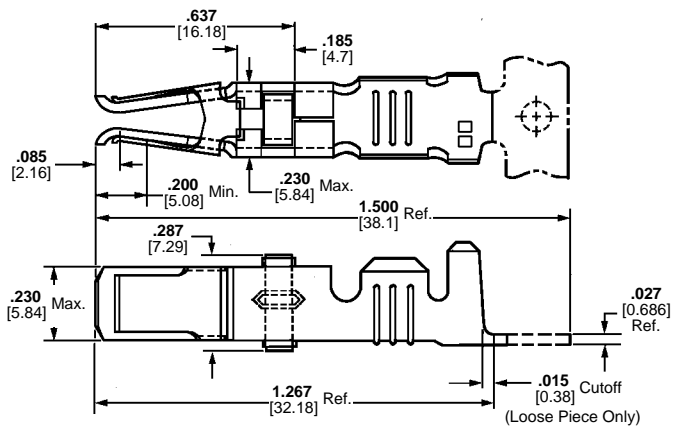

Female

Wire Size Range ¹	Ins. Dia. Range	Contact Finish	Strip Form Contact Part Nos.				Loose Piece		Tooling		
			Standard***		Heavy Duty Miniature**		Contact Part Nos.		Heavy Duty Miniature Applicator	Die Set for Hand Tool 69710-1 or 626 Pneumatic Tool System	
AWG	mm ²		Male	Female	Male	Female	Male	Female			
16 and 14-12	1.25-1.4 and 2-3	.135-.160 3.43-4.06	A	66255-1	66740-7	66255-5	1-66740-2	66261-1	66740-8	567455-□***	90145-23.7 and 90145-14.7
				66256-12	—	66256-5 ²	—	66262-12	—		
			B	66255-2	66740-5	66255-6	1-66740-1	66261-2	66740-6		
				66256-2 ²	—	66256-4 ²	—	66262-2 ²	—		
			C ⁵	66255-7	66740-1	66255-8	66740-9	66261-4	66740-2		
				66256-6 ²	—	66256-7 ²	—	66262-4 ²	—		
10	5-6	.190-.220 4.83-5.59	A	66253-1	66741-7	66253-5	1-66741-2	66259-1	66741-8	567021-□***	90140-17
				66254-12	—	—	—	66260-12	—		
			B	66253-2	66741-5	66253-6	1-66741-1	66259-2	66741-6		
				66254-2 ²	—	—	—	66260-2 ²	—		
			C ⁵	66253-4	66741-1	66253-8	66741-9	66259-4	66741-2		
				66254-4 ²	—	—	—	66260-4 ²	—		

¹Wire strip length—.281 [7.14].

²Ground contact.

³Die insert PartNo. 90145-2 is for crimping 16 AWG [1.25-1.4 mm²] wire.

⁴Die insert PartNo. 90145-1 is for crimping 14-12 AWG [2-3 mm²] wire.

⁵Recommended for high current/vibration applications where fretting corrosion is a problem.

⁷Die Set requires "C" Head Adapter Part No. 318161-1; Adapter Holder Part No. 356304-1 (with ratchet) or 189928-1 (without); and Power Unit Part No. 189721-2 (hand actuated) or 189722-2 (foot actuated).

Extraction Tool Part No. 91019-3

***Call the Technical Support Center at 1-800-522-6752 for Automatic Machine Applicator Part Numbers.

High Current Upgrade

Type XII, Crimp, Snap-In

The Multimate features of the High Current Type XII contact have been designed to fit into the existing AMP Connectors such as CPC (Circular Plastic Connector), CMC (Circular Metal-Shell Connector), G Series, and M Series housings. An initial T-Rise test in free air has shown a **60 amp** capability with a 30° T-Rise with 8 gage wires. The contact may be crimped onto 8 AWG wire with a Daniels Hand Tool M310 or AMP P/N 356114-1 and Positioner TP1068S or AMP P/N 356119-1.

Material

- Body** — Copper alloy
- Louvertac Band** — Beryllium copper
- Retention Spring** — Stainless steel
- Finish**
- Body** — Silver
- Louvertac Band** — Gold



**Extraction Tool
Part No. 224155-1**

Current-Carrying Capacity. The graph shows current-carrying capacity versus temperature rise for a fully energized 3 position CPC plug P/N 206037-2 and receptacle P/N 206036-2. These initial representative amperage ratings were conducted with 8 AWG wires that were 3 feet long.

Power Contacts (Continued)

Cable-to-Cable

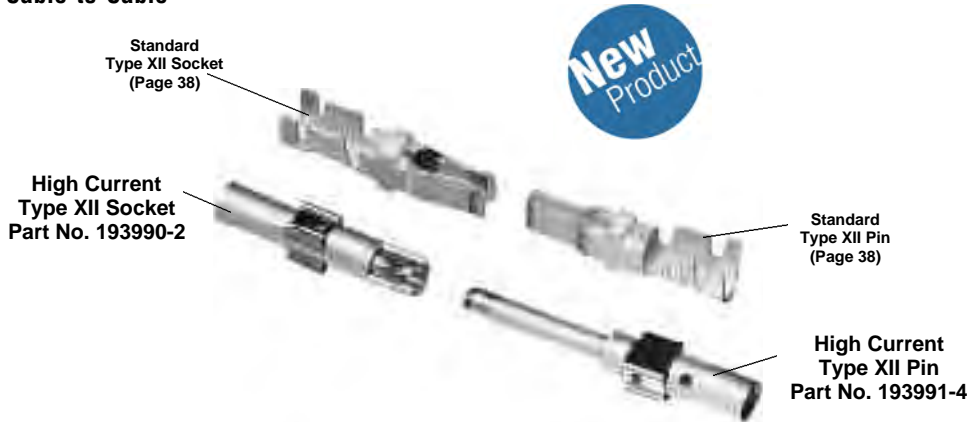

Current Rating for 30°C Temperature Rise 100% Energized

3 Circuit Connector (Wire-to-Wire)

TEMPERATURE RISE VS CURRENT

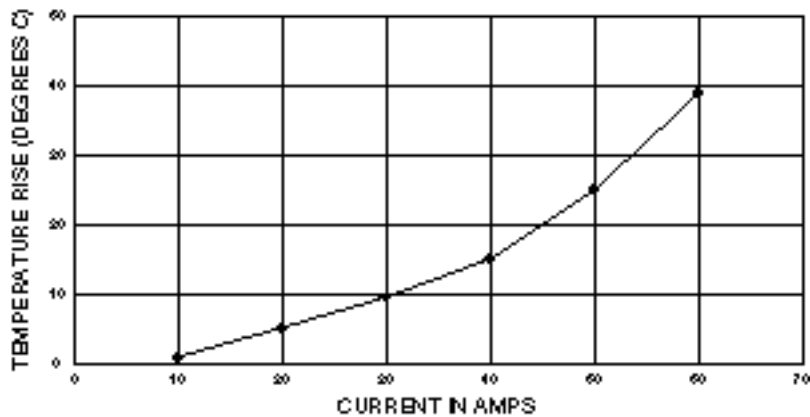

- Notes:**
1. High Current contacts with Louvertac bands are **not** intermateable with any other contact.
 2. Additional information on CPC and CMC connectors is available in Tyco Electronics Catalog No. 82021.
 3. Additional information on G Series connectors is available in Tyco Electronics Catalog No. 82046.
 4. Additional information on M Series connectors is available in Tyco Electronics Catalog No. 82003.
 5. Additional information on LGH connectors is available in Tyco Electronics Catalog No. 82024.

Coaxial Contacts

Subminiature, Crimp, Snap-In, Size 16



Pin



Socket

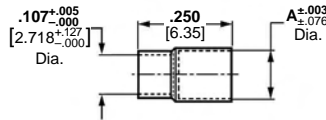
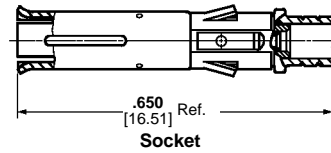
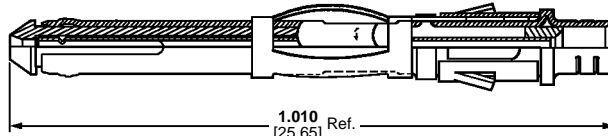

Ferrule
Part No. 225088-1 — A .120 [3.05] Dia.
225088-3 — A .123 [3.12] Dia.

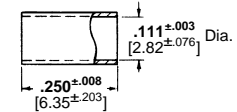

Ferrule
Part No. 1-332056-0

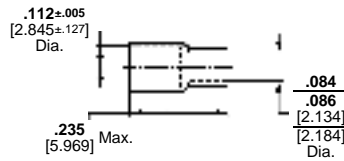

Ferrule
Part No. 1-332057-0

Selection Chart for Coaxial Cable

Material

- Outer Shell**—Brass per MIL-C-50
- Center Conductor**—Beryllium copper per QQ-C-533 (Pin); Brass per QQ-B-626 (Socket)
- Inner Dielectric**—Polypropylene
- Retention Spring**—Stainless steel per QQ-S-766
- Ferrule**—Copper per QQ-C-576 or ASTM-B-152 (1-332056-0)

Finish

- Outer Shell, Center Conductor**—See charts
- Ferrule**—Tin-lead per MIL-T-10727

Cable Size (RG/U)	Contact Finish	Loose Piece Contact No.		Ferrule Part No.	Tooling Part No.	
		Pin	Socket		Die Inserts for Hand Tool 69710-1 or Pneumatic Tool*	Hand Tool
178, 196	Gold/Nickel Gold/Copper ¹	226537-2	51565-2	1-332057-0	69690-2	69656-2
	Gold/Nickel Gold/Copper ²	—	51565-5			
196 (Double Braid)	Gold/Nickel Gold/Copper ¹	226537-2	51565-2	225088-1	—	69656-9
	Gold/Nickel Gold/Copper ²	—	51565-5			
174, 188, 316	Gold/Nickel Gold/Copper ¹	226537-1	51565-1	1-332056-0	69690	69656
	Gold/Nickel Gold/Copper ²	226537-4	51565-4			
174 (Double Braid)	Gold/Nickel Gold/Copper ¹	226537-1	51565-1	225088-3	—	69656-7
	Gold/Nickel Gold/Copper ²	226537-4	51565-4			
179, 187	Gold/Nickel Gold/Copper ¹	226537-1	51565-1	1-332056-0	69690-1	69656-1
	Gold/Nickel Gold/Copper ²	226537-4	51565-4			
187 (Double Braid)	Gold/Nickel Gold/Copper ¹	226537-1	51565-1	225088-1	—	69656-8
	Gold/Nickel Gold/Copper ²	226537-4	51565-4			
161	Gold/Nickel Gold/Copper ¹	226537-1	51565-1	1-332056-0	—	69656-5
	Gold/Nickel Gold/Copper ²	226537-4	51565-4			

*Use hand actuated Power Unit **Part No. 189721-2** or foot actuated Power Unit **Part No. 189722-2**. Both units require "C" Head Die Set Adapter **Part No. 318161-1** and an Adapter Holder **Part No. 356304-1** (with ratchet) or **Part No. 189928-1** (without ratchet). Request Catalog 124208 for more information on the 626 Pneumatic Tool System.

Extraction Tool **Part No. 305183**

Coaxial Contacts

Coaxial Contacts (Continued)

Subminiature, Crimp, Snap-In, Size 16
(Continued)

Selection Chart for Twisted Pair and Shielded Wire

Wire Size		Contact Finish	Loose Piece Contact No.		Ferrule Part No.	Tooling Part No.	
AWG	[mm ²]		Pin	Socket		Die Inserts for Hand Tool 69710-1 or Pneumatic Tool*	Hand Tool
30	0.05	Gold/Nickel Gold/Copper ¹	226537-3	51565-3	1-332057-0	69690-2	69656-2
28	0.08-0.09	Gold/Nickel Gold/Copper ¹	226537-3	51565-3	1-332057-0	69690	69656
28	0.08-0.09	Gold/Nickel Gold/Copper ¹	226537-3	51565-3	1-332057-0	69690-1 or 69690-2	69656-1 or 69656-2
26	0.12-0.15	Gold/Nickel ¹ Gold/Copper	226537-3	51565-3	1-332057-0	69690	69656
26	0.12-0.15	Gold/Nickel Gold/Copper ¹	226537-1	51565-1	1-332057-0	69690-3	69656-3
	(Shielded, .075 [1.91] Max. O.D.)	Gold/Nickel Gold/Copper ²	226537-4	51565-4			

1.000030 [0.00076] gold over .000050 [0.00127] nickel—outer shell and socket center conductor; .000030 [0.00076] gold over .000100 [0.00254] copper—pin center conductor.
 2.000050 [0.00127] gold over .000050 [0.00127] nickel—outer shell and socket center conductor; .000050 [0.00127] gold over .000100 [0.00254] copper—pin center conductor.

*Use hand actuated Power Unit **Part No. 189721-2** or foot actuated Power Unit **Part No. 189722-2**. Both units require "C" Head Die Set Adapter **Part No. 318161-1** and an Adapter Holder **Part No. 356304-1** (with ratchet) or **Part No. 189928-1** (without ratchet). Request Catalog 124208 for more information on the 626 Pneumatic Tool System.

Note: A ferrule is required for each pin and socket.
Extraction Tool Part No. 305183

Coaxial Contacts

Coaxial Contacts (Continued)

**Miniature, Crimp, Snap-In,
Size 12**



Pin



Socket



Ferrule

Retention Spring
Part No. 201142-1

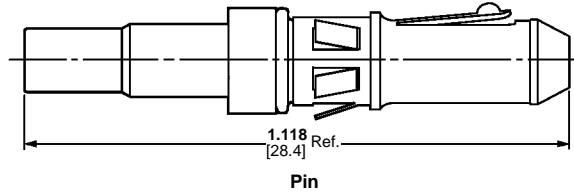
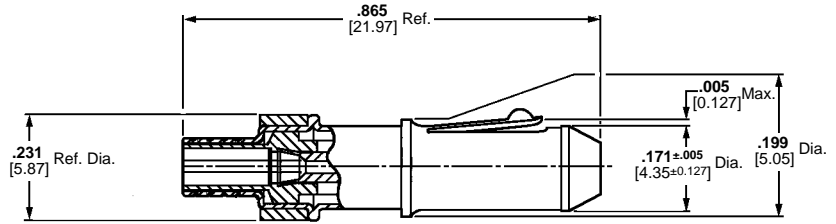

Pin

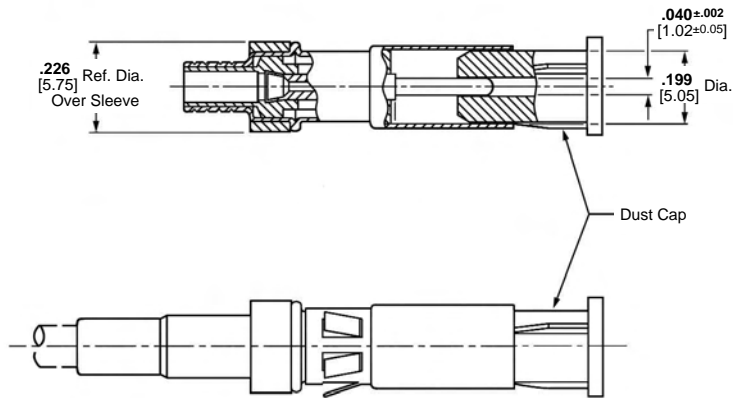

Socket

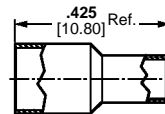

Ferrule

Material

Outer Shell—Brass per MIL-C-50

Center Conductor—Brass per QQ-B-626

Inner Dielectric—Polymethylpentene

Retention Spring—Beryllium copper per QQ-C-533

Ferrule—Copper per QQ-C-576

Finish

Outer Shell, Center Conductor—
See charts on next page

Retention Spring—Nickel per QQ-N-290

Ferrule—Tin-lead per MIL-T-10727
Extraction Tool **Part No. 305183-8**

Coaxial Contacts

**Miniature, Crimp, Snap-In,
Size 12**
(Continued)

Coaxial Contacts (Continued)

Selection Chart for Coaxial Cable

Cable Size (RG/U)	Contact Finish	Loose Piece Contact No.		Ferrule Part No.	Tooling Part No.	
		Pin	Socket		Die Inserts for Hand Tool 69710-1 or Pneumatic Tool*	Hand Tool
	Gold/Copper ²	—	201146-9			
58, 58A, 58B, 58C	Gold/Nickel ¹	201145-4	201146-4	328663	69220-2	45740-2
	Gold/Copper ²	—	201146-9			
174, 179A, 187, 21-598	Gold/Nickel ¹	201143-1	201144-1	328666	69227-2	45638-2
	Gold/Copper ²	—	201144-6			
180, 180A, 195, 21-597	Gold/Nickel ¹	201145-2	201146-2	328664	69222-2	45639-2
	Gold/Copper ²	1-201145-0	1-201146-0			
178, 178A, 196	Gold/Nickel ¹	201511-1	201512-1	328667	69373	69186-2
	Gold/Nickel ¹	201143-5	201144-5	328666	69227-2	45638-2
188	Gold/Copper ²	201143-7	201144-7			
122	Gold/Nickel ¹	201145-1	—	328664	69222-2	45639-2
188 Double Braid	Gold/Nickel ¹	201143-5	201144-5	221848-3	—	58290-1
316 Double Braid	Gold/Copper ²	201143-7	201144-7			
Special .125, .100, .066, .012DB	Gold/Nickel ¹	201143-1	201144-1	221848-3	—	58290-1

Selection Chart for Twisted Pair

Wire Size		Max. Ins. Dia. (Two Wires Combined)	Contact Finish	Loose Piece Contact No.		Ferrule Part No.	Tooling Part No.	
AWG	[mm ²]			Pin	Socket		Die Inserts for Hand Tool 69710-1 or Pneumatic Tool*	Hand Tool
24-22	0.2-0.4 (Stranded)	.115 2.92	Gold/Nickel ¹	201143-5	201144-5	328666	69672	45638-3
			Gold/Copper ²	201143-7	201144-7			
24-22	0.2-0.4 (Solid or Stranded)	.160 4.06	Gold/Nickel ¹	50079-1	50080-1	329029	69222-2	45639-2

Selection Chart for Shielded Wire

Shielded Wire		Contact Finish	Loose Piece Contact No.		Ferrule Part No.	Tooling Part No.	
AWG	No.		Pin	Socket		Die Inserts for Hand Tool 69710-1 or Pneumatic Tool*	Hand Tool
22	MIL-C-7078A, Type II	Gold/Nickel ¹	201145-4	201146-4	328663	69220-2	45740-2
		Gold/Copper ²	—	201146-9			

Selection Chart for Various Manufacturers' Cables

Cable Size		Dielectric O.D. (Max.)	Cable O.D. Range	Braid	Contact Finish	Loose Piece Contact No.		Ferrule Part No.	Tooling Part No.	
Type/AWG	[mm ²]					Pin	Socket		Die Inserts for Hand Tool 69710-1 or Pneumatic Tool*	Hand Tool
Brand-Rex T5788A 26 AWG	0.12-0.15	.106 2.69	.160 4.06	Single	Gold/Nickel ¹	201145-2	201146-2	328664	69222-2	45639-2
					Gold/Copper ²	1-201145-0	1-201146-0			
RAYCHEM 0030D1314 Army Ord. 11207177 32-26 AWG	0.03-0.15	.129 3.28	.122-.137 3.10-3.48	Single	Gold/Nickel ¹	—	201146-6	330587	—	69360-2

1.000030 [0.00076] gold over .000030 [0.00076] nickel.

2.000100 [0.00254] gold over .000100 [0.00254] copper.

*Use hand actuated Power Unit **Part No. 189721-2** or foot actuated Power Unit **Part No. 189722-2**. Both units require "C" Head Die Set Adapter **Part No. 318161-1** and an Adapter Holder **Part No. 356304-1** (with ratchet) or **Part No. 189928-1** (without ratchet). Request Catalog 124208 for more information on the 626 Pneumatic Tool System.

Note: A ferrule and retention spring (**201142-2**) are required for each pin and socket.

Standard Housings

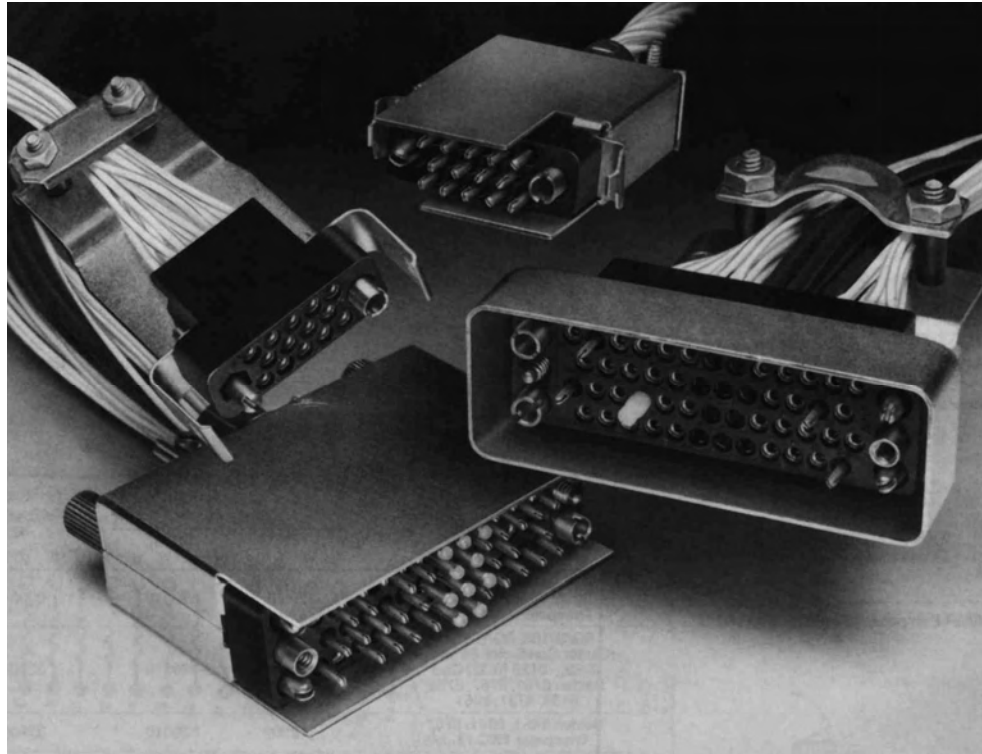

Standard connectors are furnished as unloaded housings that have Multimate contact cavities for accepting Type II, Type III+, and subminiature COAXICON crimp-type contacts, as well as Type III+ solder-type and posted contacts. All Multimate contacts are interchangeable in the same housing cavity.

Standard connector housings are available in sizes ranging from 6 thru 160 positions. They mate with each other, as well as posted connectors of a corresponding size for hand tool and semiautomatic machine wiring. See Posted Connector section.

Standard Housings (Continued)

6 Position

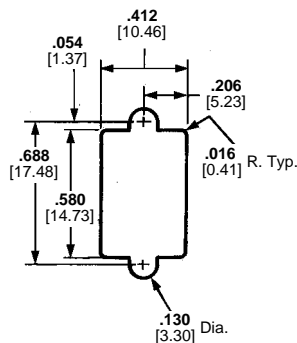

Recommended Panel Cutout

Plug Housing
Phenolic Part No. 202758-1
Diallyl Phthalate Part No. 202758-3

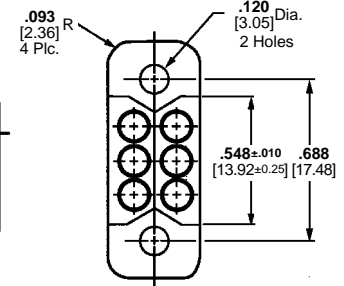
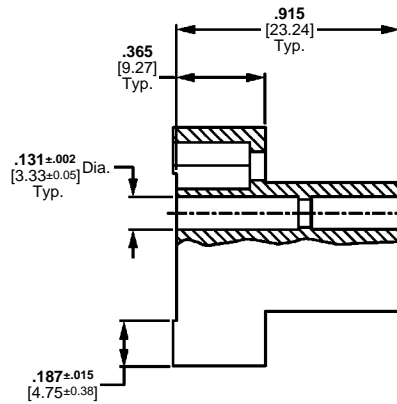
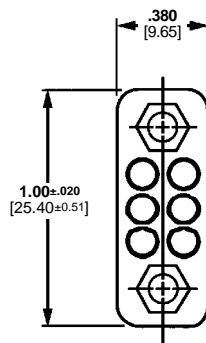

Receptacle Housing
Phenolic Part No. 202757-1
Diallyl Phthalate Part No. 202757-3

14 Position

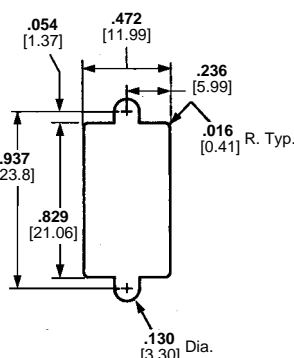

Recommended Panel Cutout

Plug Housing
Phenolic Part No. 201355-1

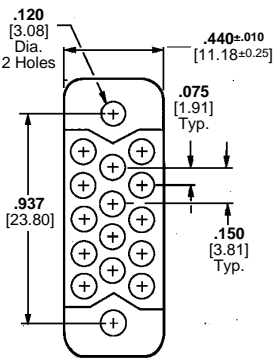
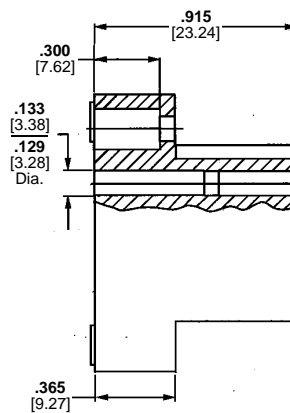
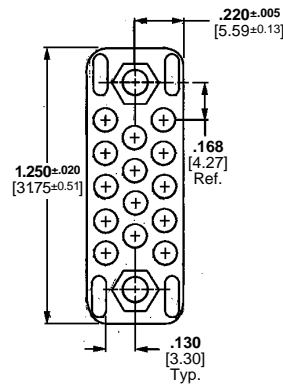

Receptacle Housing
Phenolic Part No. 201298-1
Diallyl Phthalate Part No. 201298-3

20 Position

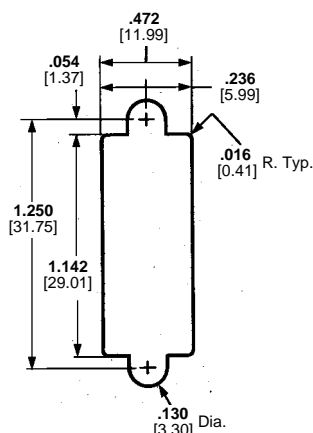

Recommended Panel Cutout

Plug Housing
Phenolic Part No. 201356-1
Diallyl Phthalate Part No. 201356-3

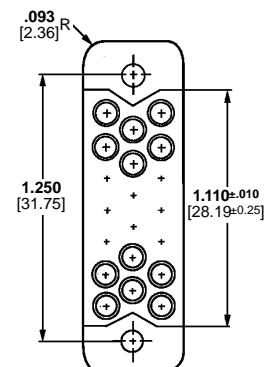
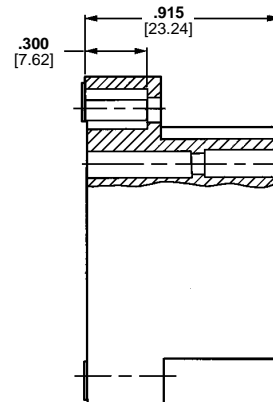
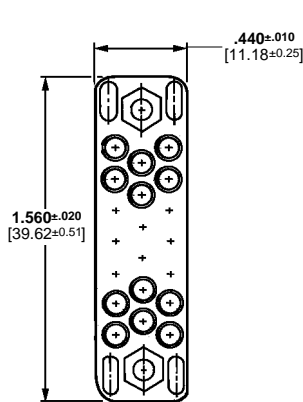

Receptacle Housing
Phenolic Part No. 200346-2
Diallyl Phthalate Part No. 200346-4

- Notes:**
1. All housings accept Type II, Type III+, and Subminiature COAXICON contacts.
 2. Pins and/or sockets may be used in any housing.
 3. Dimensions are ±.005 [0.127].
 4. Housing cavity identification are mirror image.

Standard Housings (Continued)

26 Position

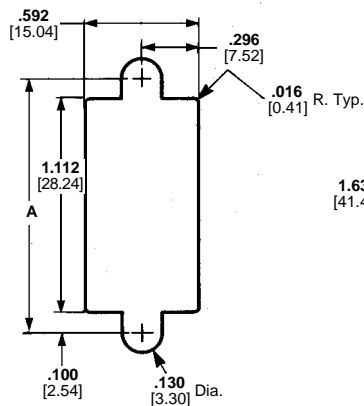

Recommended Panel Cutout

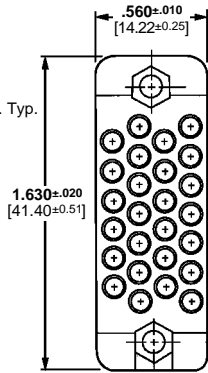

Plug Housing (Shown)

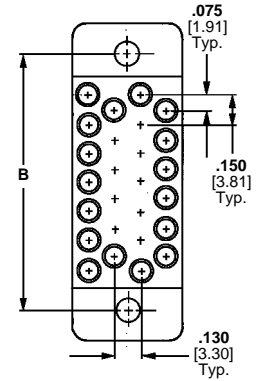
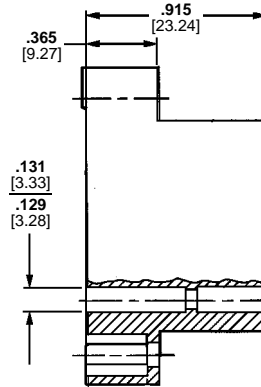

34 Position

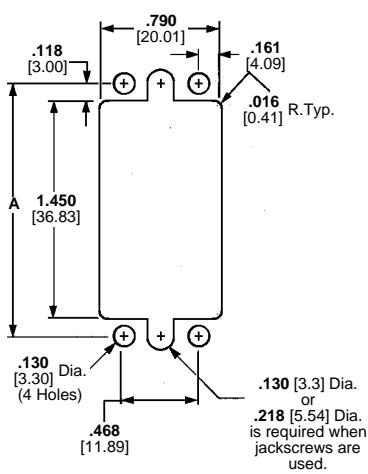

Recommended Panel Cutout

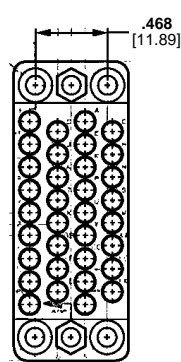

Plug Housing (Shown)

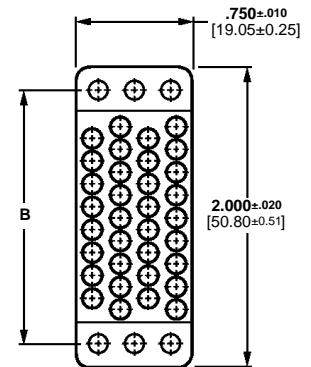
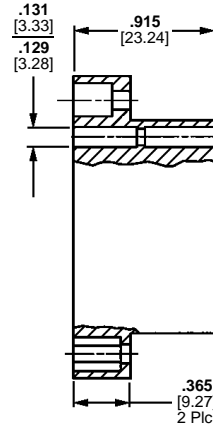

36 Position

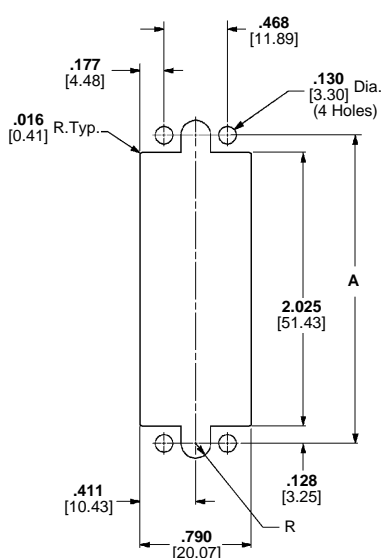

Recommended Panel Cutout

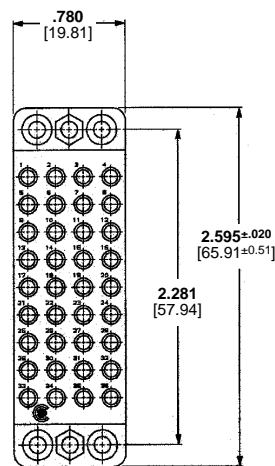

Plug Housing (Shown)

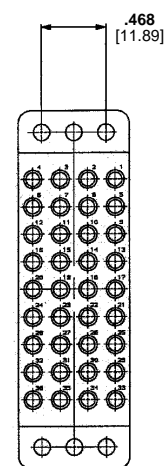
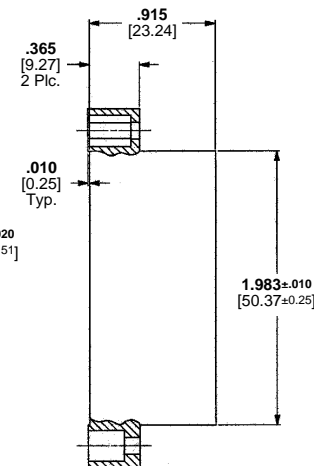

Standard Housings (Continued)

26, 34 and 36 Positions (Continued)

Related Product Data

Dimensions—Page 46

No. of Pos.	Housing Material	Plug Part Number	Dimension A	Receptacle Part Number	Dimension B
26	Phenolic	201359-1	1.312 33.32	200512-2	1.312 33.32
	Diallyl Phthalate	201359-3	1.322 33.58	200512-3	1.322 33.58
	Phenolic	1-201357-1	—	200838-2	—
34	Polyester	213799-1 (Modified)	1.686	213801-1 (Modified)	1.686
		213800-1 213800-2	42.82	213802-1 —	42.82
	Diallyl Phthalate	201357-3	1.696 43.08	200838-3	1.696 43.08
36	Phenolic	203956-2	2.281 57.94	—	—

- Notes:**
1. All housings accept Type II, Type III+, and Subminiature COAXICON contacts.
 2. Pins and/or sockets may be used in any housing.
 3. Dimensions are ± 0.005 [0.127].
 4. Housing cavity identification are mirror image.
 5. Versions also available with notch for robotic assembly. Contact Tyco Electronics Corporation.

41 Position

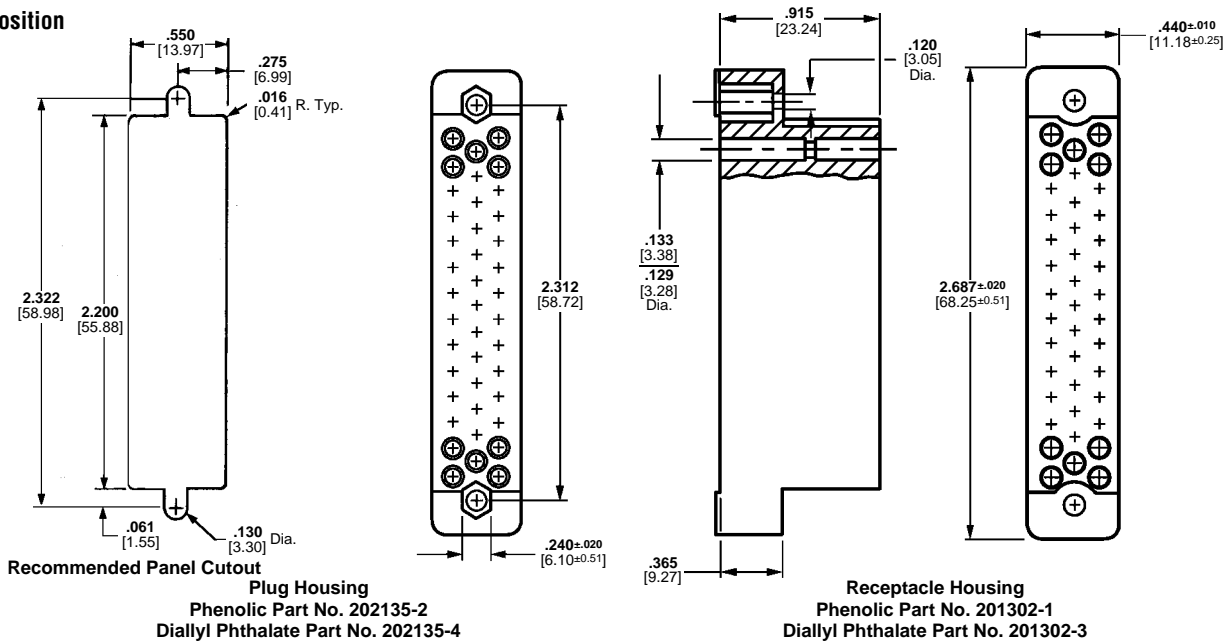

50 Position

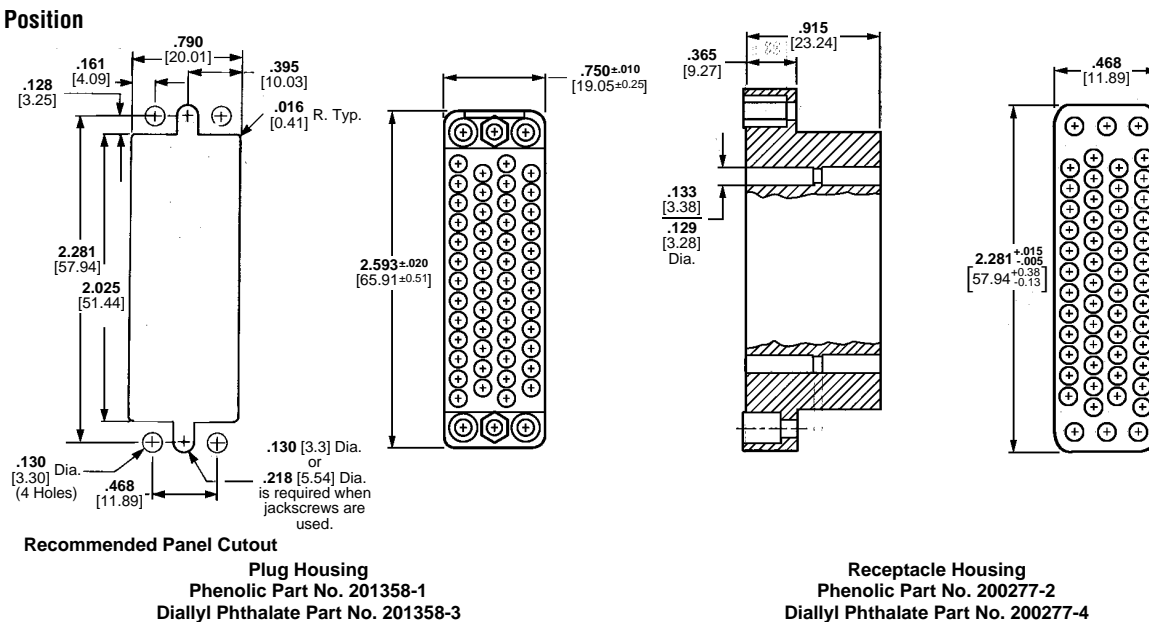

Dimensions are shown for reference purposes only.

Dimensions are in inches and millimeters unless otherwise specified. Values in brackets are metric equivalents.

Specifications subject to change.

Technical Support Center
1-800-522-6752
www.tycoelectronics.com

Standard Housings (Continued)

50 Position

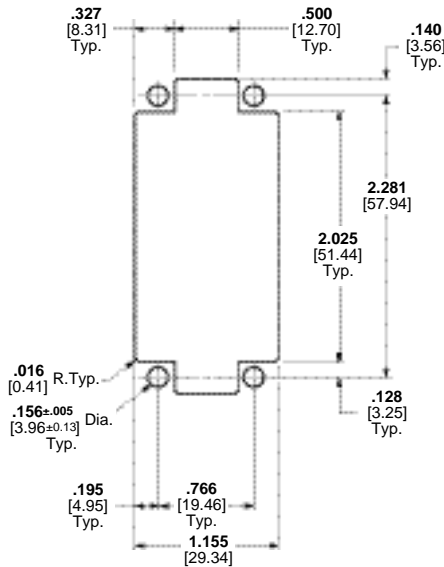

Recommended Panel Cutout

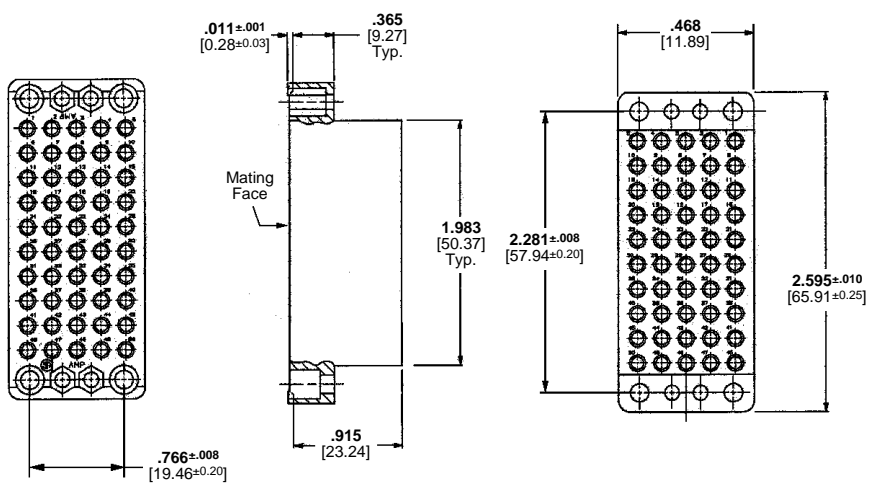

Plug Housing
Phenolic Part No. 203622-2
(Mating face contact cavities numbered left to right.)

Standard Housings

50 Position

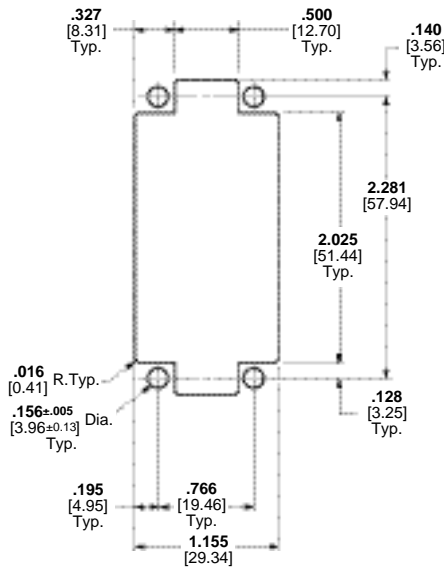

Recommended Panel Cutout

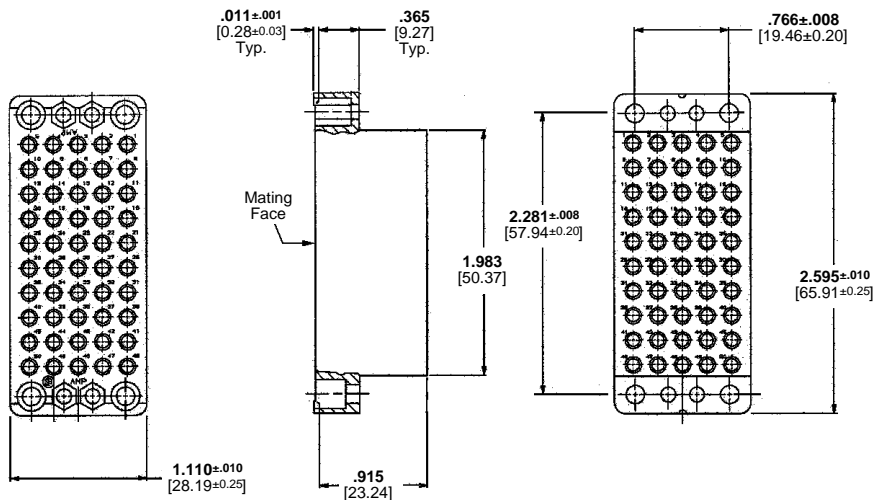

Plug Housing
Phenolic Part No. 205058-2
(Mating face contact cavities numbered right to left.)

Standard Housings (Continued)

75 Position

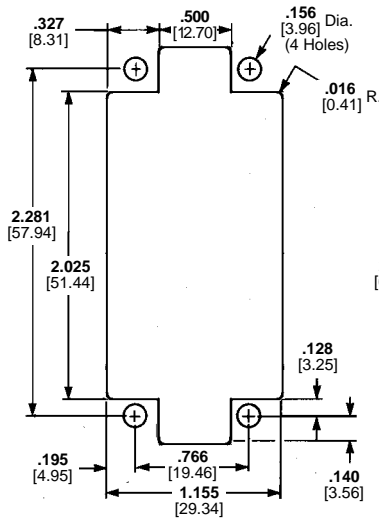

Recommended Panel Cutout

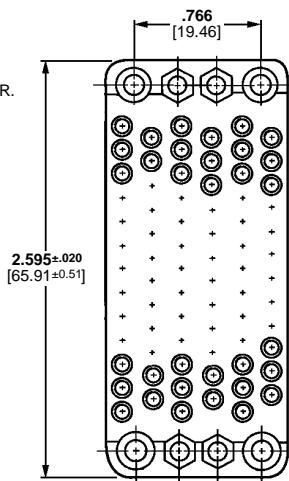

Plug Housing
Phenolic Part No. 201310-1
Diallyl Phthalate Part No. 201310-3

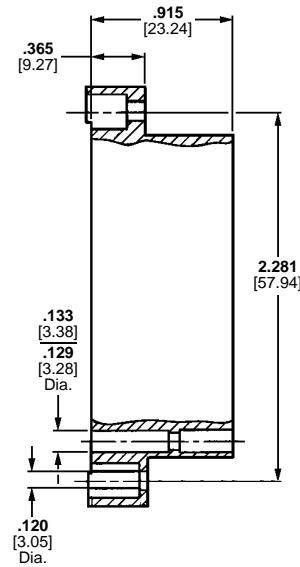

Receptacle Housing
Phenolic Part No. 201311-1
Diallyl Phthalate Part No. 201311-3

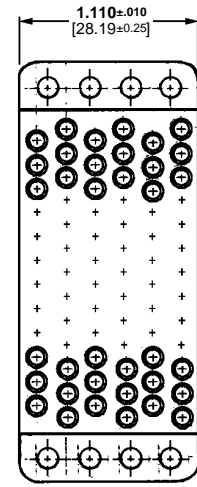

104 Position

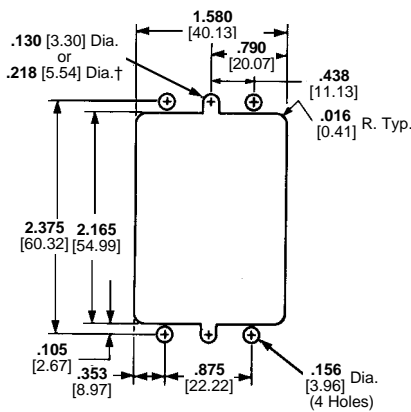

†.218 [5.54] diameter is required when jackscrews are used.

Recommended Panel Cutout

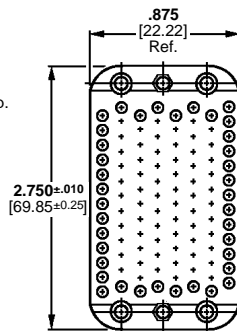

Plug Housing
Phenolic Part No. 201345-1

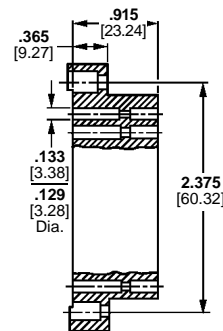

Receptacle Housing
Phenolic Part No. 201037-1

.375±.015 [9.53±0.38] R. Typ.

- Notes:**
1. All housings accept Type II, Type III+, and Subminiature COAXICON contacts.
 2. Pins and/or sockets may be used in any housing.
 3. Dimensions are $\pm .005$ [0.127].
 4. Housing cavity identification are mirror image.

Standard Housings (Continued)

104 CF Position
(with Center Fastener)

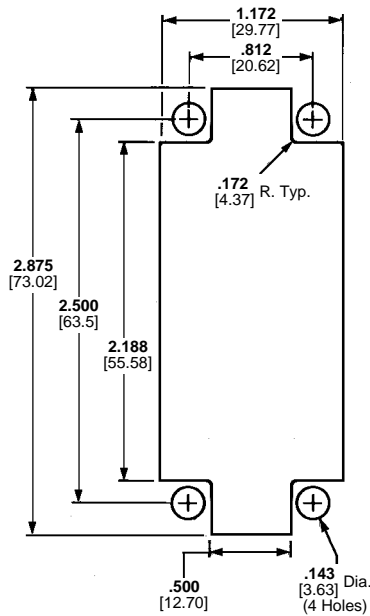

Recommended Panel Cutout

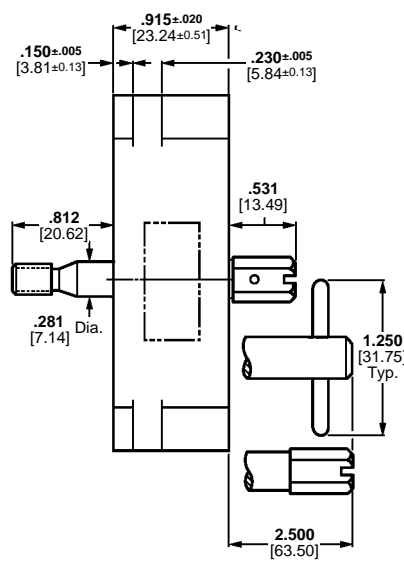

Plug Housing

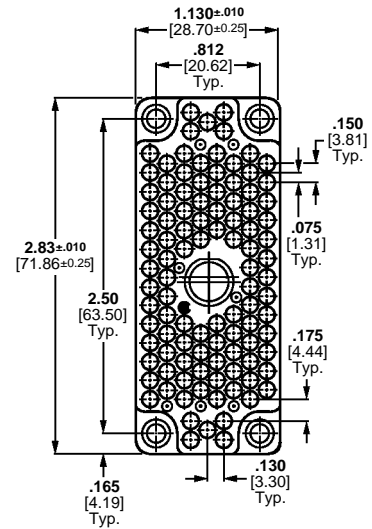

Receptacle Housing

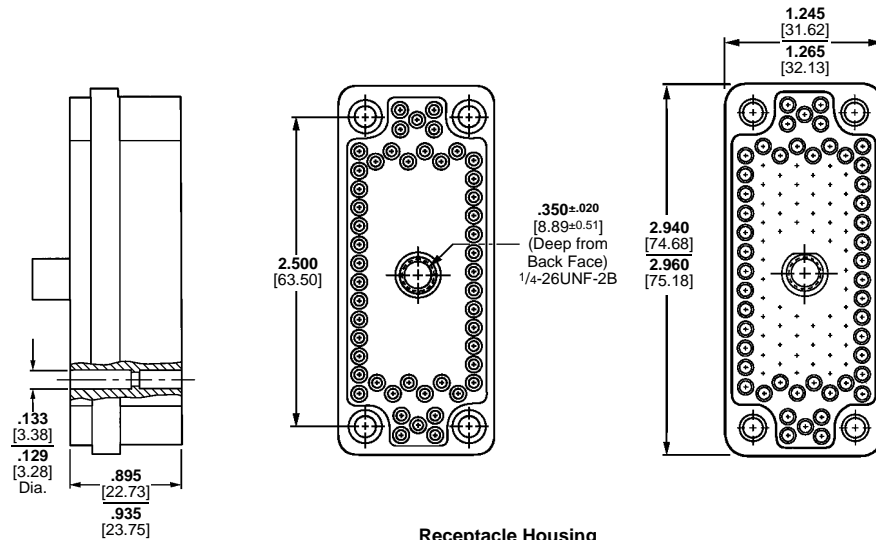

Center Fastener Description	Length	Plug Housing Part No.			Receptacle Housing Part No.		
		Phenolic	Diallyl Phthalate	Polyester	Phenolic	Diallyl Phthalate	Polyester
"T" Handle	2.500 63.50	201692-4	201692-3	1-201692-6			
Slotted Hex	2.500 63.50	201692-6	—	—	201532-4	201532-2	—
Slotted Hex	.531 13.49	201692-2	—	—			

- Notes:**
1. All housings accept Type II, Type III+, and Subminiature COAXICON contacts.
 2. Pins and/or sockets may be used in any housing.
 3. Dimensions are ±.005 [0.127].
 4. Housing cavity identification are mirror image.

Standard Housings (Continued)

160 CF Position
(with Center Fastener)

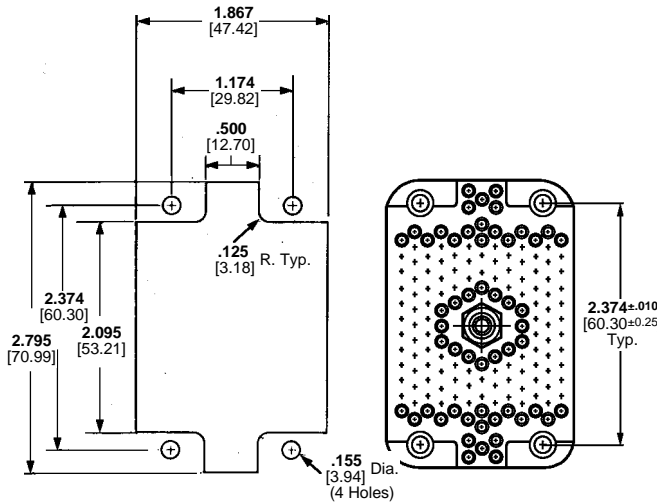

Recommended Panel Cutout

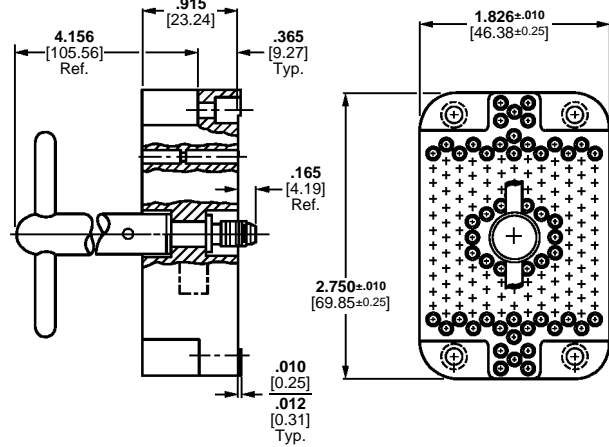

Plug Housing
Phenolic Part No. 202799-2
Diallyl Phthalate Part No. 202799-1

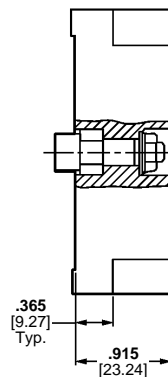
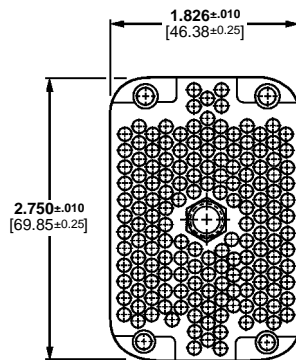

Receptacle Housing
Phenolic Part No. 202800-2
Diallyl Phthalate Part No. 202800-1

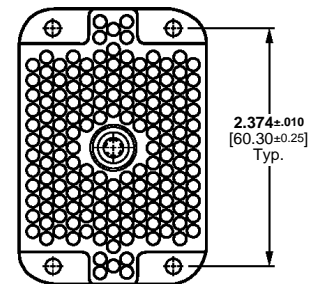

- Notes:**
1. All housings accept Type II, Type III+, and Subminiature COAXICON contacts.
 2. Pins and/or sockets may be used in any housing.
 3. Dimensions are ±.005 [0.127].
 4. Housing cavity identification are mirror image.

Posted Connectors

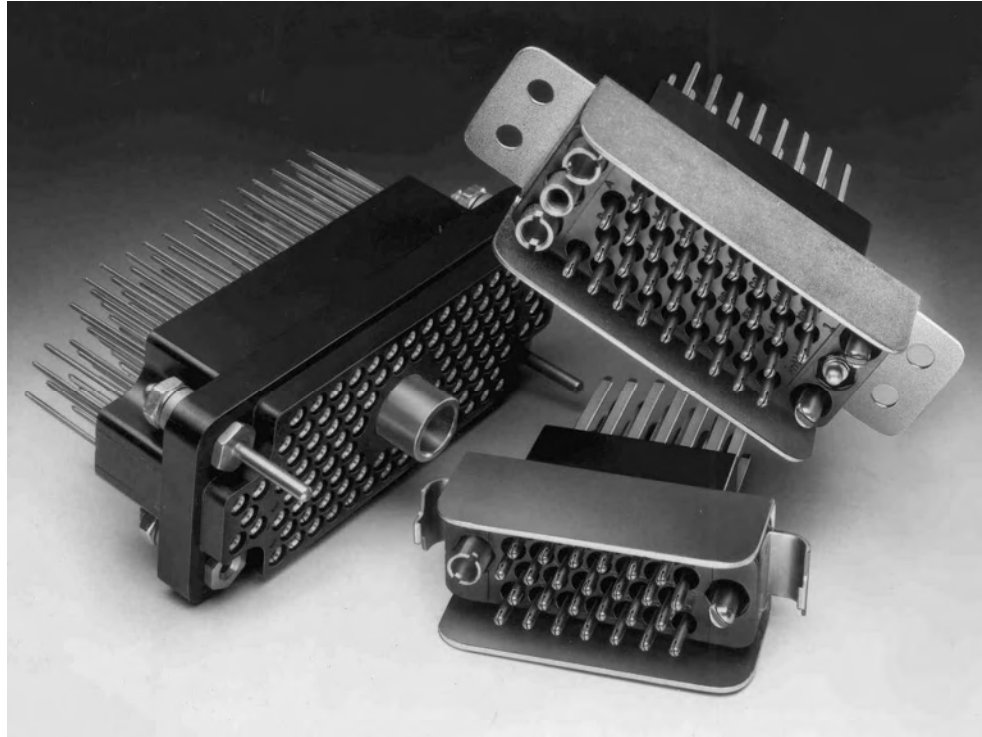

Posted connectors are furnished preloaded with Size 16, posted contacts (as shown on page 32) and are specifically designed to be wired with hand tools and semiautomatic machines. The cavity centerline spacing is too close to accommodate the heads and mandrels of fully automatic machines. Post configurations of the preloaded contacts are available for accepting TERMI-POINT Clip and wrap-type terminations.

Posted connector housings are made of black phenolic or diallyl phthalate and are available in sizes ranging from 6 thru 104 positions. They will mate with correspondingly sized standard connector (except .200 [5.08] grid) housings loaded with Size 16 crimp-type contacts. It is not recommended to mate two posted connectors. Since the preloaded posted contacts are rigid in the housing, mating two posted connectors, particularly of the larger sizes, would be difficult.

Posted connectors can be substituted for standard connectors in the Connector/Hardware Selection Charts, pages 10 to 25.

Tyco does not recommend the use of shields or strain relief clamps with posted connectors because of the potential of shorting.

Posted Connectors (Continued)

6 Position

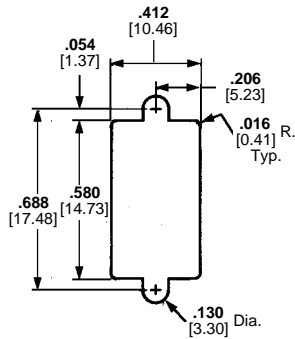

Recommended Panel Cutout

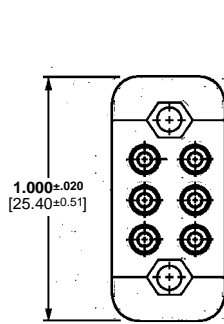

Plug Assembly

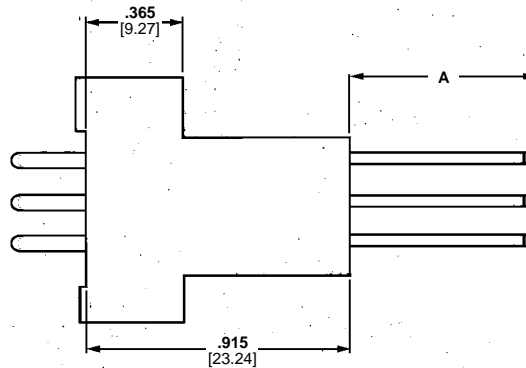

14 Position

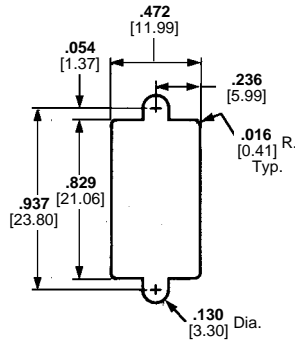

Recommended Panel Cutout

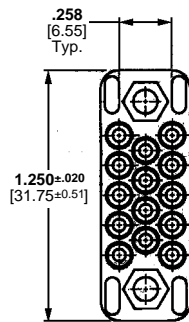

Plug Assembly

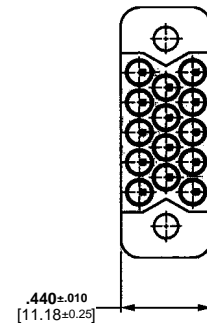
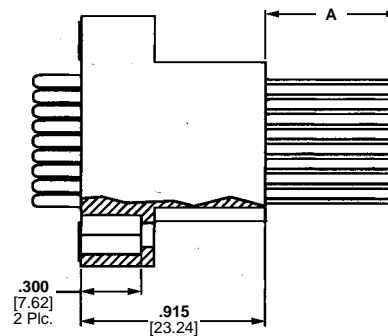

Receptacle Assembly

20 Position

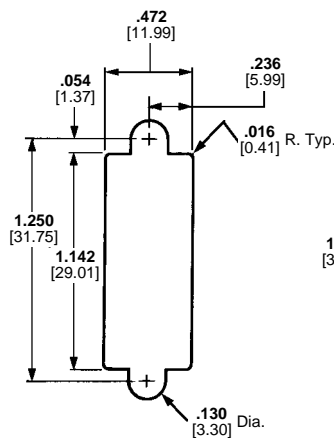

Recommended Panel Cutout

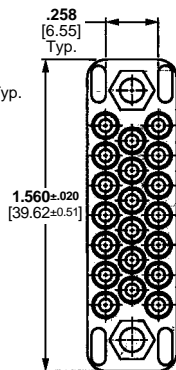

Plug Assembly

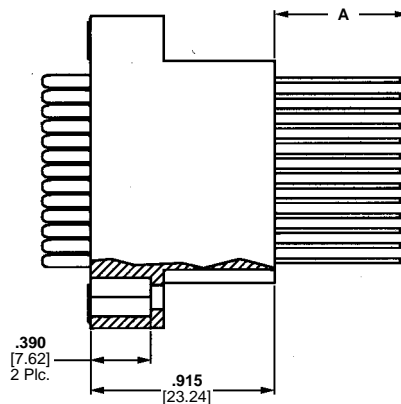

Posted Connectors (Continued)

26 Position

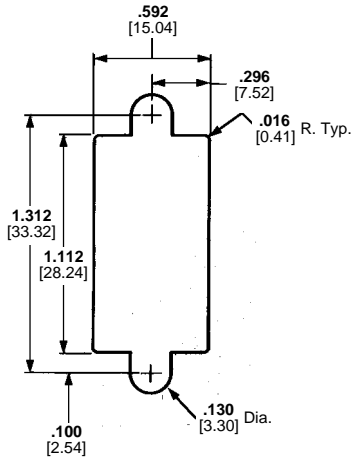

Recommended Panel Cutout

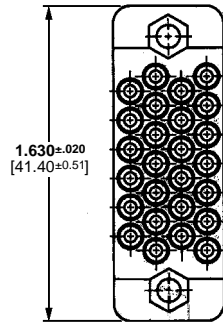

1.630±.020
[41.40±0.51]

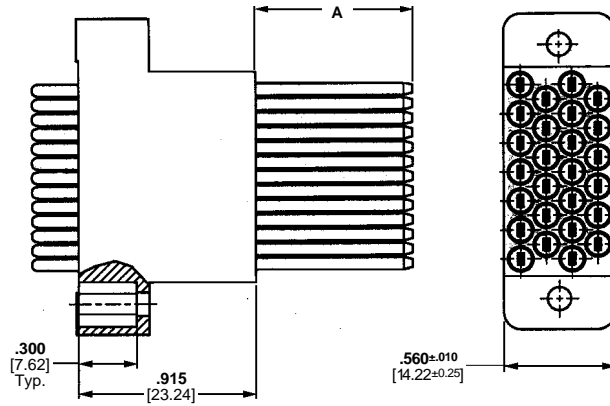

Plug Assembly

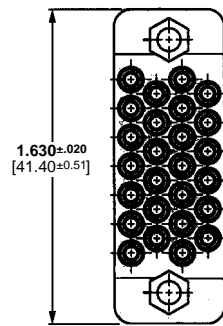

1.630±.020
[41.40±0.51]

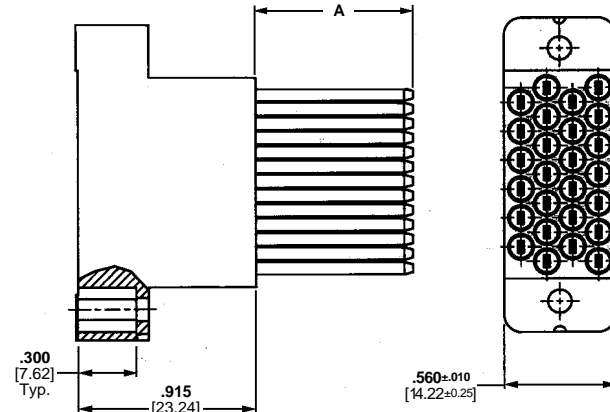

Receptacle Assembly

Plug and Receptacle Assemblies

No. of Pos.	Termination Method	Post Configuration	A Dimension	Contact Finish	Plug Assembly Part No.	Receptacle Assembly Part No.
6	Wrap Type	.025 x .025 0.64 x 0.64	.659 16.74	Sel. Gold/Nickel ¹	205507-1	—
14	Wrap Type	.025 x .025 0.64 x 0.64	.659 16.74	Sel. Gold/Nickel ¹	205317-1	—
			.261 6.63		—	3-205508-1
20	Wrap Type	.025 x .025 0.64 x 0.64	.659 16.74	Sel. Gold/Nickel ¹	205509-1	—
26	TERMI-POINT Clip	.031 x .062 0.79 x 1.57	.810 20.57	Sel. Gold/Nickel ¹	1-205512-3	1-205511-3

¹Gold flash over .000050 [0.00127] nickel on entire contact, with .000030 [0.00076] gold to a distance of .200 [5.08] from mating end. Posts are plated tin-lead over copper.

- Notes:**
1. Posted connectors listed above have black phenolic housings.
 2. Replacement contacts are shown on page 32.
 3. These posted connectors mate with standard connector housings shown on pages 45-47.

Posted Connectors (Continued)

34 Position

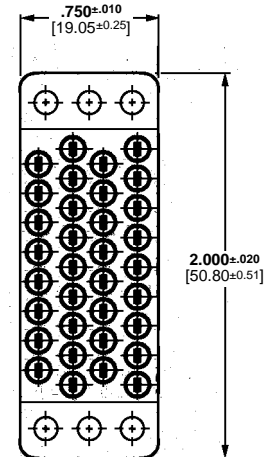
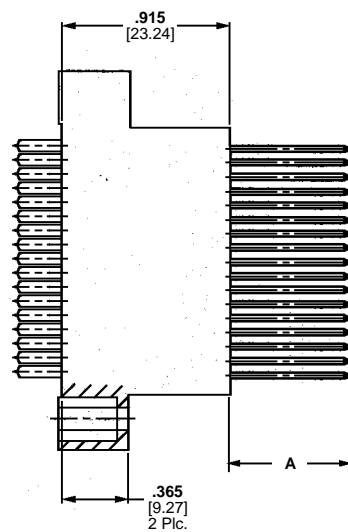
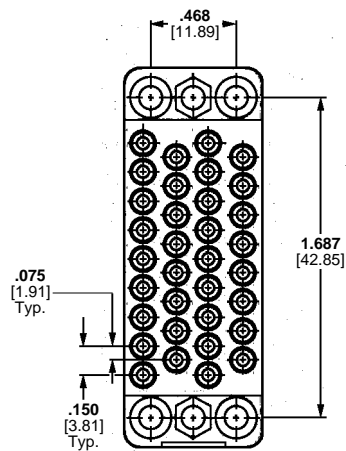

Plug Assembly

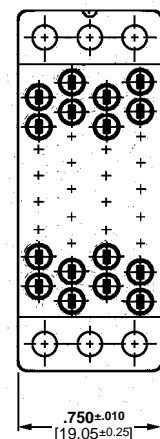
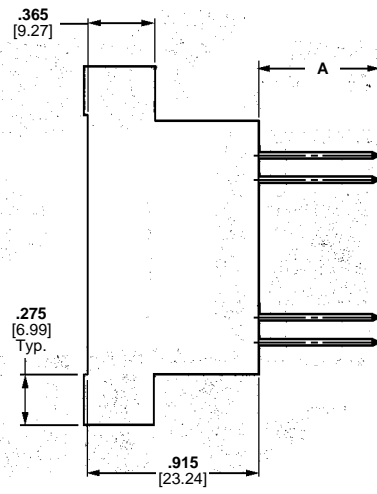
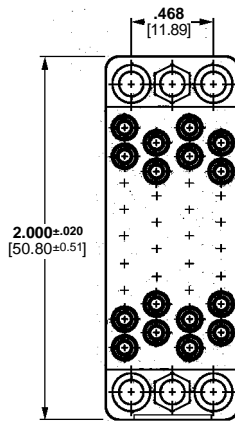
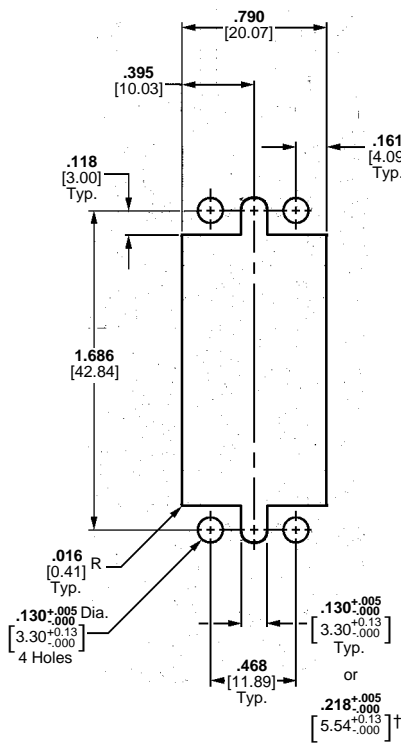

Receptacle Assembly

†.218 [5.54] diameter is required when jackscrews are used.

Recommended Panel Cutout

Posted Connectors (Continued)

50 Position

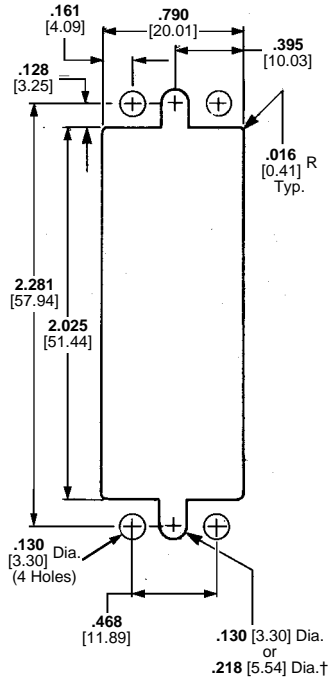

Recommended Panel Cutout

†.218 [5.54] diameter is required when jackscrews are used.

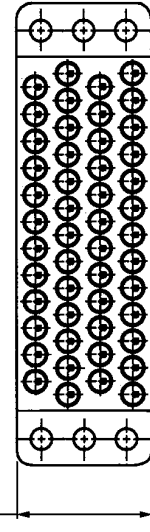
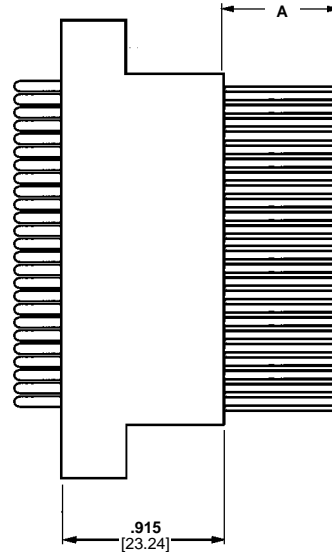
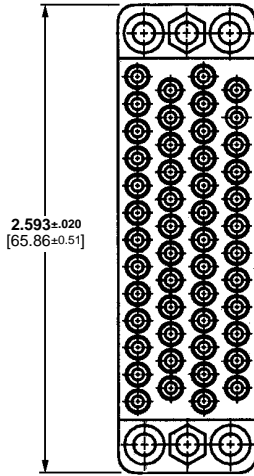

Plug Assembly

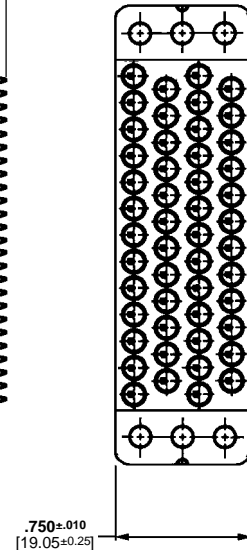
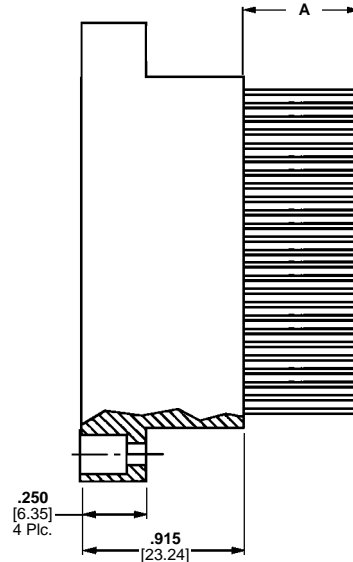
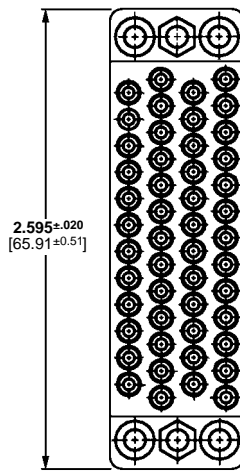

Receptacle Assembly

Plug and Receptacle Assemblies

No. of Pos.	Termination Method	Post Configuration	A Dimension	Contact Finish	Plug Assembly Part No.	Receptacle Assembly Part No.
34	Wrap Type	.025 x .025 0.64 x 0.64	.659 16.74	Sel. Gold/Nickel ¹	205361-1	205505-1
			.261 6.63	Sel. Gold/Nickel ¹	—	3-205505-1
50	Wrap Type	.025 x .025 0.64 x 0.64	.659 16.74	Sel. Gold/Nickel ¹	205156-1	205514-1
			.261 6.63	Sel. Gold/Nickel ¹	—	3-205514-1

¹Gold flash over .000050 [0.00127] nickel on entire contact, with .000030 [0.00076] gold to a distance of .200 [5.08] from mating end. Posts are plated tin-lead over copper.

- Notes:**
- Posted connectors listed above have black phenolic housings.
 - Replacement contacts are shown on page 32.
 - These posted connectors mate with standard connector housings shown on pages 46 and 47.

Posted Connectors (Continued)

75 Position

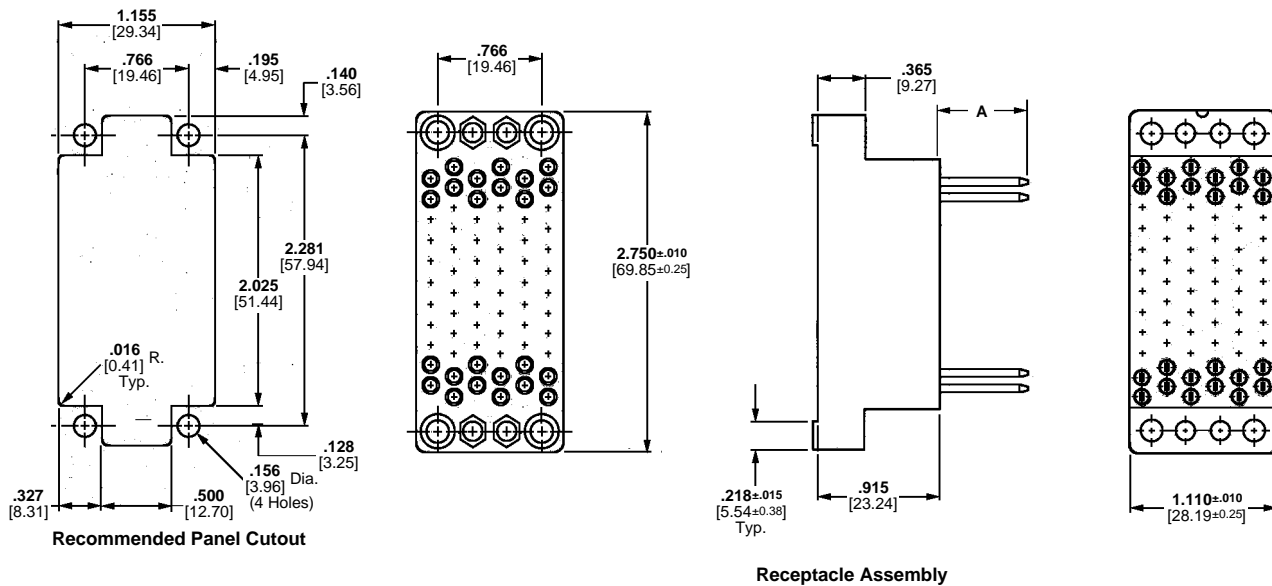

104 Position

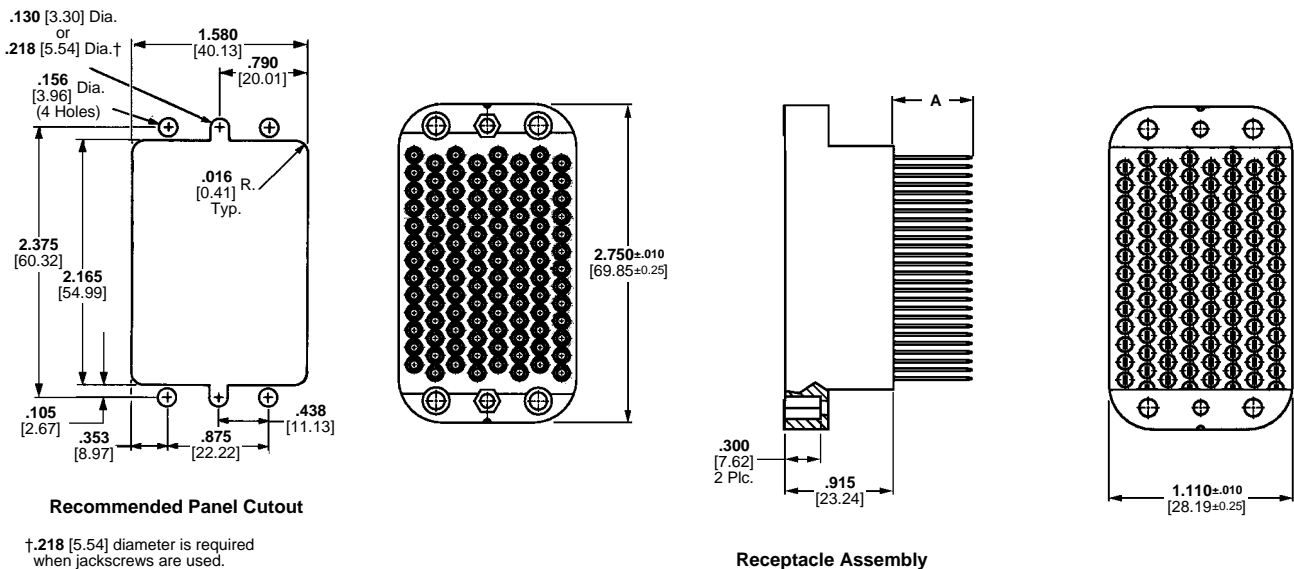

†.218 [5.54] diameter is required when jackscrews are used.

Receptacle Assemblies

No. of Pos.	Termination Method	Post Configuration	A Dimension	Contact Finish	Receptacle Assembly Part No.
75	Wrap-Type	.025 x .025 0.64 x 0.64	.659 16.74	Sel. Gold/Nickel ¹	205515-1
104	Wrap-Type	.025 x .025 0.64 x 0.64	.659 16.74	Sel. Gold/Nickel ¹	205359-1

¹Gold flash over .000050 [0.00127] nickel on entire contact, with .000030 [0.00076] gold to a distance of .200 [5.08] from mating end. Posts are plated tin-lead over copper.

Notes: 1. Posted connectors listed above have black phenolic housings.

2. Replacement contacts are shown on page 32.

3. These posted connectors mate with standard connector housings shown on page 49.

Posted Connectors with Center Fastener

**104 CF Position
(with Center Fastener)**

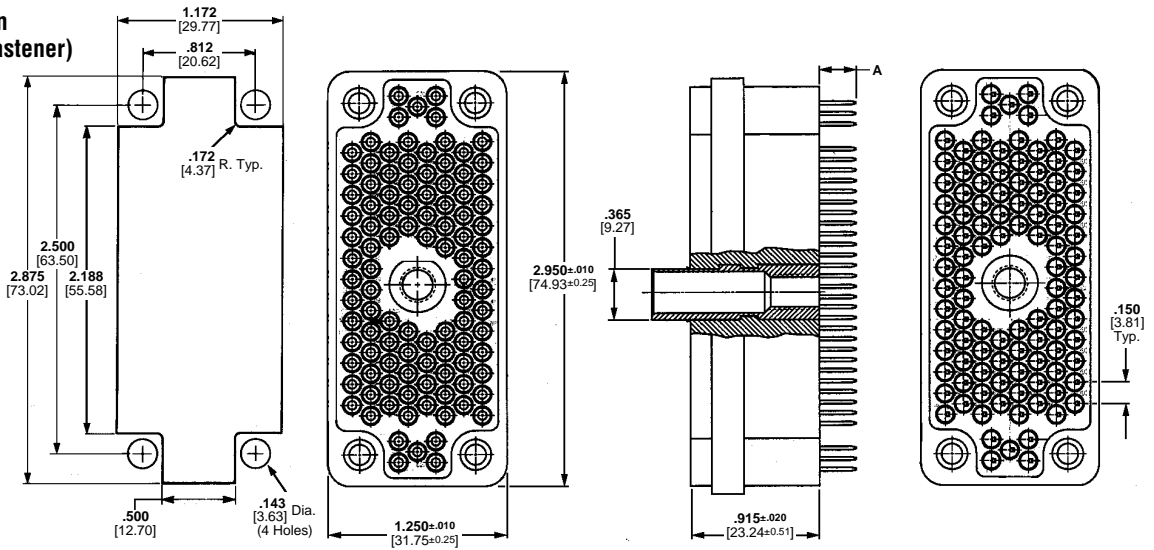

Recommended Panel Cutout

Receptacle Assembly (With Posted Socket Contacts)

**104 CF Position
(with Center Insert)**

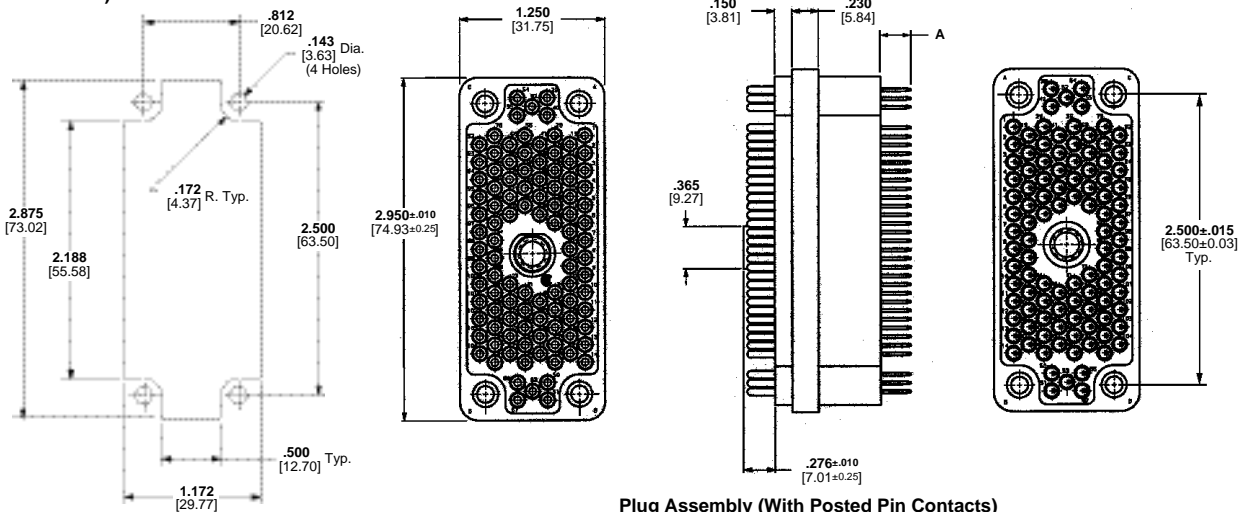

Plug Assembly (With Posted Pin Contacts)

**160 CF Position
(with Jackscrew Socket)**

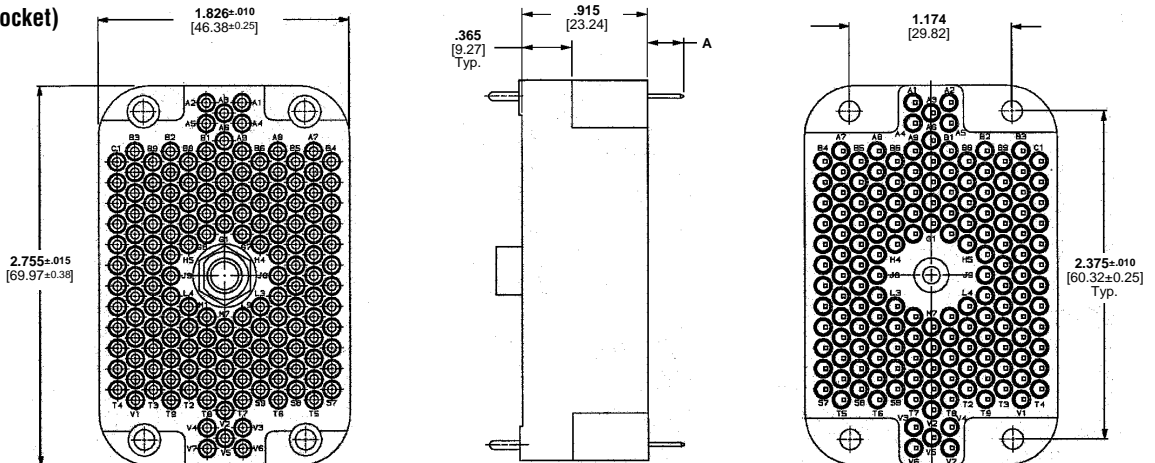

Receptacle Assembly (With Posted Pin Contacts)

Posted Connectors

Posted Connectors, with Center Fastener (Continued)

Receptacle Assembly

No. of Pos.	Termination Method	Post Configuration	Housing Material (Color)	A Dimension	Contact Finish	Receptacle Assembly Part No.	Mating Plug Assembly Part No.
104 CF	Wrap-Type	.025 x .025 0.64 x 0.64	Phenolic (Black)	.659 16.74	Sel. Gold/Nickel ¹	205720-2	Page 50
			Diallyl Phthalate (Blue)	.261 6.63	Sel. Gold/Nickel ¹	205720-1	
160 CF	Wrap-Type	.025 x .025 0.64 x 0.64	Diallyl Phthalate (Blue)	.261 6.63	Sel. Gold/Nickel ²	—	213763-1
			Diallyl Phthalate (Blue)	.261 6.63	Sel. Gold/Nickel ²	213521-1	202799 (Page 51)

¹Gold flash over .000050 [0.00127] nickel on entire contact, with .000030 [0.00076] gold to a distance of .200 [5.08] from mating end. Posts are plated tin-lead over copper.

²Gold flash over .000050 [0.00127] nickel on entire contact, with .000030 [0.00076] gold to a distance of .250 [6.53] from mating end. Posts are plated tin-lead over copper.

Extraction Tool Part No. 305183.

Note: Replacement contacts (Type III+ posted) are shown on page 32.

Posted Connectors, .200 [5.08] Grid

15 Position

Related Product Data

Part Number—See chart on Page 60

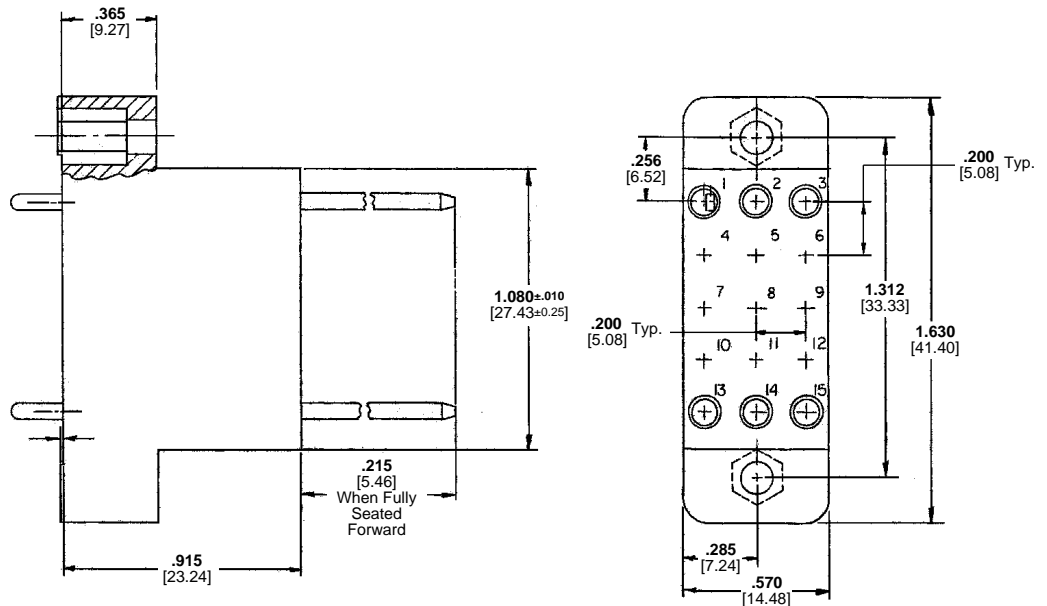

Plug Assembly (With Posted Pin Contacts)

Posted Connectors

Posted Connectors, .200 [5.08] Grid (Continued)

36 Position

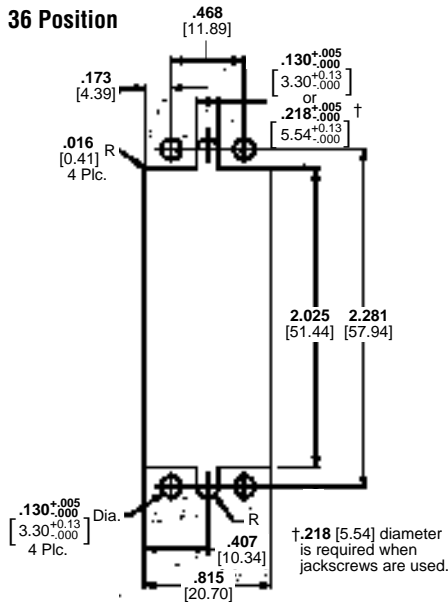

Recommended Panel Cutout

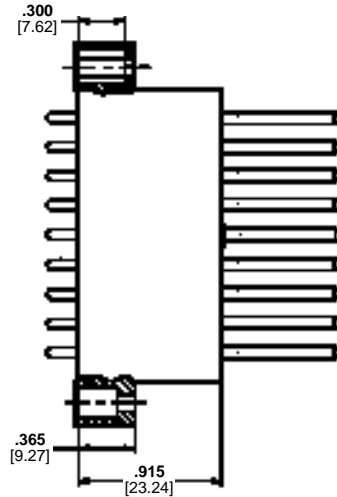

Plug Assembly (With Posted Pin Contacts)

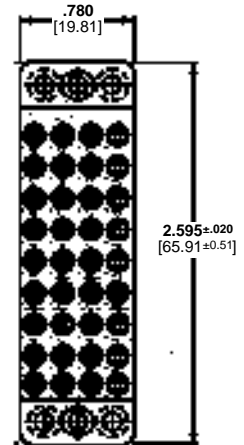

50 Position

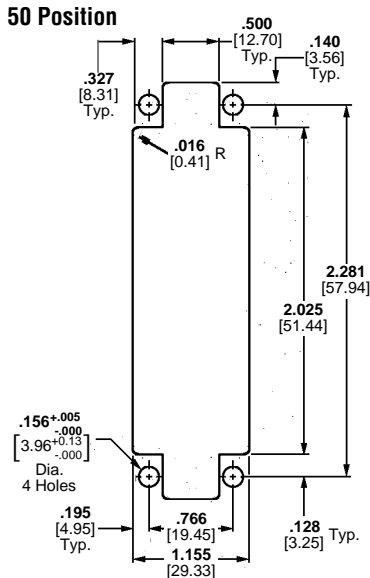

Recommended Panel Cutout

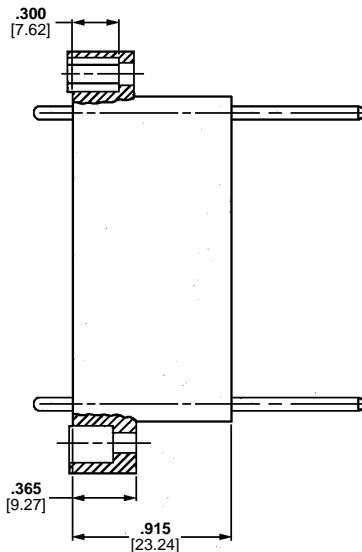

Plug Assembly (With Posted Pin Contacts)

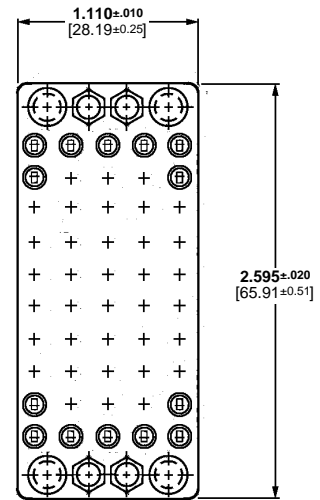

Posted Connectors

Plug Assemblies

No. of Pos.	Termination Method	Post Configuration	Post Length†	Contact Finish	Plug Assembly Part Number	Mates with Receptacle Assembly Part Number
15	Wrap-Type	.025 x .025 0.64 x 0.64	.215 5.46	Sel. Gold/Nickel ¹	205628-3	205606
36	TERMI-POINT	.031 x .062 0.79 x 1.57	.810 20.57	Sel. Gold/Nickel ¹	205629-1▲	▲
50	Clip	.031 x .062 0.79 x 1.57	.810 20.57	Sel. Gold/Nickel ¹	205630-1△△	△△

¹Gold flash over .000050 [0.00127] nickel on entire contact with .000030 [0.00076] gold to a distance of .200 [5.08] from mating end. Posts are plated tin-lead over copper.

†Post length will accommodate up to 3 terminations.

Extraction Tool—Part No. 305183.

Refer to page 32 for contact specifications (Type III+, Size 16).

▲ Mating receptacle block using crimp, snap-in contacts for 36-Position Plug Assembly, order **Part No. 203956-2.**

△△ Mating receptacle block using crimp, snap-in contacts for 50-Position Plug Assembly, order **Part No. 203622-2.**

Refer to the appropriate column of Application Chart for Hardware Selection Page 10 through Page 25.

Note: 36 position connector uses standard 50 position hardware. 50 position connector uses standard 75 position hardware.

Material and Finish

Housing—Phenolic per MIL-M-14, Type CFG; color, black

Contacts—Brass per MIL-C-50; selective .000030 [0.00076] gold over .000050 [0.00127] nickel plated (gold plating per MIL-G-45204, nickel plating per QQ-N-290)

Dimensions are shown for reference purposes only.

Dimensions are in inches and millimeters unless otherwise specified. Values in brackets are metric equivalents.

Specifications subject to change.

Technical Support Center
1-800-522-6752
www.tycoelectronics.com

Special Application Connectors

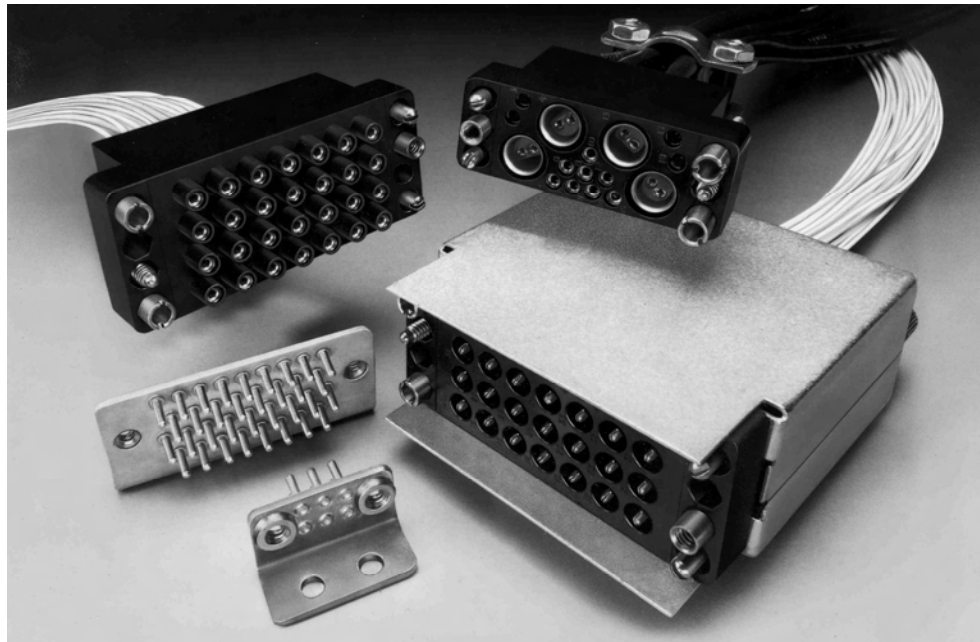

Special Application Connectors are available in the following configurations:

- V.35
- Shallow Block
- High Current
- Mixed
- High Voltage
- RFI/EMI Shielded
- Grounding Blocks

V.35 Connector

The 34 position V.35 Connector is fully assembled and ready for placement on a printed circuit board. They are also available in kit form for cable assembly. These AMP V.35 connectors meet the requirements of 408-2593 for CCITT V.35 interfacing.

High current connectors are designed for applications requiring up to 25 amperes of current. They are available in 12-position male and female housings which have rectangular contact cavities for accepting Type XII contacts.

Mixed connectors are designed for applications that require intermixing signal, power and/or coaxial circuits in the same connector

housing. Housings are available in 15-, 16-, 29 CF (center fastener) and 42-position sizes and, depending upon the specific configuration, will accept Multimate contacts, Type I and Miniature, Standard and Twin Standard COAXICON contacts. The rectangular contact cavities accept Type XII contacts.



High voltage connectors are designed for high voltage applications using Multimate contacts. The cavity center-line spacings and the silo construction of the contact cavities increase the current creepage path for higher voltage ratings. Housing sizes include 20 and 28 positions.

RFI/EMI shielding kits provide shielding capabilities against radio frequency and electromagnetic interferences. Special 104-position housings accept Multimate contacts and are especially designed for use with shielding hardware. These shielding kits cannot be used with the standard 104-position connector housings.

Grounding blocks are ideally suited for aircraft applications, where shielded cable is to be grounded to an airframe. The ground wires of shielded cables are pig-tailed off with ferrules and are crimped to Size 16 socket contacts. The contacts are loaded into a standard 14- or 34-position connector housing. This connector then can be mated to the grounding block which is fastened to the aircraft frame. Grounding blocks have Size 16 screw-machined pin contacts which are staked, riveted and soldered into the L-shaped metal bracket. The bracket has fixed jackscrew receptacles that will accept the special turnable jackscrews fastened to the mating socket connector half.

M Series V.35 Special Application Connectors

Product Facts

- Meets requirements of 408-2593 for CCITT V.35 interface
- Pcb connectors fully assembled, right-angle and vertical mount
- Mounting bracket secures pcb connector to board
- Pcb connectors preloaded with Size 16 contacts
- Right-angle connector features true position location wafer
- Intermateable with comparable M Series connectors
- Cable connector kits available with 1-piece stamped and formed shield or new, more durable die cast 2-piece shield
- Cable connectors accept Size 16, Type III+ strip form or loose piece contacts
- Housings made of UL 94V-0 rated flame retardant material
- Recognized under the Component Program of the Underwriters Laboratories Inc. for 250 volts, File No. E28476 
- Certified by Canadian Standards Association, File No. LR7189 

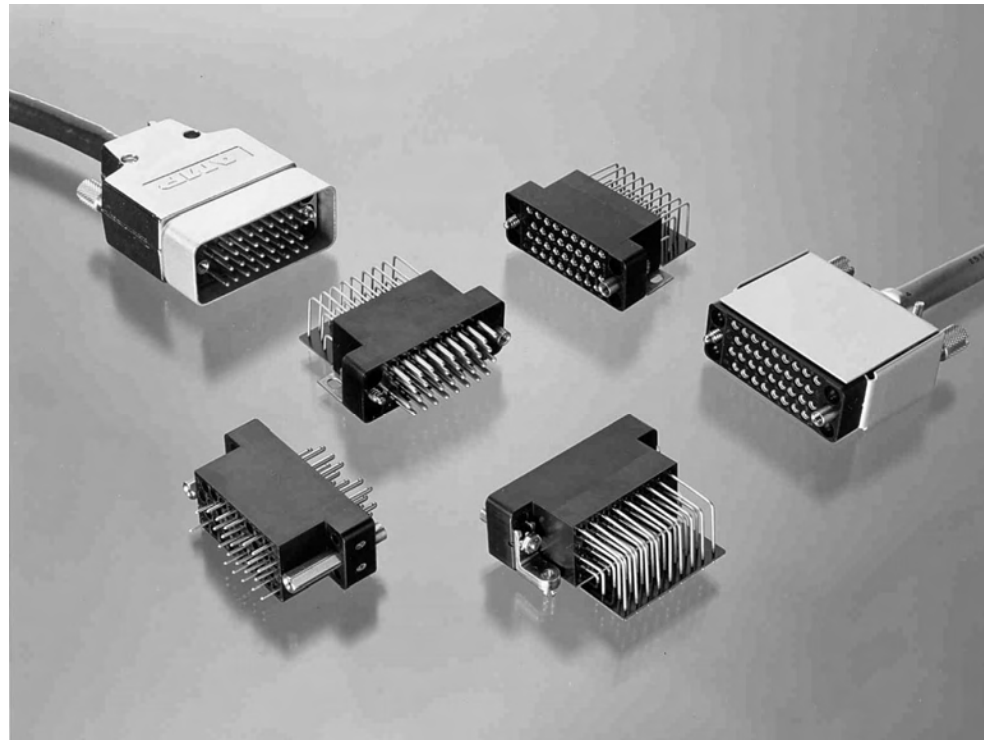

The 34-position V.35 includes both printed circuit board mount and cable mount configurations.

The pcb connectors are fully assembled and ready for placement on printed circuit boards. Available in vertical or right-angle mount versions, they offer dependable, convenient assembly in high-speed data transmission applications. Connectors are preloaded with economical, dependable Size 16 precision stamped and formed contacts. Contact posts feature a chamfered lead-in that eases assembly to the pc boards. A mounting bracket for securing the connector to the pc board is standard equipment. Right-angle pcb connectors feature true position, location wafers that provide for the exact location of each post. Both the right-angle and vertical mount pcb connectors are fully mateable with comparable M Series connectors.

Cable connector assemblies are offered in kit form. Each kit contains: a 34-position housing; one-piece or two-piece shield; two, one-piece turnable jackscrews; strain relief clamp; and necessary mounting screws. Shields are offered in an economical one-piece stamped and formed version or a more durable two-piece die cast version. A choice of die cast zinc, nickel plated or stainless steel turnable jackscrews are available. Cable connectors accept Size 16, Type III+ pin and socket contacts. (Contacts sold separately, see page 31.)

AMP M Series V.35 Special Application Connectors meet the requirements of ISO 2593 for CCITT V.35 interface.

Technical Documents

- Product Specifications—**
108-10001 M Series Connectors
108-10042 Type III+ Contacts
- Application Specification—**
114-10004 Type III+ Contacts
- Instruction Sheet—**
408-9731 M Series V.35 Cable Connector Kits

M Series V.35 Special Application Connectors (Continued)**Material Specifications****Contacts**

The material composition and construction of AMP Type III+ contacts encompasses varying price ranges and performance characteristics. Specific materials and available plating thicknesses of each contact are provided.

Housings

M Series V.35 connector housings are made of general purpose phenolic (black) or polyester (black). Phenolic housings are molded of material per MIL-M-14, Type CFG. The performance characteristics of this material makes the connector an excellent choice in applications where exceptional resistance to acids, alkalies, or solvents is not a prime factor.

Hardware

A variety of materials such as plated steel, stainless steel, zinc (nickel plated) and aluminum are used in the manufacture of M Series V.35 connector hardware. This provides for the proper operation and durability of each hardware component, while offering a choice of economies to satisfy particular application requirements.

Current Carrying Capabilities

The total current capacity of each contact in any given M Series connector is dependent upon the heat rise resulting from the combination of electrical loads of all contacts in the connector arrangement and the maximum ambient temperature in which the connector will be operating. Caution must be taken to insure that this combination of conditions does not cause the internal temperature of the connector to exceed the maximum operating temperature of the housing material. Several variables which must be considered when determining this maximum current capability for your application are:

- a) Wire Size - Larger wire will carry more current since it has less internal resistance to current flow and generates less heat. The wire also conducts heat away from the connector.
- b) Connector Size - In general, with more circuits in a connector, less current per contact can be carried.
- c) Current Load Distribution - Spreading those lines with greater current loads throughout the connector, particularly around the outer perimeter, will enhance heat dissipation.
- d) Ambient Temperature - With higher ambient temperature, less current can be carried.

Performance Data

Temperature Rating—Phenolic Housings, -55°C to +150°C

Polyester Housings— -55°C to +130°C

Flammability Rating—Phenolic Material, UL 94V-0

Dielectric Withstanding Voltage (at sea level)

Type III+ Contacts, 900 VAC, RMS

Durability (Mating/Unmating)— Contacts, Gold plated— 500 cycles; Contacts, Bright tin-lead plated— 50 cycles

Note: For detailed information on the above performance data and further information on other performance data such as Insulation Resistance, Thermal Shock, Moisture Resistance, Vibration and Physical Shock, request AMP Product Specification No. 108-10001.

M Series V.35 Printed Circuit Board Connectors

Right-Angle Receptacle Assembly



Material and Finish

Housing—Flame retardant phenolic or polyester, black

Contacts—Brass, plated:
a) .000030 [0.00076] gold min. in mating area, .000050 [0.00127] nickel min. underplating overall

Contact Spring—Stainless steel

Contact Post—Brass, tin-lead plated

Mounting Bracket—Brass, tin-nickel plated or zinc, nickel plated

Boardlocks—Copper alloy, tin-lead plated

Location Wafer—Phenolic

Nuts and Lockwashers—Steel, zinc plated

Jackscrews—Stainless steel

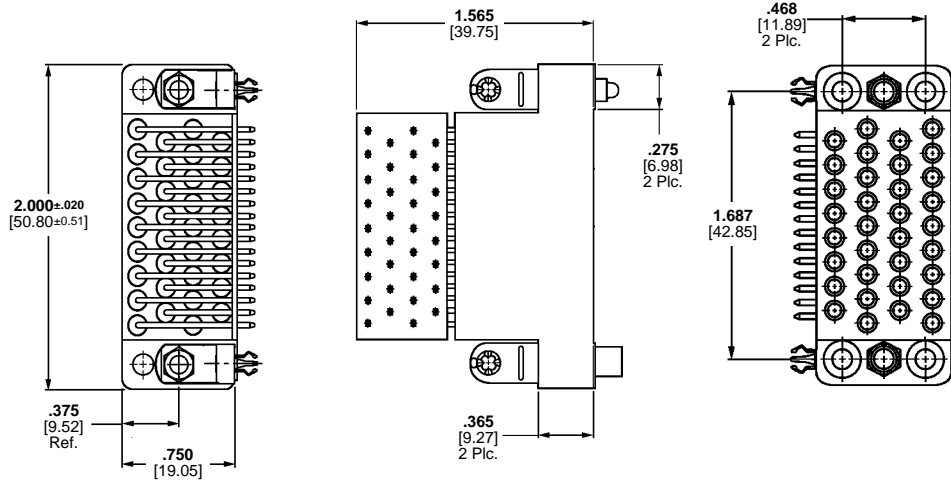

(For Recommended PC Board Hole Pattern see page 65)

No. of Pos.	Mounting Bracket	PCB Dimensions		Boardlocks	Housing Material	Select Load Pattern	Part Number
		A	B				
34	Brass, Tin-Nickel Plated	.555	*	No	Phenolic	Fully Loaded	212810-2
14		14.10	*	No	Phenolic	B, C, D, E, F, H, P, R, S, T, V, X, Y, AA	1-212810-1
27		14.10	*	No	Phenolic	A, B, C, D, E, F, H, J, P, R, S, T, U, V, W, X, Y, AA, BB, CC, DD, FF, HH, JJ, KK, LL, NN	1-212810-5
34	Zinc, Nickel Plated	.572	.347	Yes	Phenolic	Fully Loaded	213574-2
17		14.53	8.81	Yes	Phenolic	A, B, C, D, E, F, H, P, R, S, T, U, V, W, X, Y, AA	213574-4
23		.572	.347	Yes	Phenolic	A, B, C, D, E, F, H, J, K, L, N, P, R, S, T, U, V, W, X, Y, AA, BB, NN	213574-6
22		14.53	8.81	Yes	Phenolic	A, B, C, D, E, F, H, K, L, N, P, R, S, T, U, V, W, X, Y, AA, BB, NN	213574-7
22		.555	.330	Yes	Phenolic	A, B, C, D, E, F, H, J, L, N, P, R, S, T, U, V, W, X, Y, AA, HH, NN	213574-8
		14.10	8.38				

No. of Pos.	Mounting Bracket	PCB Dimensions		Boardlocks	Housing Material	Select Load Pattern	Part Number
		A	B				
34	Brass, Tin-Nickel Plated	.555	*	No	Polyester	Fully Loaded	213806-1
34	None	—	*	No	Polyester	Fully Loaded	213806-4
19	Brass, Tin-Nickel Plated	.555	*	No	Polyester	A, B, C, D, E, F, H, J, L, P, R, S, T, U, V, W, X, Y, AA Hardware Supplied Unassembled	213806-2
18	None	—	*	—	Polyester	A, B, C, D, E, F, H, K, P, R, S, T, U, V, W, X, Y, AA No Hardware Supplied	213806-3
34	Zinc, Nickel Plated	.572	.347	Yes	Polyester	Fully Loaded	213807-1
23	Zinc, Nickel Plated	.572	.347	Yes	Polyester	A, B, C, D, E, F, H, J, K, L, N, P, R, S, T, U, V, W, X, Y, AA, BB, NN	213807-2
23	Zinc, Nickel Plated	.572	.347	Yes	Polyester	A, B, C, D, E, F, H, J, L, N, P, R, S, T, U, V, W, X, Y, AA, HH, KK, NN	213807-3
17	Zinc, Nickel Plated	.572	.347	Yes	Polyester	A, B, C, D, E, F, H, P, R, S, T, U, V, W, X, Y, AA	213807-4
		14.53	8.81				

*The mounting bracket has an elongated slot for a 4-40 screw that will accommodate a .330 [8.38] or .347 [8.81] footprint.

Note: Other select loaded configurations can be made available; consult Tyco Electronics Corporation.

M Series V.35 Printed Circuit Board Connectors (Continued)

Right-Angle Plug Assembly



Material and Finish

Housing—Flame retardant phenolic or polyester, black

Contacts—Brass, plated:
a) .000030 [0.00076] gold min. in mating area, .000050 [0.00127] nickel min. underplating overall

Contact Spring—Stainless steel

Contact Post—Brass, tin-lead plated

Mounting Bracket—Brass, tin-nickel plated or zinc, nickel plated

Boardlocks—Copper alloy, tin-lead plated

Location Wafer—Phenolic

Nuts and Lockwashers—Steel, zinc plated

Jackscrews—Stainless steel

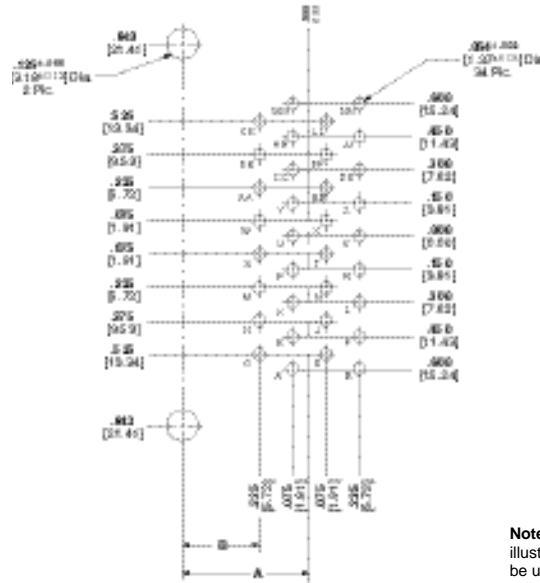
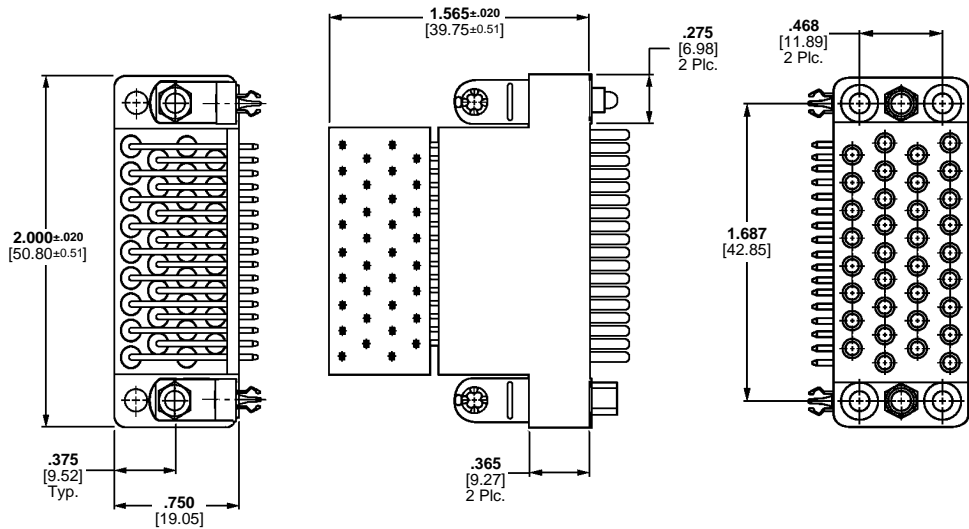

Recommended PC Board Hole Pattern
(All dimensions typical)

Note: Pc board layouts and connector dimensions illustrated above serve as a guide only; they are not to be used for actual design or construction of customer equipment. Consult AMP customer drawings for latest detailed pc board layout and connector dimension requirements.

No. of Pos.	Mounting Bracket	Dimensions		Boardlocks	Housing Material	Select Load Pattern	Part Number
		A	B				
34	Brass, Tin Nickel Plated	.555 14.10	*	No	Phenolic	Fully Loaded	213289-1
34	Zinc, Nickel Plated	.572 14.53	.347 8.81	Yes	Phenolic	Fully Loaded	213513-2

*The mounting bracket has an elongated slot for a 4-40 screw that will accommodate a .330 [8.38] or .347 [8.81] footprint.

Note: Other select loaded configurations can be made available; consult Tyco Electronics Corporation.

No. of Pos.	Mounting Bracket	Dimensions		Boardlocks	Housing Material	Select Load Pattern	Part Number
		A	B				
34	Zinc, Nickel Plated	.572 14.53	.347 8.81	Yes	Polyester	Fully Loaded	213808-1
18	—	No Hardware Supplied			Polyester	A, B, C, D, E, F, H, K, P, R, S, T, U, V, W, X, Y, AA	213808-2

Note: Other select loaded configurations can be made available; consult Tyco Electronics Corporation.

M Series V.35 Printed Circuit Board Connectors (Continued)

Vertical Receptacle Assembly



Material and Finish

Housing—Flame retardant phenolic or polyester, black

Contacts—Brass, plated:
a) .000030 [0.00076] gold min. in mating area, .000050 [0.00127] nickel min. underplating overall

Contact Spring—Stainless steel

Contact Post—Brass, tin-lead plated

Nuts and Lockwashers—Steel, zinc plated

Spacers—Stainless steel

Jackscrews—Stainless steel

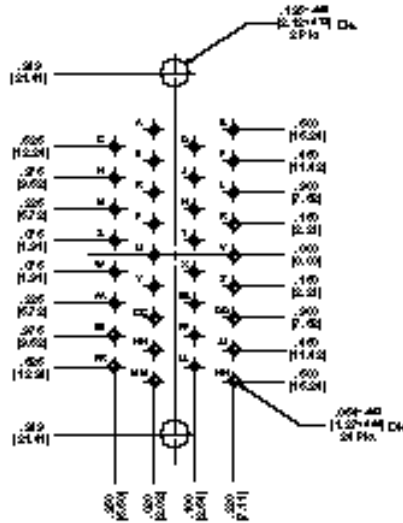
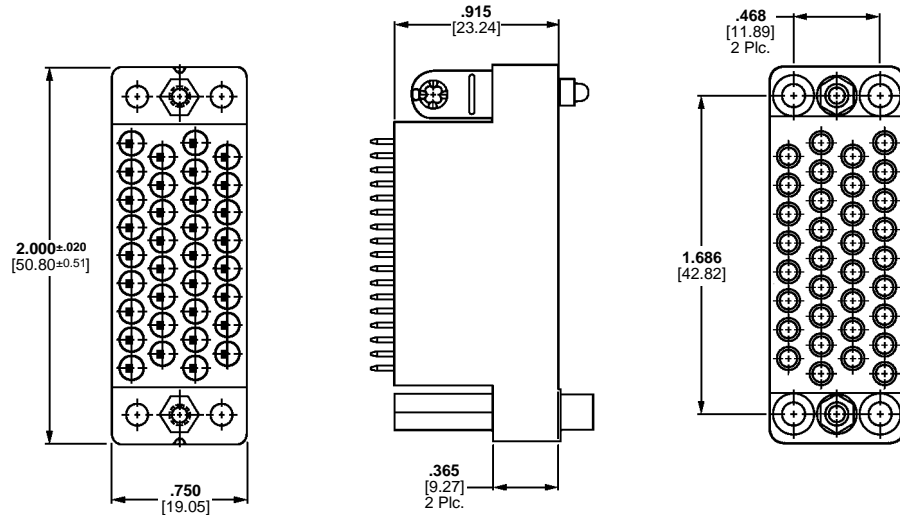

Note: Pc board layouts and connector dimensions illustrated above serve as a guide only; they are not to be used for actual design or construction of customer equipment. Consult AMP customer drawings for latest detailed pc board layout and connector dimension requirements.

No. of Pos.	Mounting Hardware	Housing Material	Select Load Pattern	Part Number
34	None	Phenolic	Fully Loaded	213473-1
	Spacers	Phenolic	Fully Loaded	213524-1
		Polyester	Fully Loaded	213809-1
13	Nuts & Lockwashers	Phenolic	B, C, D, E, F, P, R, S, T, V, X, Y, AA	213524-2

Note: Other select loaded configurations can be made available; consult Tyco Electronics Corporation.

M Series V.35 Printed Circuit Board Connectors (Continued)

Vertical Plug Assembly



Material and Finish

Housing—Flame retardant phenolic, black

Contacts—Brass, plated:
a) .000030 [0.00076] gold min. in mating area, .000050 [0.00127] nickel min. underplating overall

Contact Spring—Stainless steel

Contact Post—Brass, tin-lead plated

Nuts and Lockwashers—Steel, zinc plated

Spacers—Stainless steel

Jackscrews—Stainless steel

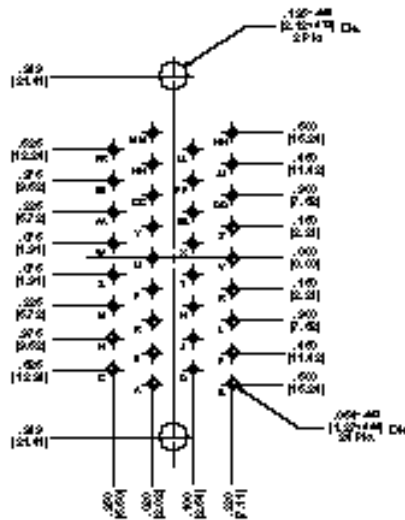
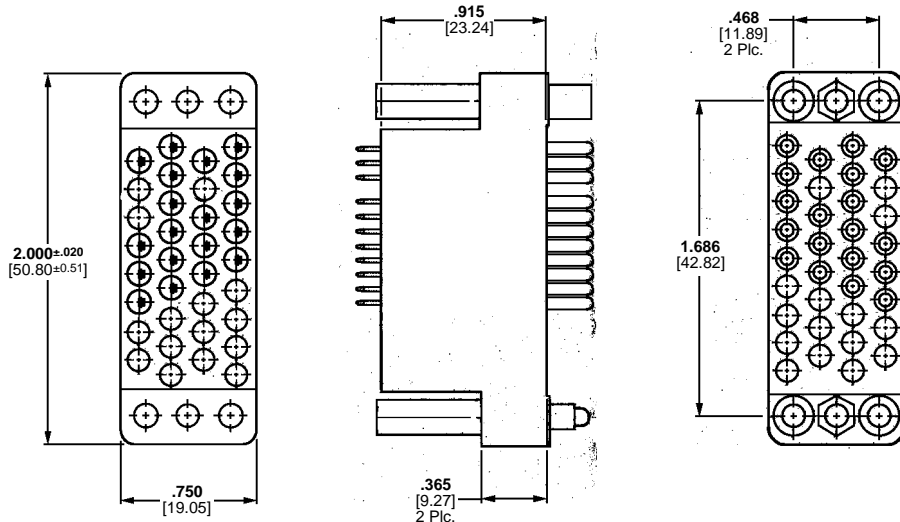

Recommended PC Board Hole Pattern
(All dimensions typical)

Note: Pc board layouts and connector dimensions illustrated above serve as a guide only; they are not to be used for actual design or construction of customer equipment. Consult Tyco Electronics customer drawings for latest detailed pc board layout and connector dimension requirements.

No. of Pos.	Mounting Hardware	Select Load Pattern	Part Number
19	Spacers*	A, B, C, D, E, F, K, L, N, P, R, S, T, U, V, W, X, Y, AA	213550-1
17	Nuts & Lockwashers	B, C, D, E, F, H, J, P, R, S, T, U, V, W, X, Y, AA	213550-2

*Jackscrews and spacers are provided unassembled.

Note: Other select loaded configurations can be made available, consult Tyco Electronics Corporation.

M Series V.35 Cable Connectors

Cable Connector Kits, 34 Position, Phenolic



Plug



Receptacle

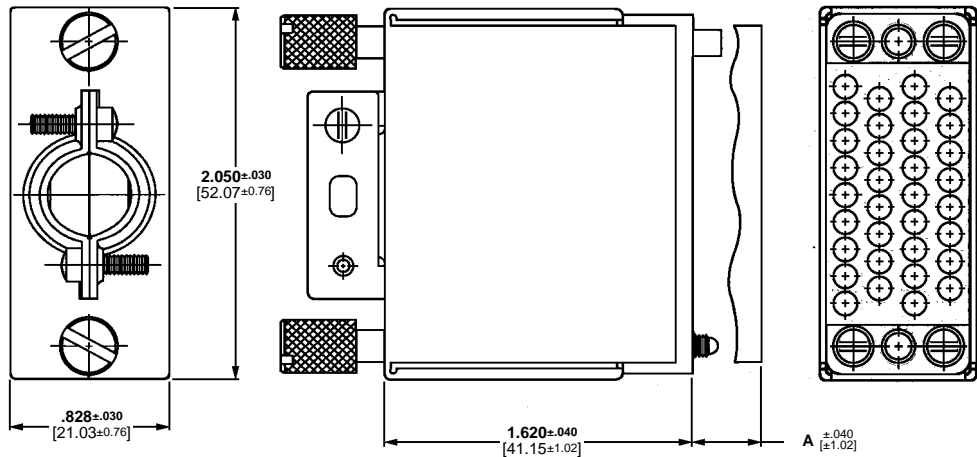

Material and Finish

Housing—Flame retardant phenolic, black

Shield—Anodized aluminum

Screws—Steel, zinc plated

Jackscrews—Stainless steel

Cable Clamp—Steel, nickel plated

Kits include:

- Housing
- One-piece shield
- One-piece turnable jackscrews
- Strain relief clamp
- Mounting screws

Notes:

1. Plug and receptacle connector kits come partially assembled.
2. Plug connector kits are available with long and short shields, (long shield provides pin protection) and two different size cable clamps.
3. Housings are keyed to fix the proper location of the male and female jackscrew as defined by 408-2593.
4. Short shield kits, **Part No. 213753-1** available with all accessories listed above except housing block and jackscrews. Part number for blocks are found on page 47.
5. Pin and socket contacts sold separately. Size 16, Type III+ contacts are listed on page 31.

Shield Size	Cable Dia. Range	Housing Material	Dimension A	Kit Part Numbers	
				Receptacle	Plug
Short	.435-.545 11.05-13.83	Phenolic	1.53 38.86	—	213300-1
Short	.300-.450 7.62-11.43	Phenolic	1.53 38.86	—	213300-2
Long	.435-.545 11.05-13.83	Phenolic	1.97 50.04	—	213300-3
Long	.300-.450 7.62-11.43	Phenolic	1.97 50.04	—	213300-4
Short	.435-.545 11.05-13.83	Phenolic	1.53 38.86	213522-1	—
Short	.300-.450 7.62-11.43	Phenolic	1.53 38.86	213522-2	—
Short	.200-.300 5.08-7.62	Phenolic	1.53 38.86	213522-4	—
Short	.200-.300 5.08-7.62	Phenolic	1.53 38.86	—	213300-7

M Series V.35 Cable Connectors (Continued)

Cable Connector Kits, 34 Position, Polyester (Continued)



Plug



Receptacle

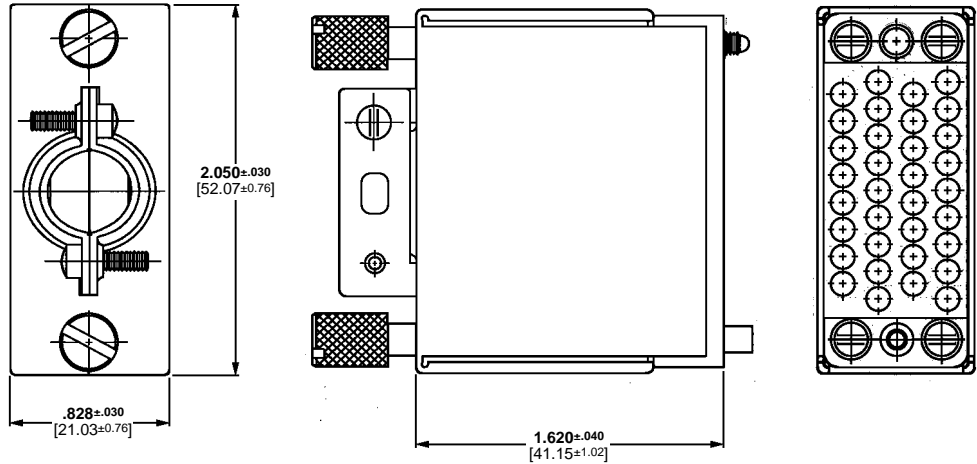

Material and Finish

Housing—Flame retardant polyester, black

Shield—Anodized aluminum

Screws—Steel, zinc plated

Jackscrews—Stainless steel or zinc, nickel plated

Cable Clamp—Steel, nickel plated

Kits include:

- Housing
- One-piece shield
- One-piece turnable jackscrews
- Strain relief clamp
- Mounting screws

Notes:

1. Plug and receptacle connector kits come partially assembled.
2. Two different size cable clamps.
3. Housings are keyed to fix the proper location of the male and female jackscrew as defined by 408-2593.
4. Pin and socket contacts sold separately. Size 16, Type III+ contacts are listed on page 31.

Packaging	Cable Dia. Range	Housing Material	Jackscrew Type	Kit Part Numbers	
				Receptacle	Plug
Bulk	.435-.545 11.05-13.83	Polyester	Stainless Steel	213931-1	—
Individual	.300-.450 7.62-11.43	Polyester	Stainless Steel	213931-2	—
Individual	.435-.545 11.05-13.83	Polyester	Zinc	213931-3	—
Individual	.435-.545 11.05-13.83	*	Zinc	213931-4	—
Individual	.300-.450 7.64-11.43	Polyester	Zinc	213931-5	—
Bulk	.435-.545 11.05-13.83	Polyester	Stainless Steel	—	213932-1
Individual	.300-.450 7.62-11.43	Polyester	Stainless Steel	—	213932-2
Individual	.435-.545 11.05-13.83	Polyester	Zinc	—	213932-3
Individual	.300-.450 7.62-11.43	Polyester	Zinc	—	213932-4
Individual	.300-.450 7.62-11.43	Polyester	Zinc	—	213932-5**

*Housing not included in Kit No. 213931-4

**Long Shield, Assembled Length – 1.620±.040 [41.15±1.20]

M Series V.35 Cable Connectors (Continued)

Cable Connector Kits, 34 Position, Phenolic (Continued)

Material and Finish

Housing—Flame retardant phenolic, black

Shield—Zinc, nickel plated

Screws—Steel, zinc plated

Jackscrews—Stainless steel or zinc, nickel plated

Cable Clamp—Steel, nickel plated

Kits include:

- Housing
- Two-piece shield
- One-piece turnable jackscrews
- Two cable clamp inserts
- Mounting screws

Notes:

1. Plug and receptacle connector kits come partially assembled.
2. Plug connector kits are available with or without pin hoods.
3. Housings are keyed to fix the proper location of the male and female jackscrew as defined by 408-2593.
4. Choice of stainless steel or zinc die cast one-piece jackscrews.
5. Pin and socket contacts sold separately. Size 16, Type III+ contacts are listed on page 31.

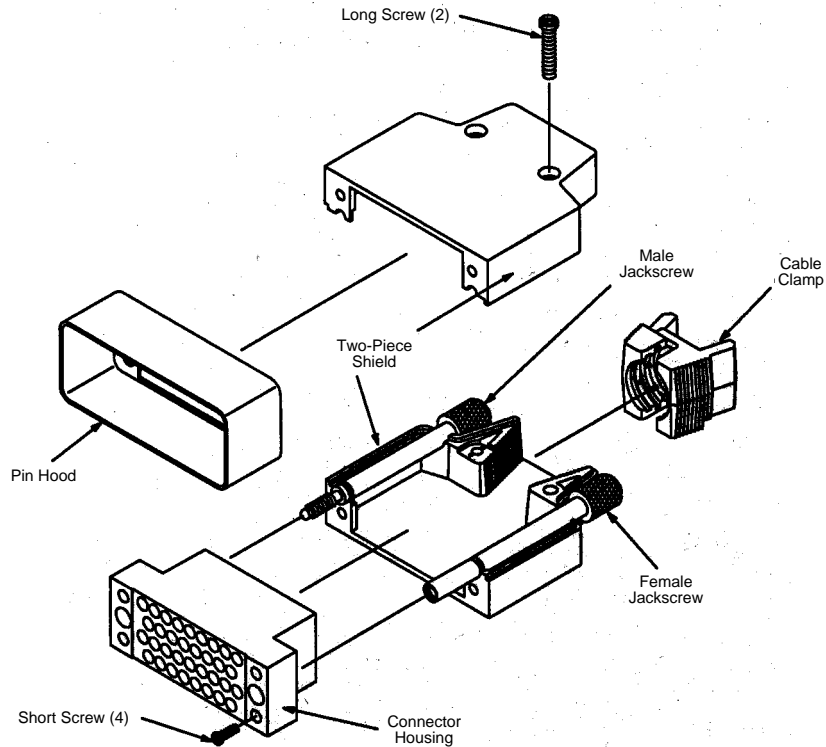

Pin Hood	Cable Dia. Range	Jackscrew Type	Kit Part Numbers	
			Receptacle	Plug
No	.400-.600 10.16-15.24	Zinc	—	213684-1
No	.250-.400 6.35-10.16	Zinc	—	213684-2
Yes	.400-.600 10.16-15.24	Zinc	—	213684-3
Yes	.250-.400 6.35-10.16	Zinc	—	213684-4
No	.400-.600 10.16-15.24	Stainless Steel	—	213684-7
No	.400-.600 10.16-15.24	Zinc	213685-1	—
No	.250-.400 6.35-10.16	Zinc	213685-2	—
No	.400-.600 10.16-15.24	Stainless Steel	213685-3	—
No	.150-.300 3.81-7.62	Zinc	213685-5	—
Yes	.150-.300 3.81-7.62	Zinc	—	213684-9
No	.150-.300 3.81-7.62	Zinc	—	1-213684-0

M Series V.35 Cable Connectors (Continued)

Cable Connector Kits, 34 Position, Polyester (Continued)

Material and Finish

Housing—Flame retardant polyester, black

Shield—Zinc, nickel plated

Screws—Steel, zinc plated

Jackscrows—Zinc, nickel plated

Cable Clamp—Steel, nickel plated

Kits include:

- Housing
- Two-piece shield
- One-piece turnable jackscrows
- Two cable clamp inserts
- Mounting screws

Notes:

1. Plug and receptacle connector kits come partially assembled.
2. Plug connector kits are available with or without pin hoods.
3. Housings are keyed to fix the proper location of the male and female jackscrow as defined by 408-2593.
4. Pin and socket contacts sold separately. Size 16, Type III+ contacts are listed on page 31.

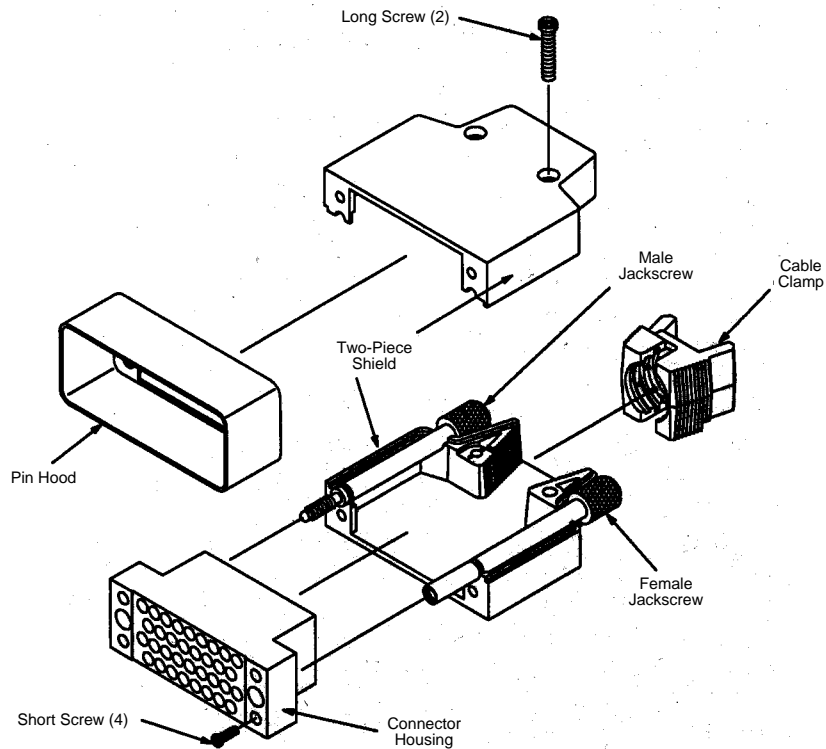

Pin Hood	Cable Dia. Range	Kit Part Numbers	
		Receptacle	Plug
No	.150-.300 3.81-7.62	—	213803-1
No	.250-.400 6.35-10.16	—	213803-2
Yes	.150-.300 3.81-7.62	—	213804-1
Yes	.250-.400 6.35-10.16	—	213804-2
No	.150-.300 3.81-7.62	213805-1	—
No	.250-.400 6.35-10.16	213805-2	—
No	.400-.600 10.16-15.24	—	213803-3
Yes	.400-.600 10.16-15.24	—	213804-3
No	.400-.600 10.16-15.24	213805-3	—

Special Application Connectors

High Current 12 Position UL Voltage Rating: 1800 V

Material and Finish

Housing—Phenolic, 94V-0 rated, black

Contacts must be ordered separately.

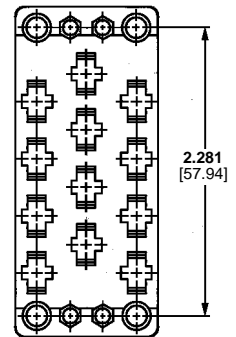
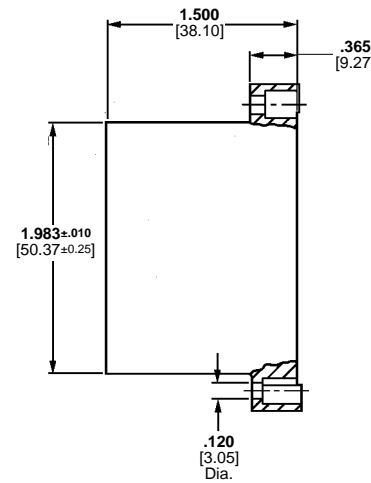
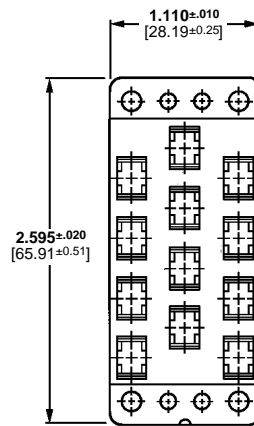
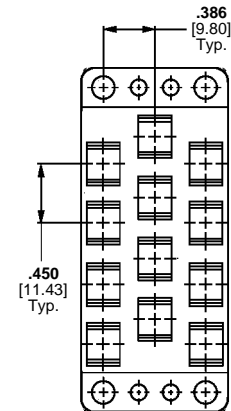
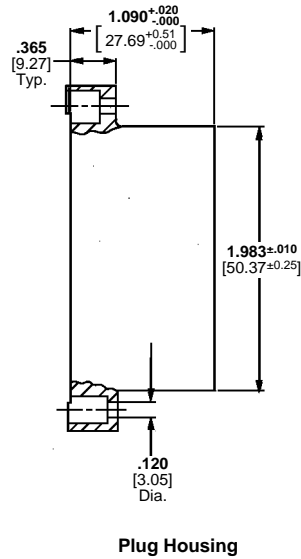
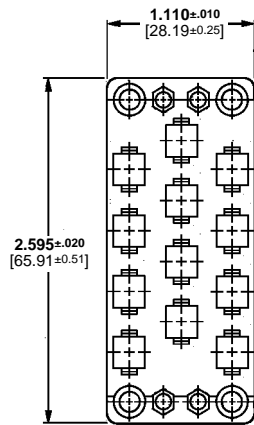
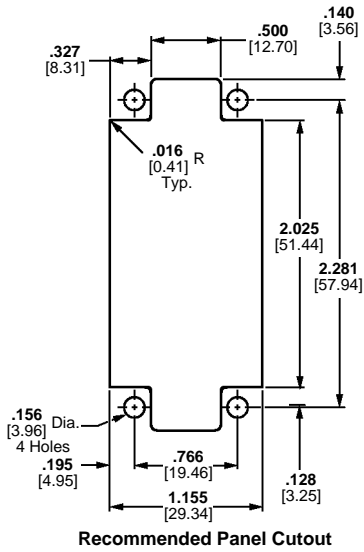

Phenolic Housing Part No.		Contacts Accepted		
Plug	Receptacle	Quantity	Contact Type	Page Ref.
205042-1	205043-1	12	Type XII	38, 39

Note: 12 position connector uses Standard 75 Position Hardware. Refer to appropriate column of Application Charts for Hardware Selection pages 10 through 25.

Special Application Connectors (Continued)

Mixed 29 CF Position (with Center Fastener)

Material and Finish

Housing—Phenolic, 94V-0 rated, black

Contacts must be ordered separately.

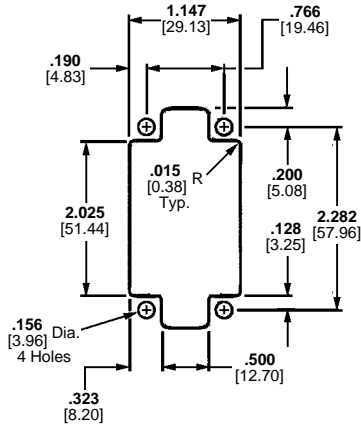

Recommended Panel Cutout

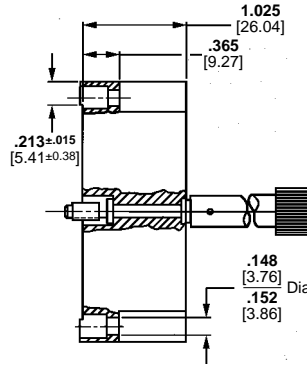
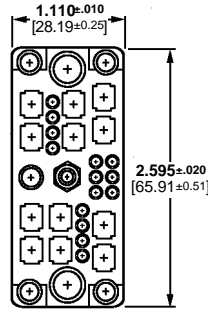

Plug Housing

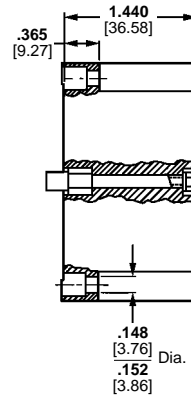
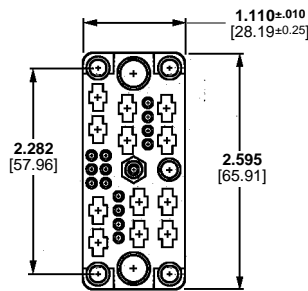
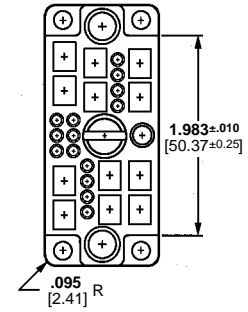

Receptacle Housing

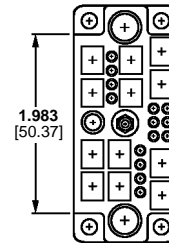

Phenolic Housing Part No.		Contacts Accepted		
Plug	Receptacle	Quantity	Contact Type	Page Ref.
202479-2	202478-2	14*	Type II	30
			Type III+	31-35
			Subminiature COAXICON	40, 41
		12	Type XII	38, 39
		2	Standard COAXICON	—
		1	Type I	36
			Miniature COAXICON	42, 43

*Quantity may be all of the same type, or a combination of those types listed. See Hardware Section for appropriate hardware for this connector. See pages 78-89.

Special Application Connectors (Continued)

Mixed 42 Position

Material and Finish

Housing—Phenolic, black or diallyl phthalate, blue, 94V-0 rated

Contacts must be ordered separately.

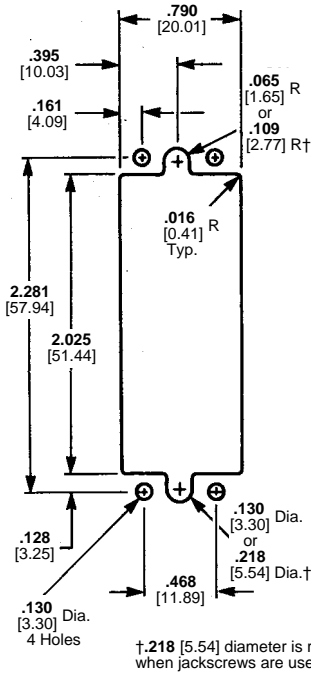

Recommended Panel Cutout

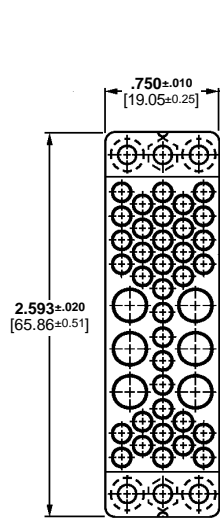

Plug Housing

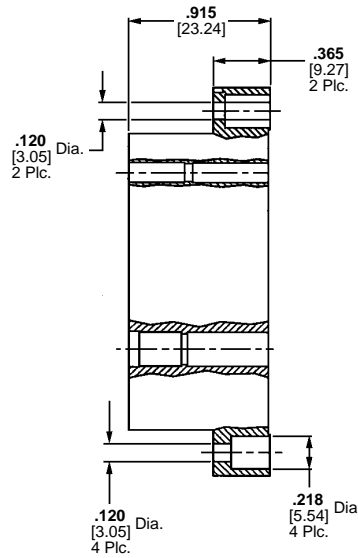

Receptacle Housing

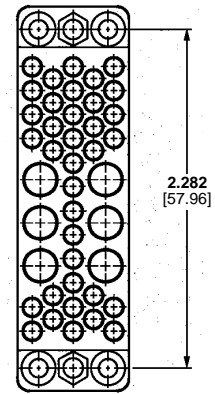

Phenolic Housing Part No.		Diallyl Phthalate Housing Part No.		Contacts Accepted		
Plug	Receptacle	Plug	Receptacle	Quantity	Contact Type	Page Ref.
202515-1	202516-1	202515-3	202516-3	36*	Type II	30
					Type III+	31-35
					Subminiature COAXICON	40, 41
202515-1	202516-1	202515-3	202516-3	6*	Type I	36
					Miniature COAXICON	42, 43

*Quantity may be all of the same type, or a combination of those types listed.

Note: 42 position connector uses Standard 50 Position Hardware. Refer to appropriate column of Application Charts for Hardware Selection pages 10 through 25.

Special Application Connectors (Continued)

**High Voltage 20 Position
UL Voltage Rating:
1800 V**

Material and Finish

Housing—Diallyl phthalate, 94V-0 rated, blue

Contacts must be ordered separately.

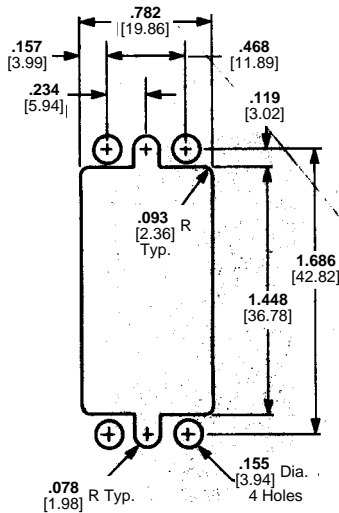

Recommended Panel Cutout

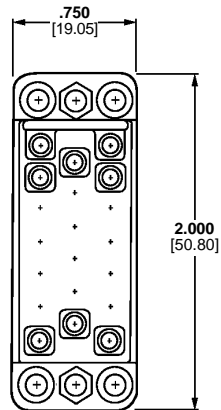

Plug Housing

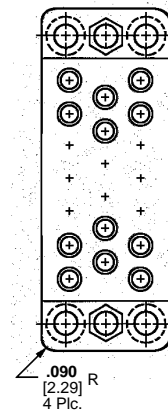
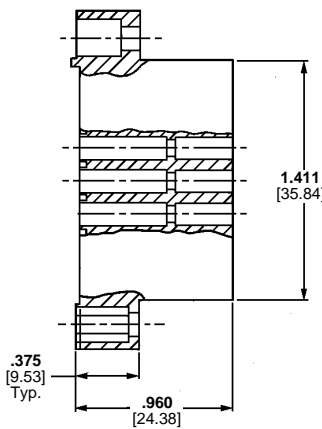

Receptacle Housing

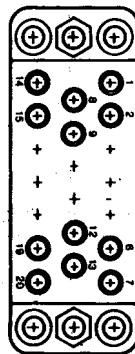

Plug Housing Wiring Side



Receptacle Housing Wiring Side

Diallyl Phthalate Housing Part No.		Contacts Accepted		
Plug	Receptacle	Quantity	Contact Type	Page Ref.
203908-2	203909-2	20*	Type II	30
			Type III+	31-35
			Subminiature COAXICON	40, 41

*Quantity may be all of the same type, or a combination of those types listed.

Note: 20 Position connector uses Standard 34 Position Hardware. Refer to appropriate column of Application Charts for Hardware Selection pages 10 through 25.

Special Application Connectors (Continued)

**High Voltage 28 Position
UL Voltage Rating:
1800 V**

Material and Finish

Housing—Phenolic, 94V-0 rated,
black

Contacts must be ordered
separately.

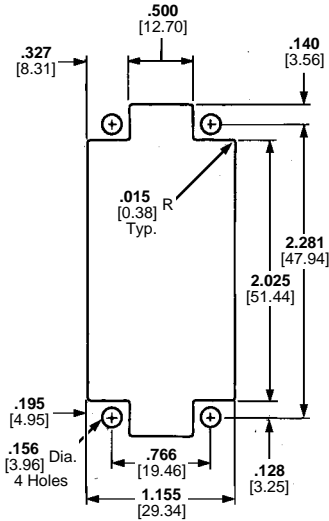

Recommended Panel Cutout

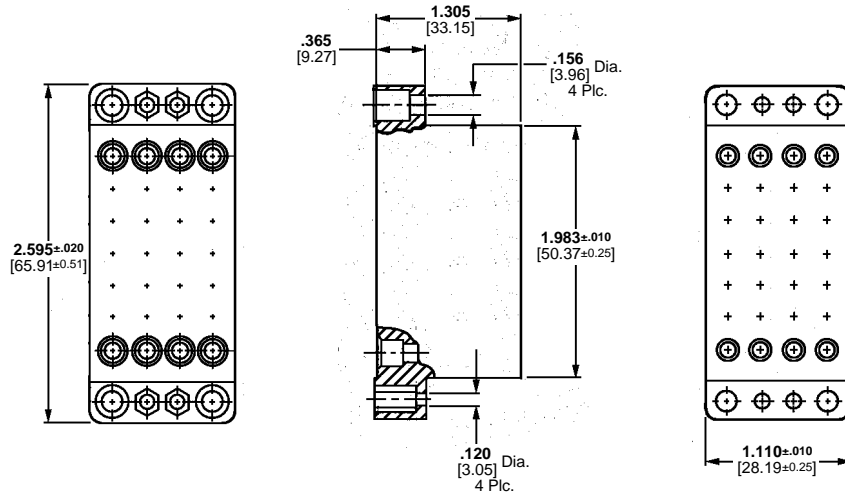

Plug Housing

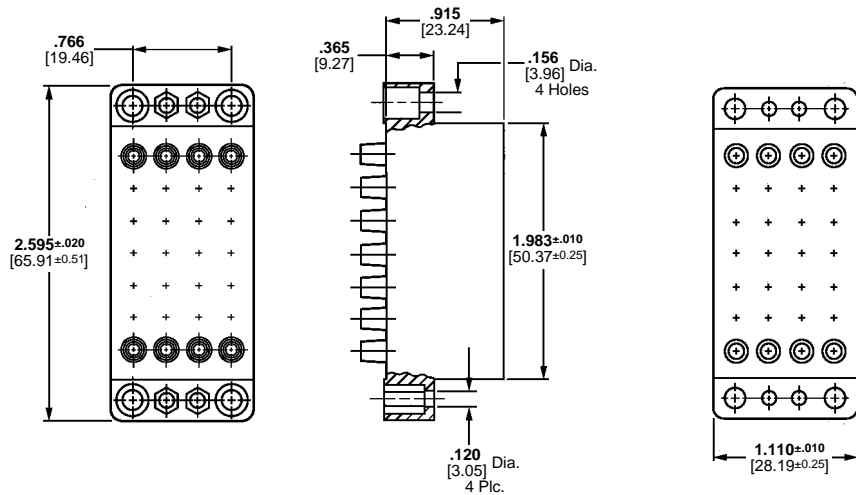

Receptacle Housing

Phenolic Housing Part No.		Contacts Accepted		
Plug	Receptacle	Quantity	Contact Type	Page Ref.
205689-2	205690-2	28*	Type II	30
			Type III+	31-35
			Subminiature COAXICON	40, 41

*Quantity may be all of the same type, or a combination of those types listed.

Note: 28 Position connector uses Standard 75 Position Hardware. Refer to appropriate column of Application Charts for Hardware Selection Pages 10 through 25.

Special Application Connectors (Continued)

Grounding Blocks

Material and Finish

- Plate**—Brass, tin plated
- Clinch Nuts**—Stainless steel
- Pin Contacts**—Phosphor bronze, gold over nickel plated

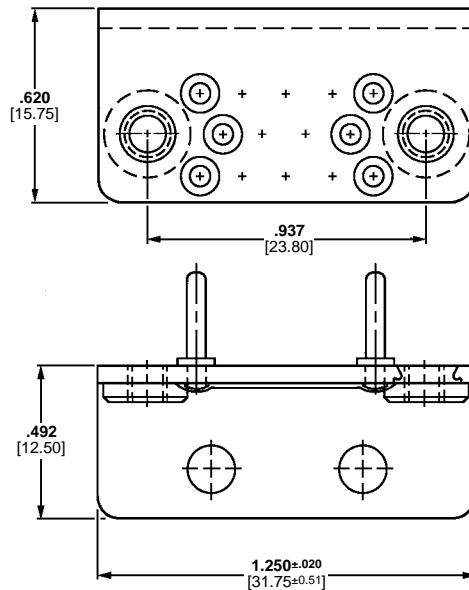

14-Position, Part No. 203540-1*

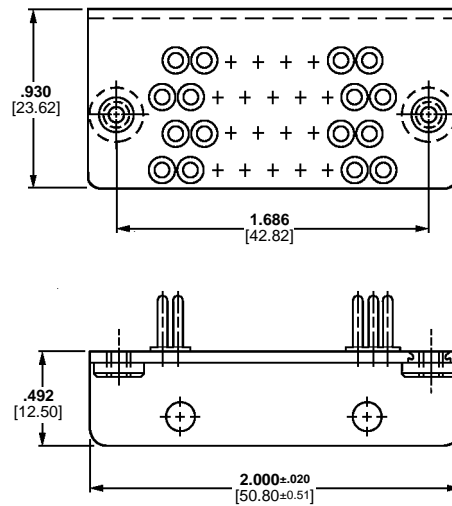

34-Position, Part No. 204814-1*

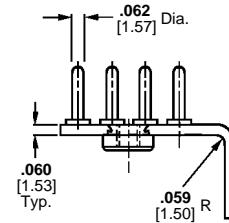
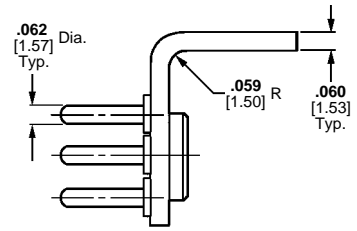

Grounding blocks mate with standard 14 and 34 position receptacle housings.
Note: Use referenced turnable jackscrews on mating housings when mating to grounding blocks.
 *CSA Certification pending.

Fastening Hardware—For use in connector housings to mate with grounding blocks

Jackscrews

Material and Finish

- Jackscrew Body**—Die cast zinc, (clear chromate) conversion coating
- Jackscrew Tip, Roll Pin**—Stainless steel

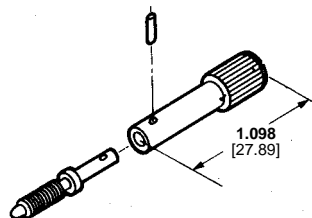

Short Turnable Jackscrew, Male
Part No. 203618-1
(2 Req'd.)

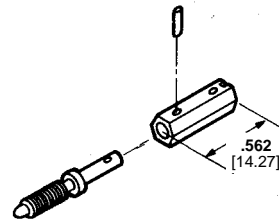

Short-Short Turnable Jackscrew, Male
Part No. 203535-2
(2 Req'd.)

Fastening Hardware

Jackscrews

Material and Finish

Turnable Jackscrew Body—Die cast zinc, chromate conversion coating

Turnable Jackscrew Tip—Stainless steel

Roll Pin—Stainless steel

For Fixed Jackscrews

Lockwasher—Steel

Hex Nut—Steel, zinc plated

Jackscrews are used as an aid in mating and unmating connectors and for holding mated connectors together, mostly larger sizes (34-position and up). They can also be used for polarization.

Turnable jackscrews are free to rotate in a connector housing and are always used opposite mating fixed jackscrews. Where provided, roll pins are used to hold a male or female tip onto the turnable jackscrew body. AMP Assembly Tool No. 91016-2 (shown below) is available for properly assembling the turnable jackscrews on a connector housing.

Fixed jackscrews can be readily assembled to a connector housing with the Nut Driver Tool (also shown below).



AMP Assembly Tool
Part No. 91016-2
(for Roll Pins)



Nut Driver
Part No. 811262-1 (4-40)

Turnable Jackscrews

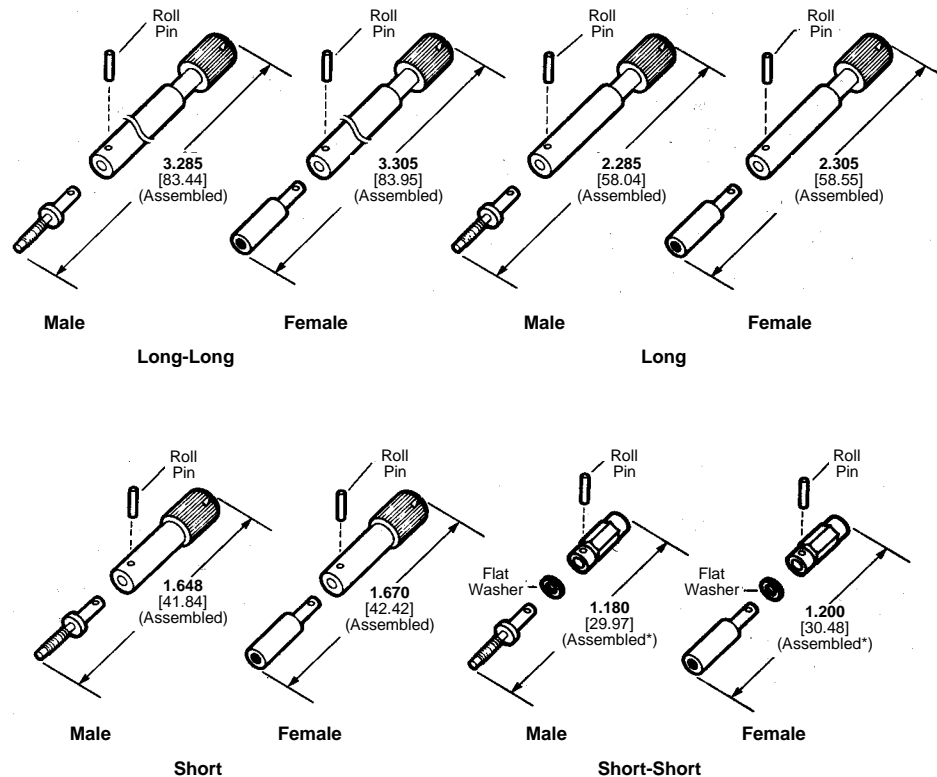

*Assembled dimension includes metal thickness of Pin Hood or Strain Relief Clamp. Remove washer when both Pin Hood and Strain Relief Clamp are used.

Turnable Jackscrews

Style	Jackscrew Part No.		Connectors Used on (No. of Positions)				
	6-32 [M3.5 x 0.6] Double Lead Thread	6-32 [M3.5 x 0.6] Single Lead Thread	Standard	Posted	Special Application		
					High Current	Mixed	High Voltage
Long-Long Male ¹	201911-1	207234-1	50 (90° shield only), 75 and 104	—	12	42	28
Long-Long Female ¹	201910-1	207235-1					
Long Male	200871-1	201413-1	20, 26, 34, 41, and 50	20, 26, 34, 41, and 50	12	15, 16 and 42	20 and 28
Long Female	200867-1	201414-1					
Short Male	200868-1	201087-1	6, 14, 20, 26, 34, 41, 50, 75 and 104	6, 14, 20, 26, 34, 41, 50, 75 and 104	12	15, 16 and 42	20 and 28
Short Female	200870-1	201088-1					
Short-Short Male	201388-1	201827-1	6, 14, 20, 26, 34, 41, 50, 75 and 104	6, 14, 20, 26, 34, 41, 50, 75 and 104	12	15, 16 and 42	20 and 28
Short-Short Female	201389-1	201828-1					

¹Long-Long Turnable Jackscrews are used only with Two-Piece Shields on the connector sizes listed.

Notes: 1. Turnable Jackscrews mate with any Fixed Jackscrew listed below having the same thread size.

2. Special Turnable Jackscrews for use in connector housings to mate with Grounding Blocks are presented on page 77.

3. Single-lead versions are designed to mate with competitive Jackscrews.

Roll pins for turnable jackscrews, Long-Long, Long, Short Part No. 201501-1, Short-Short Part No. 201501-2.

Fastening Hardware (Continued)

Fixed Jackscrews

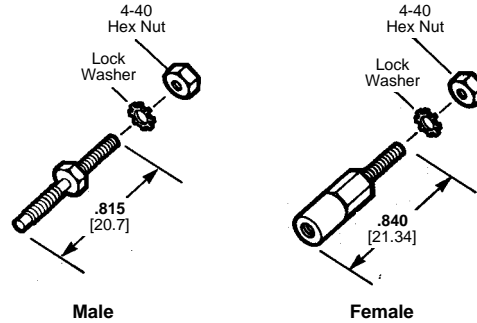

Fixed Jackscrews

Type	Jackscrew Part No.	
	6-32 [M3.5 x 0.6] Double Lead Thread	6-32 [M3.5 x 0.6] Single Lead Thread
Male	200874-1	201092-1
Female	200875-1	201089-1

- Notes:**
1. Fixed Jackscrews mate with any Turnable Jackscrew listed above having the same thread size.
 2. Single-lead versions are designed to mate with competitive Jackscrews.
 3. Double-Lead Thread and Single-Lead Thread Jackscrews can NOT be mixed; i.e., Double-Lead must mate with Double, Single-Lead with Single.
 4. Double-Lead Thread has two leads in the same revolution versus one lead for Single-Lead Thread. Therefore, Double-Lead Thread will pick up twice as fast.

Fastening Hardware (Continued)

Locking Springs

Material and Finish

Male (Spring Member)—Spring steel, nickel plated

Female (Latching Member)—Stainless steel

Locking Springs are used to hold mated connectors together. Although Locking Springs can be used on connectors up to 50 positions, they are primarily used on smaller size connectors (less than 34 positions).

In all applications, a Male (Spring Member) is used opposite a Female (Latching Member). They can be secured to a connector housing using Guide Pins and Sockets or 4-40 x .250 [6.35] fillister head screws and nuts. Locking Springs can be used with all hardware, except Closed-End Pin Hoods.

For Housings with Single Mounting Hole

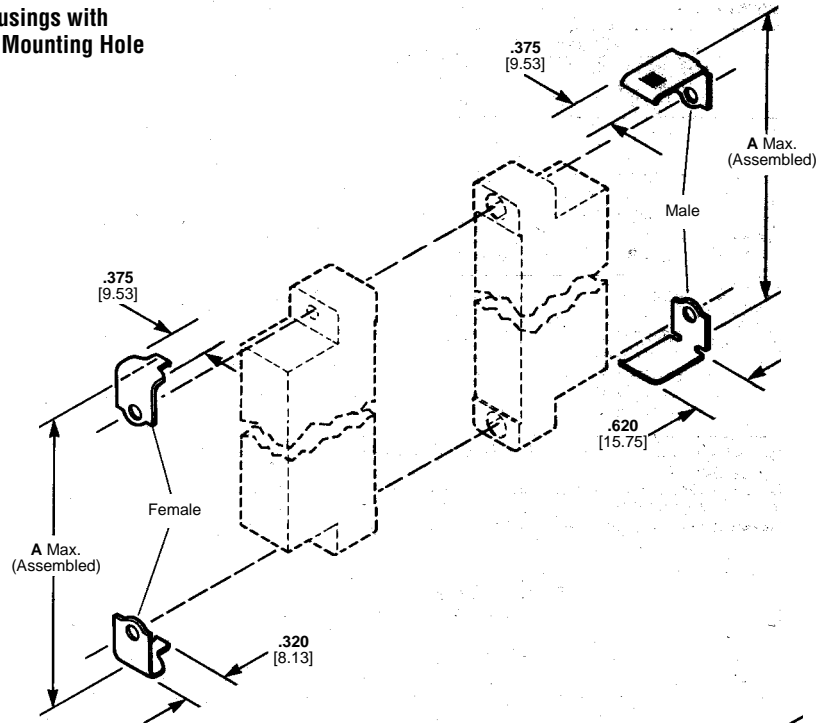

For Housings with Three Mounting Holes

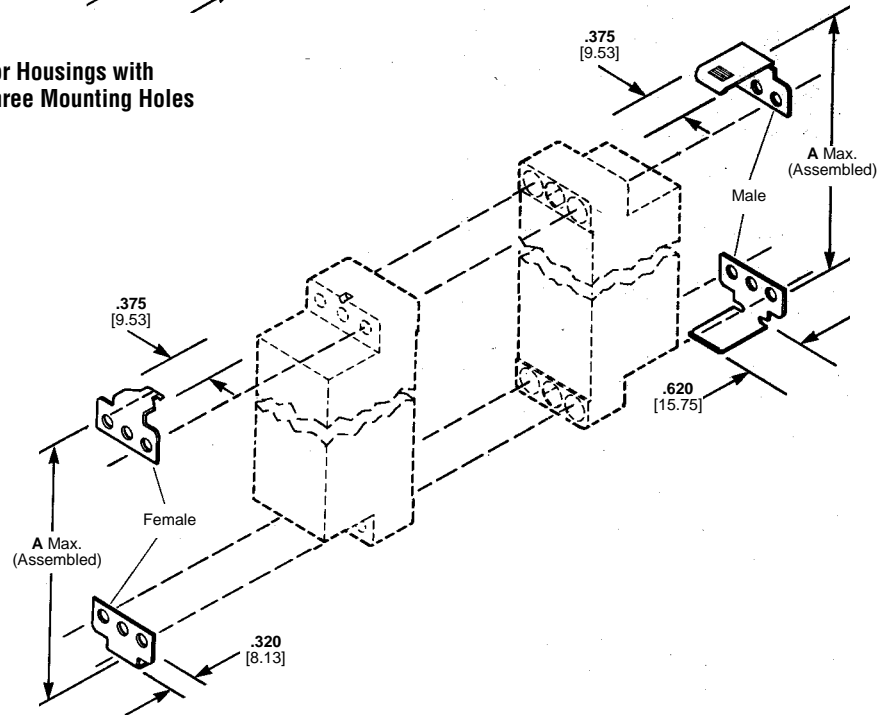

Standard Connector Size*	A Max.
6	1.413 35.89
14	1.662 42.21
20	1.975 50.17
26	2.037 51.74
34	2.412 61.26
41	3.047 77.39
50	3.006 76.35

*A dimension also applies to other comparably sized connector types listed in the chart at the right.

Locking Spring Part No.		Connectors Used On (No. of Positions)				
Male (Spring Member)	Female (Latching Member)	Standard	Posted	Special Application		
				High Current	Mixed	High Voltage
201921-1	201922-1	6, 14, 20 and 41	6, 14, 20 and 41	—	—	—
201923-1	201918-1*	26	26	—	15	—
201925-1	201926-1	34 and 50	34 and 50	—	16 and 42	20

*Single female latch, two must be ordered per assembly.

Guiding Hardware

Guide Pins and Sockets

Material and Finish

Guide Pins and Sockets—Stainless steel

Lockwashers—Stainless steel

Hex Nuts—Steel, zinc plated

Guiding hardware is used to align connector halves during mating. This hardware can also be used for keying connectors to provide for proper mating. Guiding hardware can be readily secured to connector housings using the Nut Driver Tool shown below.

Center Guide Pins and Sockets are used primarily in housings having a single mounting hole, but can also be used in the centermost hole of housings having 3 or 4 mounting holes.

Corner Guide Pins and Sockets are used in the corner holes of housings having 2, 3 or 4 mounting holes. They cannot be used in center mounting holes which are slightly deeper than corner mounting holes to accept Jackscrews.

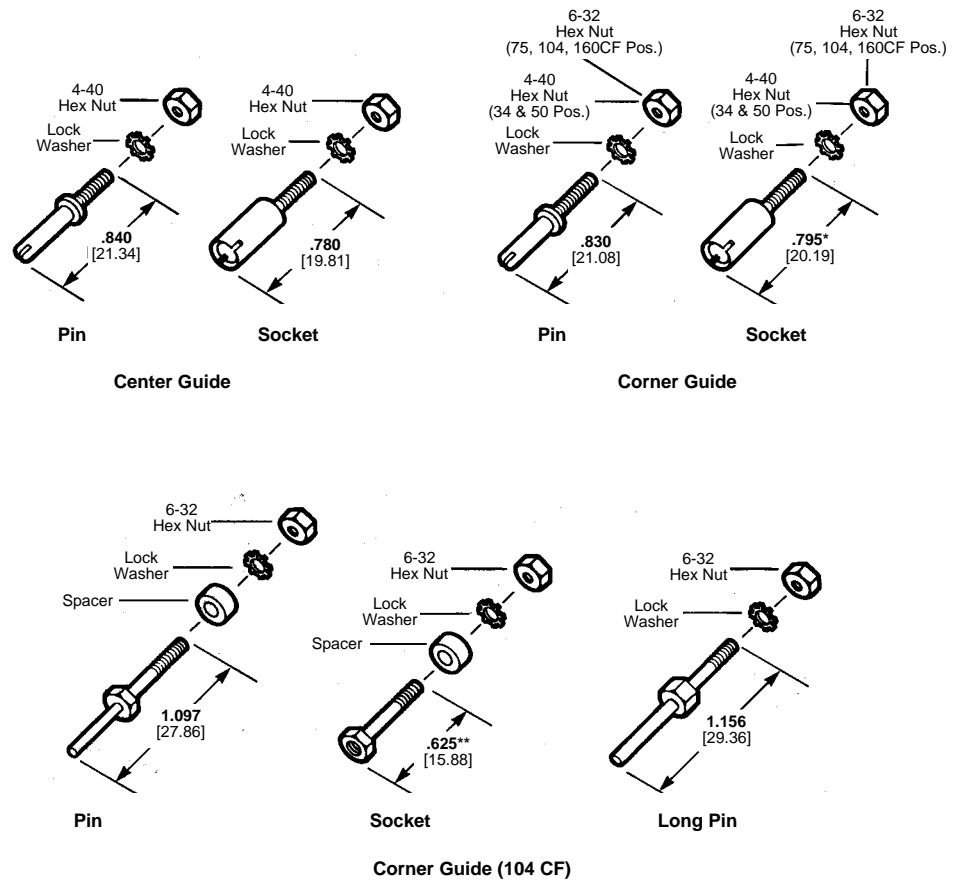

Nut Driver
Part No. 811262-1 (4-40)
Part No. 811262-2 (6-32)

Guide Pins and Sockets		Connectors Used On (No. of Positions)				
Type	Part No.	Standard	Posted	Special Application		
				High Current	Mixed	High Voltage
Center Pin	200389-2	6, 14, 20, 26, 34, 41, 50, 75 and 104	6, 14, 20, 26, 34, 41, 50, 75 and 104	12	15, 16 and 42	20 and 28
Center Socket	200390-2 207619-1* ²					
Corner Pin	200833-2	34 and 50	34 and 50	—	16 and 42	20
Corner Socket	200835-2 203964-1*					
Corner Pin	201046-2	75, 104 and 160 CF	75, 104 and 160 CF	12	29	28
Corner Socket	201047-2 203966-1*					
Corner Pin	202173-5 202173-1 ³	104 CF	104 CF	—	—	—
Corner Socket	202174-1 202174-4 ³ 204099-2**					
Long Pin ¹	201540-1					

¹Two Long Pins are to be installed in diagonal corners. Use without Guide Sockets.

²Hex Nut Stainless Steel.

³Without Spacer.

*These Corner or Center Guide Sockets (.880 [22.35] long) are to be used when housings are loaded with Subminiature COAXICON contacts.

**Corner Socket, Part No. 204099-2 (.838 [21.29] long), is to be used when housings are loaded with Subminiature COAXICON contacts.

Protective Hardware

**Pin Hoods, Internal
Open-End and Closed-End**

Material and Finish

See charts

Pin Hoods are used to protect pin contacts that protrude from a connector housing.

When contacts are mixed (pins and sockets in both housings), an Internal Pin Hood is used on one housing and an External Pin Hood (page 83) is used on the other housing. Or a Long Shield is used on one housing and an External Pin Hood must be used on the other housing. When a housing is loaded with all pin contacts, an Internal or External Pin Hood may be used—no Pin Hood is required on the mating half.

External Open-End Pin Hoods with flanges (page 83) are used primarily for mounting a connector with pin contacts to a panel.

All Pin Hoods may be secured to connector housings using other appropriate hardware, such as Jackscrews and Guide Pins and Sockets.

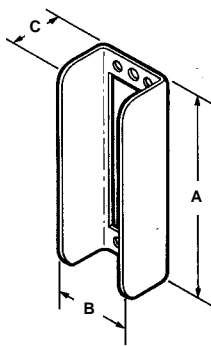

Internal Open-End

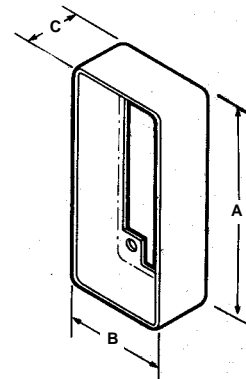

Internal Closed-End

Note: Typical Internal Open-End and Closed-End Pin Hoods are illustrated. Slight differences in configuration exist for various sizes. The mounting holes and/or slots in each Pin Hood match the mounting hole pattern of the connector housing on which the Pin Hood is used.

Pin Hoods, Internal Open-End

Dimensions			Material	Pin Hood Part No.	Connectors Used On (No. of Positions)				
A	B	C			Standard	Posted	Special Application		
						High Current	Mixed	High Voltage	
1.000 25.4	.500 12.7	.718 18.24	Nickel Plated Steel	204258-6	6	6	—	—	—
1.250 31.75	.550 13.97	.718 18.24	Nickel Plated Steel	201363-4	14	14	—	—	—
1.632 41.45	.725 18.42	.718 18.24	Nickel Plated Steel	201785-4	26	26	—	15	—
2.000 50.8	.880 22.35	.718 18.24	Nickel Plated Steel	201786-4	34	34	—	16	20

Pin Hoods, Internal Closed-End

Dimensions			Material	Pin Hood Part No.	Connectors Used On (No. of Positions)				
A	B	C			Standard	Posted	Special Application		
						High Current	Mixed	High Voltage	
2.130 54.1	.880 22.35	.687 17.45	Nickel Plated Steel	202434-4	34	34	—	16	20
2.875 73.02	.952 24.18	.687 17.45	Nickel Plated Steel	202394-2	50	50	—	42	—
2.765 70.23	1.310 33.27	.687 17.45	Nickel Plated Steel	201369-4	75	75	12	—	28
2.975 75.57	1.740 44.2	.687 17.45	Nickel Plated Steel	201364-4	104	104	—	—	—
2.975 75.57	2.040 51.82	.687 17.45	Nickel Plated Steel	203743-4	160 CF	160 CF	—	—	—

Protective Hardware (Continued)

Pin Hoods, External Closed-End and Open-End (with Flanges)

Material and Finish

See charts

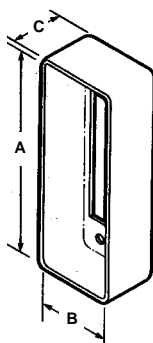

External Closed-End

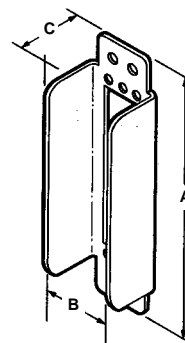

External Open-End with Flanges

Note: Typical External Closed-End and Open-End (with Flanges) Pin Hoods are illustrated. Slight differences in configuration exist for various sizes. The mounting holes and/or slots in each Pin Hood match the mounting hole pattern of the connector housing on which the Pin Hood is used.

Pin Hoods, External Closed-End

Dimensions			Material	Pin Hood Part No.	Connectors Used On (No. of Positions)				
A	B	C			Standard	Posted	Special Application		
						High Current	Mixed	High Voltage	
1.880 47.75	.812 20.62	.687 17.45	Aluminum Iridite	201349-2	26	26	—	15	—
2.250 57.15	1.000 25.4	.687 17.45	Aluminum Iridite	201350-2	34	34	—	16	20
2.845 72.26	1.000 25.4	.687 17.45	Nickel Plated Steel	201390-5	50	50	—	42	—
2.845 72.26	1.360 34.54	.687 17.45	Nickel Plated Steel	201368-4	75	75	12	29	28
3.025 76.84	1.800 45.72	.687 17.45	Nickel Plated Steel	201346-4	104	104	—	—	—
3.040 77.22	1.340 34.04	.718 18.24	Nickel Plated Steel	202119-2	104 CF	104 CF	—	—	—
3.025 76.84	2.100 53.34	.687 17.45	Nickel Plated Steel	203744-4	160 CF	160 CF	—	—	—

Pin Hoods, External Open-End with Flanges

Dimensions			Material	Pin Hood Part No.	Connectors Used On (No. of Positions)				
A	B	C			Standard	Posted	Special Application		
						High Current	Mixed	High Voltage	
2.875 73.02	.891 22.63	.687 17.45	Nickel Plated Steel	202095-5	34	34	—	16	20
3.375 85.73	.565 14.35	.687 17.45	Nickel Plated Steel	202165-5	41	41	—	—	—
3.468 88.09	.891 22.63	.687 17.45	Nickel Plated Steel	202096-5	50	50	—	42	—

Protective Hardware (Continued)

**Shields, Two-Piece,
180° and 90° Cable Exit**

Material and Finish

- Shields**—See charts
- Cable Clamp**—Steel, nickel plated
- Screws**—Steel, zinc plated

These Two-Piece Shields are used to protect connectors from dust, dirt and physical damage and to provide strain relief for the contacts. They feature integral cable clamps formed at 180° and 90° and are available in long and short versions. Long versions offer pin protection as well as connector protection and strain relief. Short versions may be used in combination with Pin Hoods to provide pin protection.

For shielding and fastening applications, Two-Piece Shields are used with Jackscrews. They may be secured to a connector housing using other appropriate hardware such as Guide Pins and Sockets.

Two-Piece Shields with cable clamps formed at 45° are available, see page 87.

Tyco does **NOT** recommend the use of shields with posted connectors because of the potential of shorting.

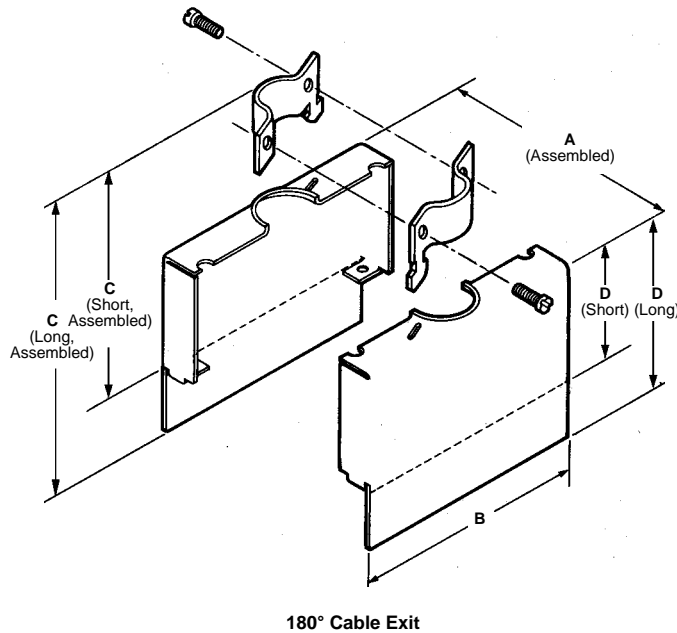

180° Cable Exit

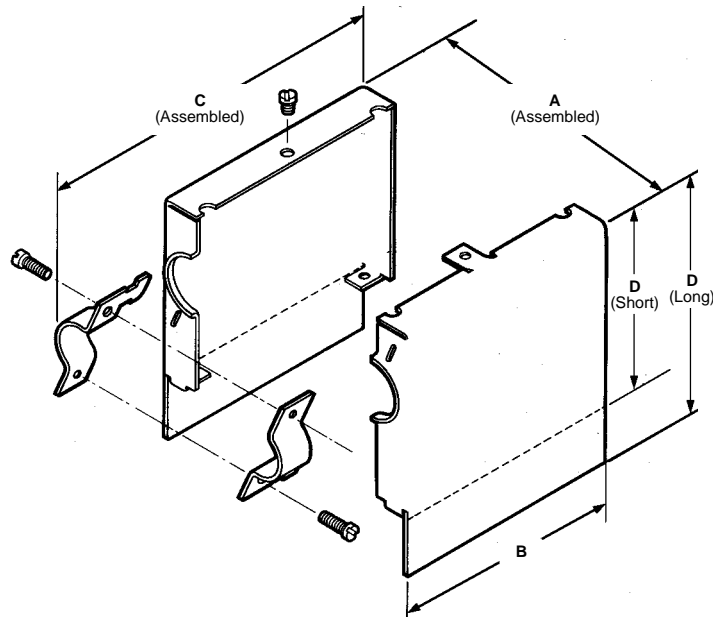

90° Cable Exit

Note: Typical 180° and 90° Cable Exit Shields are illustrated. Slight differences in configuration exist for various sizes.

Protective Hardware (Continued)

Two-Piece Shields, 180° Cable Exit (Long and Short)

Dimensions				Material	Shield Part No.		Max. Cable Dia.	Connectors Used On (No. of Positions)			
A	B	C	D		Long	Short		Standard	Special Application		
									High Current	Mixed	High Voltage
.520 13.21	1.562 39.67	1.815 46.10	1.300 33.02	Nickel Plated Steel	—	204087-1	.375 9.53	20	—	—	—
		2.453 62.31	1.970 50.04	Anodized Aluminum	201576-1	—					
.640 16.26	1.625 41.28			Nickel Plated Steel	201576-2	—	.415 10.54	26	—	15	—
		1.781 45.24	1.300 33.02	Nickel Plated Steel	—	200514-2					
		2.453 62.31	1.937 49.2	Anodized Aluminum	201571-1	—					
.828 21.03	2.000 50.8			Nickel Plated Steel	201571-2	—	.500 12.7	34	—	16	20
		1.765 44.83	1.250 31.75	Anodized Aluminum	—	200517-1					
				Nickel Plated Steel	—	200517-2					
.515 13.08	2.687 68.25	2.453 62.31	1.968 49.99	Nickel Plated Steel	202383-2	—	.435 11.05	41	—	—	—
.515 13.08	2.687 68.25	1.781 45.24	1.290 32.77	Nickel Plated Steel	—	202383-1					
		2.468 62.69	1.970 50.04	Anodized Aluminum	201443-1	—					
.828 21.03	2.593 65.86			Nickel Plated Steel	201443-2	—	.550 13.97	50	—	42	—
		1.796 45.62	1.290 32.77	Anodized Aluminum	—	200532-1					
				Nickel Plated Steel	—	200532-2					
1.195 30.35	2.727 69.27	3.327 84.51	2.797 71.04	Nickel Plated Steel	202713-2	—	1.000 25.4	75	12	—	28
		2.655 67.44	2.125 53.98	Nickel Plated Steel	—	202713-1					
1.620 41.15	2.835 72.01	3.327 84.51	2.797 71.04	Nickel Plated Steel	204173-2	—	1.100 27.94	104	—	—	—
		2.655 67.44	2.125 53.98	Nickel Plated Steel	—	204173-1					
1.703 43.26	2.765 70.23	1.843 46.81	1.290 32.77	Nickel Plated Cast Aluminum	—	201131-1	.800 20.32				

Two-Piece Shields, 90° Cable Exit (Long and Short)

Dimensions				Shield Part No.		Max. Cable Dia.	Connectors Used On (No. of Positions)				
A	B	C	D	Long	Short		Standard	Special Application			
									High Current	Mixed	High Voltage
.900 22.86	2.592 65.84	3.098 78.69	2.797 71.04	203975-2	—		.550 13.97	50	—	42	—
			2.125 53.98	—	203975-1						
1.195 30.35	2.730 69.34	3.260 82.80	2.797 71.04	202711-3	—		1.000 25.4	75	12	—	28
			2.125 53.98	—	202711-1						
1.145 29.08	2.845 72.26	3.375 85.73	2.375 60.33	—	202395-1		1.000 25.4	104 CF	—	—	—

- Notes:** 1. All parts are packaged unassembled.
2. Material: nickel plated steel.

Protective Hardware (Continued)

**Shields, One-Piece,
180° and 90° Cable Exit**

Material and Finish

Shields and Cable Clamps—Steel, nickel plated

Screws—Steel, zinc plated

One-Piece Shields are used to protect connectors from dust, dirt and physical damage and to provide strain relief for the contacts. They feature integral cable clamps formed at 180° and 90° and are available in long and short versions. Long versions offer pin protection as well as connector protection and strain relief. Short versions may be used in combination with Pin Hoods to provide pin protection.

For shielding and fastening applications, One-Piece Shields are used with Locking Springs. They cannot be used with Jackscrews. One-Piece Shields may be secured to a connector housing using other appropriate hardware such as Guide Pins and Sockets.

Tyco does **NOT** recommend the use of shields with posted connectors because of the potential of shorting.

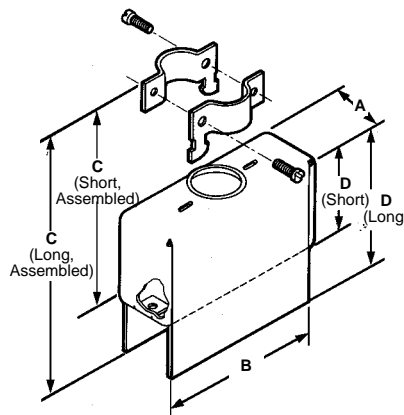

180° Cable Exit

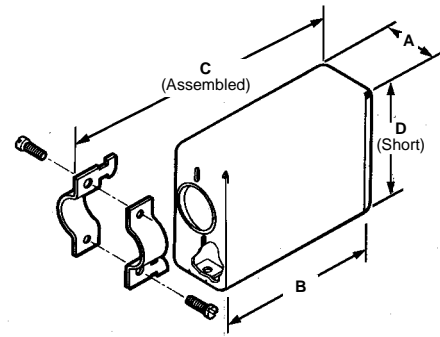

90° Cable Exit

Note: Typical 180° and 90° Cable Exit Shields are illustrated. Slight differences in configuration exist for various sizes.

One-Piece Shields, 180° Cable Exit (Long and Short)

Dimensions				Shield Part No.		Max. Cable Dia.	Connectors Used On (No. of Positions)		
A	B	C	D	Long	Short		Standard	Special Application Mixed	High Voltage
.531 13.49	1.312 33.32	2.468 62.69	1.969 50.01	201378-2	—	.375 9.53	14	—	—
		1.796 45.62	1.300 33.02	—	201360-2				
.515 13.08	1.640 41.66	1.796 45.62	1.300 33.02	—	201227-2	.350 8.89	20	—	—
		1.687 42.85	1.296 32.92	—	201169-2				
.828 21.03	2.062 52.37	2.468 62.69	1.969 50.01	201384-2	—	.500 12.7	34	16	20
		1.781 45.24	1.281 32.54	—	201165-2				

One-Piece Shields, 90° Cable Exit (Short)

Dimensions				Shield Part No.	Max. Cable Dia.	Connectors Used On (No. of Positions)		
A	B	C	D	Short		Standard	Special Application Mixed	High Voltage
.531 13.49	1.312 33.32	1.796 45.62	1.750 44.45	201467-2	.375 9.53	14	—	—
		2.062 52.37	2.562 65.07	1.812 46.02				

Note: All parts are packaged unassembled.

Protective Hardware (Continued)

**Shields, Two-Piece,
45° and 30° Cable Exit**

Material and Finish

Shields and Cable Clamps—Steel, nickel plated

Screws—Steel, zinc plated

These Two-Piece Shields are used to protect connectors from dust, dirt and physical damage and to provide strain relief for the contacts. They feature integral cable clamps formed at 45° and are specifically designed for use with 104 CF and 160 CF position standard connectors; 30° exit shield is available for 29 CF position connectors.

These Shields may be used with Pin Hoods to provide pin protection.

These Two-Piece Shields may be secured to a connector housing using other appropriate hardware such as Guide Pins and Sockets.

Tyco does **NOT** recommend the use of shields with posted connectors because of the potential of shorting.

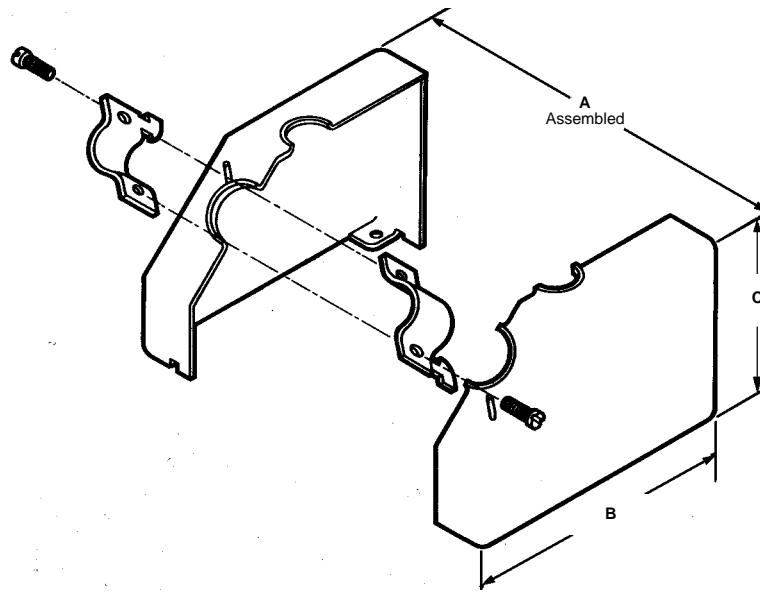

45° Cable Exit

Note: A typical 45° Cable Exit Shield is illustrated. Slight differences in configuration exist between sizes.

Two-Piece Shields, 45° Cable Exit

Dimensions			Shield Part No.	Max. Cable Dia.	Connectors Used On (No. of Positions) Standard
A	B	C			
1.145 29.08	2.845 72.26	2.375 60.33	202169-1	1.000 25.4	104 CF
		1.875 47.63	202110-1	.650 16.51	
1.845 46.86	2.770 70.36	2.750 69.85	202798-1	1.200 30.48	160 CF

Note: All parts are packaged unassembled.

Two-Piece Shield, 30° Cable Exit

Dimensions			Shield Part No.	Max. Cable Dia.	Connectors Used On (No. of Positions) Standard
A	B	C			
1.375 34.93	2.685 68.19	3.440 87.38	202483-1	1.250 31.75	29 CF

Dimensions are shown for reference purposes only.

Dimensions are in inches and millimeters unless otherwise specified. Values in brackets are metric equivalents.

Specifications subject to change.

Technical Support Center
1-800-522-6752
www.tycoelectronics.com

Strain Relief Hardware

Strain Relief Clamps

Material and Finish

- Clamp**—Steel, nickel plated
- Hex Nuts**—Steel, zinc plated
- “U” Bolt**—Stainless steel
- Sleeves**—Black plastic (neoprene)
- Bracket**—See chart

Strain Relief Clamps are used to relieve the stress of the wires on the contacts and to group the wires where they enter a connector. Both long and short versions are available. The long versions are normally used for all applications and provide a greater distance between the wire bundle and the connector for operating Jackscrews without interference. The short versions are ideally suited for applications where space is limited.

Tyco does **NOT** recommend the use of Strain Relief Clamps with posted connectors because of the potential of shorting.

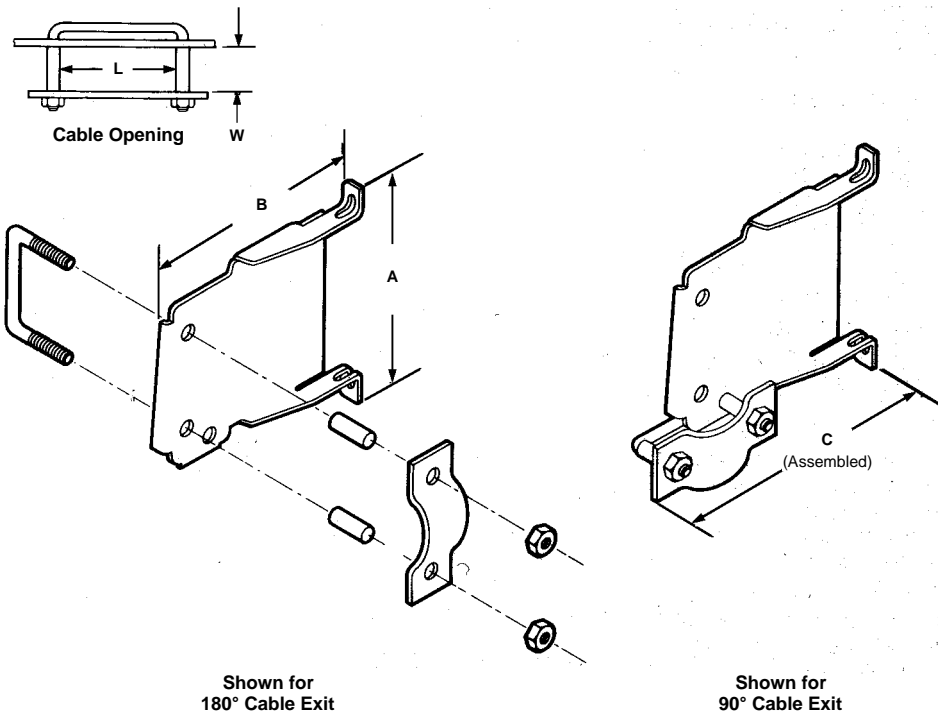

Note: A typical Strain Relief Clamp is illustrated. Slight differences in configuration exist for various sizes.

Cable Clamps (Long and Short)

Bracket Material	Dimensions			Cable Opening L x W	Strain Relief Clamp Part No.		Connectors Used On (No. of Positions)			
	A	B	C		Long	Short	Standard	Special Application High Current	Mixed	High Voltage
Steel, Nickel Plated	1.000 25.4	1.125 28.58	—	.305 x .155 7.75 x 3.94	—	203432-1	6	—	—	—
	1.250 31.75	1.125 28.58	2.687 68.25	.530 x .335 13.46 x 8.51	201843-1	—	14	—	—	—
Stainless Steel	1.562 39.67	1.187 30.15	2.000 50.8	.780 x .335 19.81 x 8.51	—	201237-1	20	—	—	—
	1.625 41.28	1.250 31.75	2.937 74.6	.780 x .505 19.81 x 12.83	201845-1	—	26	—	15	—
Steel, Nickel Plated	2.000 50.8	1.500 38.1	2.851 72.42	.780 x .500 19.81 x 12.7	201846-1	—	34	—	16	20
	2.625 66.68	2.000 50.8	3.343 84.91	1.500 x .360 38.1 x 9.14	201766-1	—	41	—	—	—
Stainless Steel	2.593 65.86	2.406 61.11	3.296 83.72	1.125 x .675 28.58 x 17.15	201847-1	—	50	—	42	—
	2.562 65.07	1.703 43.26	2.780 70.61	1.125 x .550 28.58 x 13.97	—	201182-1	75	12	—	28
Steel, Nickel Plated	2.594 65.89	2.531 64.29	3.717 94.41	1.125 x .925 28.58 x 23.5	201848-1	—	75	12	—	28
	2.750 69.85	2.531 64.29	3.389 86.08	1.125 x 1.235 28.58 x 31.37	201849-1	—	104	—	—	—

Notes: All parts are packaged unassembled.

Keying Hardware

Keying Plug (for Multimate Contact Cavities)

Material

Natural color nylon

This cylindrical keying plug is used in Multimate contact cavities that accept Type II, Type III+ and Subminiature COAXICON socket contacts. The plug protrudes from the mating face of a connector and will prevent connector halves from being mated by butting against the pin contact. The mating pin contact must be removed to provide for proper mating.

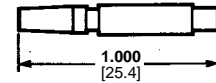
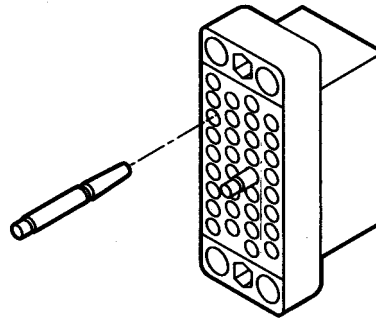

Part No. 200821-1

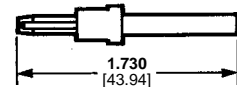
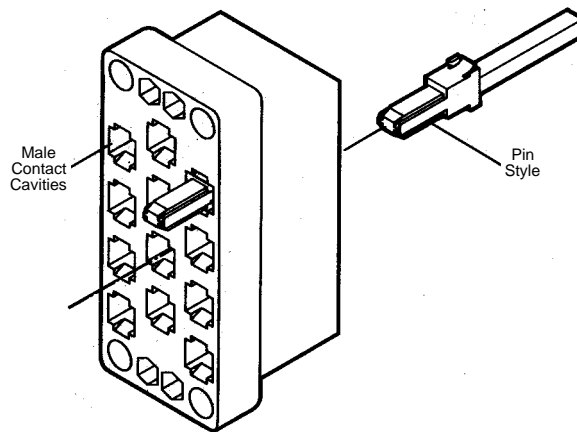

Part No. 207597-1

Keying Plugs (for Type XII Contact Cavities)

Material

For 207597-1—Gray nylon

For 206508-1—Natural color nylon

Two versions of rectangular keying plugs are available for Type XII contact cavities. A pin style is used in cavities that accept Type XII male contacts, and a plug style is used in cavities that accept Type XII female contacts. These keying plugs perform the same as the cylindrical keying plug described above. The mating contact must also be removed to provide for proper connector mating.

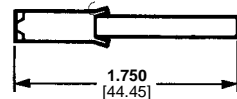
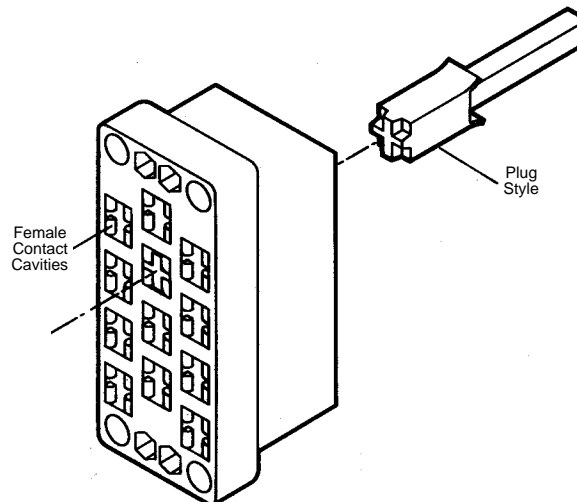

Part No. 206508-1

Application Tooling



Crimp Quality Monitor (CQM)

This unique system provides complete on-the-fly crimp inspection. It measures the crimp height of each termination, and evaluates the quality of each crimp. If a crimp is questionable, the monitor alerts the operator with both visual and audible alarms. It also provides ports for printing and networking. When used with AMP-O-LECTRIC Model "G" Termination Machines, the monitor is mounted to the machine. When used with AMPOMATOR CLS IV Lead-Making Machines, it is integrated into the machine's operating system.

For complete information, request Catalog 82275.

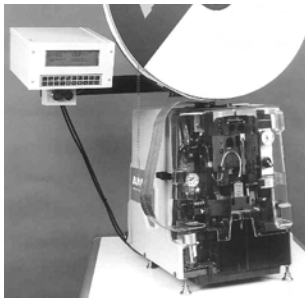

AMP-O-MATIC Stripper-Crimper Machine

Semiautomatic bench crimping machines that also strip the wire, and are therefore used for terminating jacketed cable. Feature manual precision adjustment of crimp height, keyed strip blades for faster, more accurate setups, and an efficient scrap removal system. All adjustments can be made from the front of the machines without special tools. Available with crimp quality monitoring.

For complete information, request Catalog 65004.

AMPOMATOR CLS IV+ Lead-Making Machine

Fully-automatic machines that measure, cut, strip and terminate single leads. Microprocessor-controlled, and programmed and operated using an easy-to-follow, menu-driven touch-screen. Features include direct-drive terminating units with precision crimp height adjustment, fully programmable setups, wire runout and splice detection, and motorized pre-feed with wire straightener. Crimp quality monitoring is also available.

For more information, request Catalog 124324.

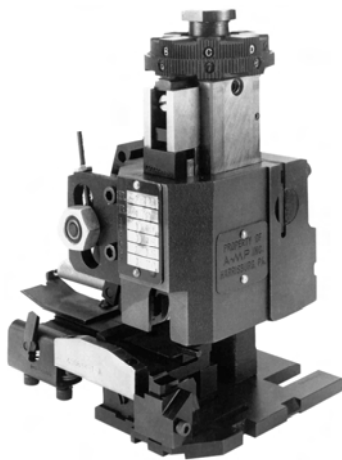
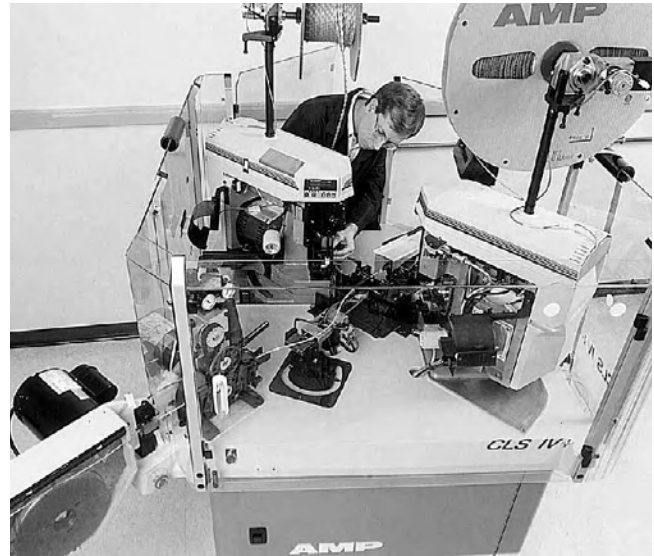

Quick-Change Applicators

Featuring a quick-change design, these various applicators can be changed in a matter of minutes to afford maximum flexibility and minimum production downtime for a wide range of AMP automatic machines. Crimp height for a given wire size is simply "dialed in."

For complete information, see specific AMP automatic machine catalog.

Need More Information?

For further information specifically about AMP tooling, call the **Technical Support Center at 1-800-522-6752.**

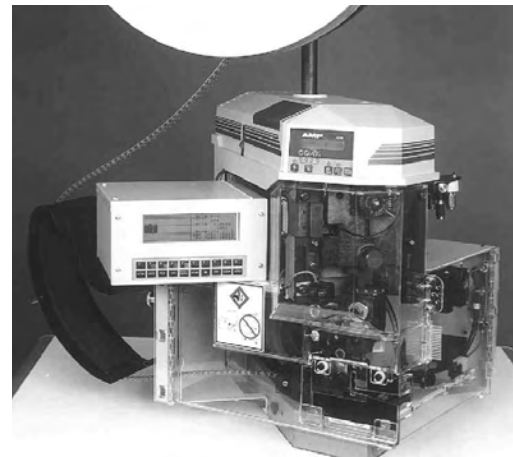

AMP-O-LECTRIC Model G Terminating Machine

Semiautomatic bench machines for crimping reeled terminals and contacts, featuring a quiet and reliable direct motor drive, microprocessor controls for ease of setup and operation, and guarding and lighting designed for operator convenience. All models are equipped with either

manual or automatic precision adjustment of crimp height. Machine-mounted sensors are available for crimp quality monitoring using conventional miniature-style applicators.

For complete information, request Catalog 65828.

Application Tooling (Continued)

Application Tooling/Technical Document Cross Reference

Part No.	Instruction Sheet
58541-1	408-4051
58495-1	408-9819
69710-1	408-2095
90310-1	408-7680
90310-2	408-7942
90310-3	408-9387
91019-3	408-7276
91067-2	408-7508
189721-2	409-5862
189722-2	409-5862
305183	408-1216



PRO-CRIMPER II Hand Tool, Part No. 58495-1

Commercial grade hand tool for crimping various products. Features ratchet control to provide complete crimp cycle. Accepts both pinned- and shouldered-style die sets. Locators are provided with pinned-style die sets for proper contact and wire positioning, and to help minimize contact rotation and bending during crimping. Approximate weight 1.3 lb [0.60 kg].

For complete information, request Catalog 82276.

CERTI-CRIMP Hand Tools

These premium tools are ideal for small production, prototype and experimental applications. They are used for terminating pin and socket contacts to wire and feature the CERTI-CRIMP ratchet device to provide for properly formed crimps.



626 Pneumatic Tool, Part No. 189721-2 (Power Unit ONLY)

For various contacts, see pages 30 thru 43.



Straight Action Hand Tool

For Type III+ contacts, see page 31.



"C" Head Straight Action Hand Tool, Part No. 69710-1

For subminiature coaxial contacts, see pages 40 & 41.

Tooling Numerical Index

Part No.	Page
45098	30
45638	43
45639	43
45740	43
58290	43
58305	30
58448	14
58495	31, 33
58541	30
69186	43
69220	43
69222	43
69227	43
69248	43
69315	43
69360	43
69373	43
69656	40,41
69672	43
69690	40,41
69710	38,40,41,43
69875	30
90066	31,33
90067	31,33
90121	36
90122	36
90136	30
90140	38
90145	38
90225	31

Part No.	Page
90230	30
90231	30
90249	30
90250	30
90265	15
90302	14
90310	31
90331	31
90374	14
90405	15
90406	14
90716	31
91002	31
91016	78
91019	38
91067	19
91285	14
126195	19
189721	30,31,33,36,38,40,41,43
189722	30,31,33,36,38,40,41,43
189928	30,31,33,36,38,40,41,43
200893	30,31,32
217201	31,33
224155	39
305183	30,31,32,35,36,37,40,41,42,59,60
318161	30,36,38,40,41,43

Part No.	Page
356114	39
356119	39
356304	30,31,33,36,38,40,41,43
356336	22
466321	31
466323	31,33
466324	31
466325	31
466326	31
466383	31
466422	14
466423	14
466585	31
466598	31
466741	33
466758	14
466900	14
466901	14
466906	31
466907	31,33
466908	31
466923	31
466942	31
466958	31
466963	14
466968	14
466979	31
567021	38
567036	14

Part No.	Page
567363	31
567364	31
567455	38
567801	14
567804	14
567849	14
567867	31
567947	31
601967	30,37
608651	21
608668	21
680114	33
680602	31
725840	33
811262	78,81
1016002	14
1016015	14

Technical Documents

The following is a list of technical documents that provide specifications, application and performance data for M Series connectors, contacts, tooling and hardware.

Product Specifications describe technical performance characteristics and verification tests. They are intended for the Design, Component and Quality Engineer.

108-10001	M Series Connectors
108-10024	CPC Connectors
108-10037	Contacts, Type XII
108-10039	Type II Contacts
108-10040	Metal-Shell CPC Connectors
108-10042	Type III+ Contacts
108-10108	Type I Contacts
108-12011	Subminiature COAXICON Contacts
108-12021	Miniature COAXICON Contacts

Application Specifications describe requirements for using the product in its intended application and/or crimping information. They are intended for the Packaging and Design Engineer and the Machine Setup Person.

114-10000	Contacts, Size 20 DF
114-10004	Type III+ Contacts, Application of
114-10005	Type XII Contacts, Application of
114-10026	Type II Contacts
114-10038	CPC Connectors

Instruction Sheets provide instructions for assembling or applying the product. They are intended for the Manufacturing Assembler or Operator.

408-1379	Selection Charts for Multimate Pin and Socket Contacts
408-7053	Selection Chart for Type I Pin and Socket Contacts
408-1770	Selection Chart for Miniature COAXICON Contacts
408-7170	6, 14, 20 and 41 Position M Series Connectors
408-7177	21 and 26 Position M Series Connectors
408-7161	34 and 50 Position and 20 Position (High Voltage) M Series Connectors
408-7164	75 and 104 Position M Series Connectors
408-7005	104 CF Position M Series Connectors
408-7293	160 CF Position M Series Connectors
408-7105	14, 20, 26 and 41 Position M Series Connector Kits
408-7107	34 and 50 Position M Series Connector Kits
408-7730	34, 50, 75 and 104 Position M Series Connector Kits
408-7108	75 and 104 Position M Series Connector Kits
408-7048	15 Position (Mixed) M Series Connectors
408-7455	29 Position (Mixed) M Series Connectors
408-6800	Shield Kit 208783-1 for 104 Position M Series Connector
408-7485	Press-Fit Jackscrews for M Series Connectors
408-7066	Locking Springs for 14, 20, 21, 26 and 41 Position M Series Connectors
408-7067	Locking Springs for 34 and 50 Position M Series Connectors
408-7055	Corner Guide Pins and Sockets for 34 and 50 Position M Series Connectors
408-7056	Corner Guide Pins and Sockets for 75 and 104 Position M Series Connectors
408-7121	Guide Pins and Sockets for 104 CF Position M Series Connectors
408-7013	Pin Hoods for M Series Connectors
408-7094	Pin Hoods w/Mounting Flange for 34 and 50 Position M Series Connectors
408-7103	Pin Hoods w/Mounting Flange for 41 Position M Series Connectors
408-7095	Pin Hoods w/Mounting Flange for 75 Position M Series Connectors

Technical Documents (Continued)

Instruction Sheets provide instructions for assembling or applying the product. They are intended for the Manufacturing Assembler or Operator. (Continued)

408-9731	M Series V.35 Cable Connector Kits
408-7089	Pin Hoods, Closed-End, for 104 CF Position M Series Connectors
408-1238	Shields (Long) for 34 and 50 Position M Series Connectors
408-1197	Shields (Short) for 34 and 50 Position M Series Connectors
408-1298	Shields, 180° (Long) for 14, 20, 26, 34 and 50 Position M Series Connectors
408-1312	Shields, 180° (Short) for 14, 20, 26, 34 and 50 Position M Series Connectors
408-1296	Shields, 90° (Long) for 14, 20, 26, 34 and 50 Position M Series Connectors
408-1297	Shields, 90° (Short) for 14, 20, 26, 34 and 50 Position M Series Connectors
408-7026	Shields, 90° (Short) for 21 and 41 Position M Series Connectors
408-1192	Shields, 180° (Long and Short) for 26 and 41 Position M Series Connectors
408-7220	Shields, 180° and 90° (Long and Short) for 75 Position M Series Connectors
408-1321	Shields, 90° (Short) for 104 Position M Series Connectors
408-7148	Shields, 90° and 45° (Long) for 104 CF Position M Series Connectors
408-7088	Shields, 45° (Short) for 104 CF Position M Series Connectors
408-7423	Shields, 45° (Short) for 160 CF Position M Series Connectors
408-7017	Strain Relief Clamps (Long) for 14 and 20 Position M Series Connectors
408-7018	Strain Relief Clamps (Long) for 26 Position M Series Connectors
408-1313	Strain Relief Clamps (Short) for 14, 20 and 26 Position M Series Connectors
408-7012	Strain Relief Clamps (Long and Short) for 21 and 41 Position M Series Connectors
408-7019	Strain Relief Clamps (Long) for 34 Position M Series Connectors
408-1317	Strain Relief Clamps (Short) for 34 and 50 Position M Series Connectors
408-7216	Strain Relief Clamps (Long) for 75 Position M Series Connectors
408-1368	Strain Relief Clamps (Short) for 75 Position M Series Connectors
408-7020	Strain Relief Clamps (Long) for 50 and 104 Position M Series Connectors
408-1322	Strain Relief Clamps (Short) for 104 Position M Series Connectors
408-1340	Keying Plug (Cylindrical) for Multimate Contact Cavities
408-6613	Application and Maintenance of AMP Hand Crimping Tool 90067
408-7414	Application and Maintenance of AMP Hand Crimping Tool 90225-2
408-7942	Application and Maintenance of AMP Hand Crimping Tool 90310-2
408-7773	Application and Maintenance of AMP Hand Crimping Tool 90331-1
408-7126	AMP Assembly Tool 91016 for Turnable Jackscrews

Part Number Index

Note: This numerical index lists all cataloged parts by base no. only. Complete part nos. (with prefixes and/or suffixes) are shown on the page(s) indicated.

Part No.	Page	Part No.	Page	Part No.	Page
50079	43	164159	33	201345	49
50080	43	164160	33	201346	83
51565	40,41	164161	33	201349	83
66098	31	164162	33	201350	83
66099	31	164163	33	201355	45
66100	31	164164	33	201356	45
66101	31	193844	37	201357	47
66102	31	193846	37	201358	47
66103	31	193990	39	201359	47
66104	31	193991	39	201360	86
66105	31	200277	47	201363	82
66106	31	200333	30	201364	82
66107	31	200336	30	201368	83
66108	31	200346	45	201369	82
66109	31	200389	81	201378	86
66180	35	200390	81	201384	86
66181	35	200512	47	201388	78
66182	35	200514	85	201389	78
66183	35	200517	85	201390	83
66253	38	200532	85	201413	78
66254	38	200686	88	201414	78
66255	38	200730	88	201443	85
66256	38	200821	89	201467	86
66259	38	200833	81	201469	86
66260	38	200835	81	201501	78
66261	38	200838	47	201511	43
66262	38	200867	78	201512	43
66331	31	200868	78	201532	50
66332	31	200870	78	201540	81
66358	31	200871	78	201568	30
66359	31	200874	79	201570	30
66360	31	200875	79	201571	85
66361	31	201037	49	201576	85
66393	31	201046	81	201578	30
66394	31	201047	81	201580	30
66399	31	201087	78	201611	30
66400	31	201088	78	201613	30
66405	31	201089	79	201692	50
66406	31	201092	79	201766	88
66424	31	201131	85	201785	82
66425	31	201142	42,43	201786	82
66428	31	201143	43	201827	78
66429	31	201144	43	201828	78
66459	32	201145	43	201843	88
66460	32	201146	43	201845	88
66461	32	201165	86	201846	88
66468	32	201169	86	201847	88
66470	32	201182	88	201848	88
66471	32	201224	88	201849	88
66473	32	201227	86	201910	78
66563	31	201229	88	201911	78
66564	31	201237	88	201918	80
66565	31	201298	45	201921	80
66566	31	201302	47	201922	80
66597	31	201310	49	201923	80
66598	31	201311	49	201925	80
66601	31	201328	30	201926	80
66602	31	201330	30	202095	83
66740	38	201332	30	202096	83
66741	38	201334	30	202110	87

Part Number Index (Continued)

Note: This numerical index lists all cataloged parts by base no. only. Complete part nos. (with prefixes and/or suffixes) are shown on the page(s) indicated.

Part No.	Page	Part No.	Page
202119	83	205508	54
202135	47	205509	54
202165	83	205511	54
202169	87	205512	54
202173	81	205514	56
202174	81	205515	57
202236	35	205516	72
202237	35	205606	60
202383	85	205628	60
202394	82	205629	60
202395	85	205630	60
202417	36	205689	76
202418	36	205690	76
202421	36	205720	59
202422	36	206508	89
202434	82	207234	78
202478	73	207235	78
202479	73	207597	89
202483	87	207619	81
202507	30	212618	30
202508	30	212810	64
202515	74	213289	65
202516	74	213300	68
202711	85	213473	66
202713	85	213513	65
202725	30	213521	59
202726	30	213522	68
202757	45	213524	66
202758	45	213550	67
202798	87	213574	64
202799	51,59	213684	70
202800	51	213685	70
203432	88	213753	68
203535	77	213763	59
203540	77	213799	47
203618	77	213800	47
203622	48,60	213801	47
203743	82	213802	47
203744	83	213803	71
203908	75	213804	71
203909	75	213805	71
203956	47,60	213806	64
203964	81	213807	64
203966	81	213808	65
203975	85	213809	66
204087	85	213931	69
204099	81	213932	69
204173	85	221848	43
204219	30	225088	40
204258	82	226537	40,41
204814	77	328663	43
205042	72	328664	43
205043	72	328666	43
205058	48	328667	43
205156	56	329029	43
205317	54	330478	43
205359	57	330587	43
205361	56	332056	40
205505	56	332057	40,41
205507	54	788085	31
		788088	31



Cover printed on recycled paper.