



(0,80mm) .0315"

MEC8-DV SERIES



MEC8-110-02-L-DV-A

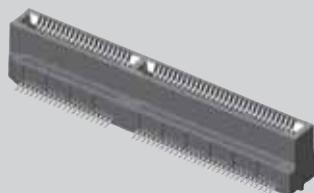

MINI EDGE CARD VERTICAL SOCKET

SPECIFICATIONS

For complete specifications and recommended PCB layouts see www.samtec.com?MEC8-DV

Insulator Material: Black LCP
Contact Material: Phosphor Bronze
Plating: Au or Sn over 50µ" (1,27µm) Ni
Operating Temp Range: -55°C to +125°C
Insertion Depth: (4,22mm) .166" to (5,66mm) .223"
Current Rating: 1.8A @ 30°C Temperature Rise
Voltage Rating: 265 VAC
RoHS Compliant: Yes



Processing:

Lead-Free Solderable: Yes
SMT Lead Coplanarity: (0,10mm) .004" max (10-50) (0,15mm) .006" max (60-70)

Mates with: (1,60mm) .062" thick cards

Mates with (1,60mm) .062" thick card

Variety of lead counts

APPLICATIONS

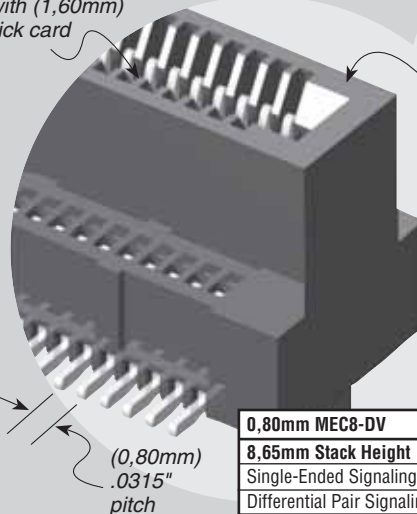
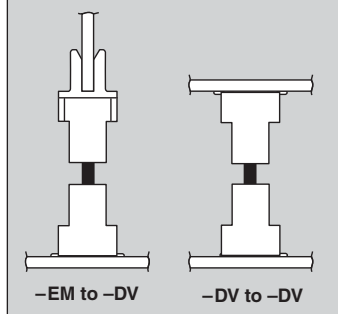

APPLICATION SPECIFIC OPTION

- 1mm mating card thickness option
- Locking clip
- Call Samtec.

0,80mm MEC8-DV	Rated @ 3dB Insertion Loss
8,65mm Stack Height	
Single-Ended Signaling	7.0 GHz / 14 Gbps
Differential Pair Signaling	7.0 GHz / 14 Gbps

For complete test data go to www.samtec.com?MEC8-DV or contact sig@samtec.com

MEC8

1

POSITIONS PER ROW

02

PLATING OPTION

DV

OTHER OPTION

10, 20, 30, 40, 50, 60, 70

-L

= 10µ" (0,25µm) Gold on contact, Matte Tin on tail

-A
= Alignment Pin

-K
= (5,50) .217" DIA Polyimide Pick & Place Pad

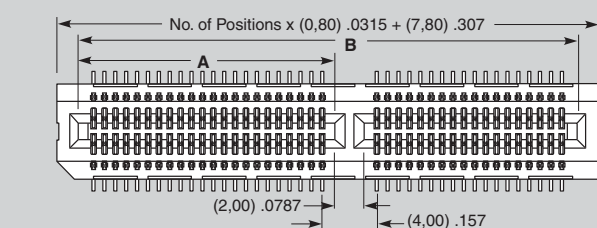

POSITIONS PER ROW	A	B
40	(18,90) .744	(36,60) 1.441
50	(22,90) .902	(44,60) 1.756
60	(26,90) 1.059	(52,60) 2.071
70	(30,90) 1.217	(60,60) 2.386

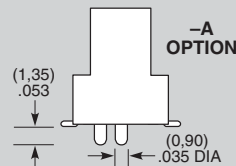
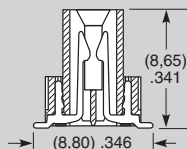
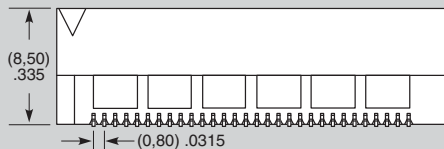
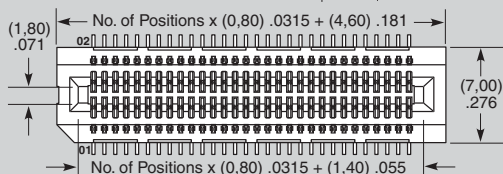

Note: Some sizes, styles and options are non-standard, non-returnable.

Due to technical progress, all designs, specifications and components are subject to change without notice.

WWW.SAMTEC.COM

SAMTEC USA • Tel: 1-800-SAMTEC-9 or 812-944-6733 SAMTEC SILICON VALLEY • Tel: 408-395-5900 SAMTEC SOUTHERN CALIFORNIA • Tel: 1-800-726-8329
 SAMTEC AMERICA LATINA COMERCIO EXTERIOR LTDA • Tel: (+55 31) 3786 3227 SAMTEC UNITED KINGDOM • Tel: 44 01236 739292 SAMTEC GERMANY • Tel: +49 (0) 89 / 89460-0
 SAMTEC FRANCE • Tel: 33 01 60 95 06 60 SAMTEC ITALY • Tel: 39 039 6890337 SAMTEC NORDIC/BALTIC • Tel: +46-84477280 SAMTEC BENELUX • Tel: 44 01236 739292 SAMTEC ISRAEL • Tel: 972-3-7526600
 SAMTEC INDIA • Tel: +91-80-3272 1612 SAMTEC ASIA PACIFIC • Tel: 65 6745-5955 SAMTEC JAPAN • Tel: 045-475-1385 SAMTEC CHINA • Tel: 86-21-61103766 SAMTEC TAIWAN • Tel: 886-2-2735-6109
 SAMTEC HONG KONG • Tel: 852-28904858 SAMTEC KOREA • Tel: 82-31-717-5685 SAMTEC ANZ • Tel: 613 9512 7747 SAMTEC SOUTH AFRICA • Tel: 27 11 452 8112