

Product number	DESCRIPTION	NOTES
10101498-XXXXLF	NON-HF	SEE SHT. 2
10101498-XXXXHFLF	HALOGEN FREE (HF)	SEE SHT. 2

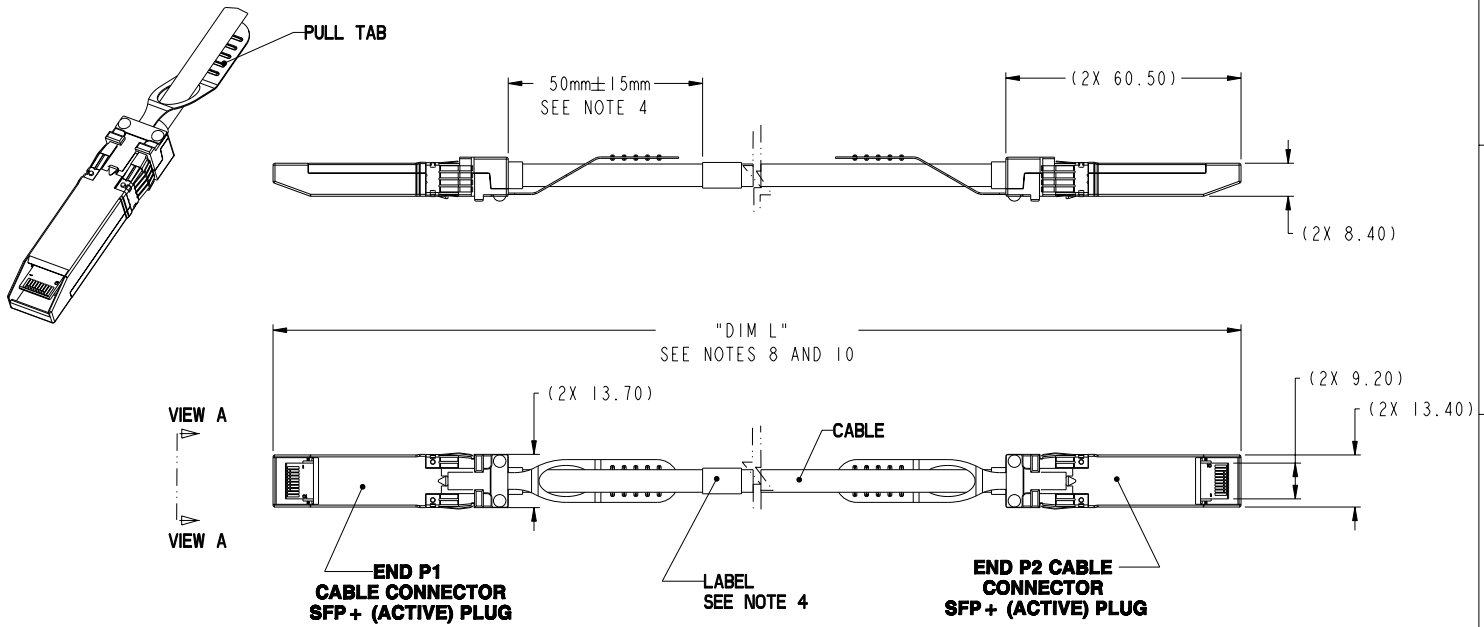

rev	ecn no	dr	date
A	V10-0242	DHL	2010-07-19
B	V10-0361	DA1	2010-09-16
-	-	-	-
-	-	-	-
-	-	-	-
-	-	-	-

www.fciconnect.com		surface	-	tolerance std	projection	mm
		TOLERANCES UNLESS OTHERWISE SPECIFIED				
Dr	D. INGRAM	2009-08-17	ANGULAR	0.X	±0.3	size A3
Eng	B. BRUBAKER	2009-08-17	LINEAR	0.XX	±0.10	Scale 3:10
Chr	B. BRUBAKER	2009-08-17	0° ±2°	0.XXX	±0.050	ECN V10-0361
Appr	B. BRUBAKER	2009-08-17	Product family	SFP+	Spec ref	
		TITLE		dwg no	10101498	Rev. B
		FINAL ASSEMBLY - ALTERNATE CABLE				
		SFP+ (ACTIVE) ASSEMBLY				
catalog no		CUSTOMER		sheet 1 of 3		

REV F - 2006-04-17

PDM: Rev:B STATUS: Released Printed: Dec 23, 2010

Copyright FCI. FCI

PART NUMBER 	LENGTH (Meters) "DIM L"	AWG	NOTES
10101498-1010LF	1.0	32	NOTE 11
10101498-1030LF	3.0	32	
10101498-1040LF	4.0	32	
10101498-1050LF	5.0	32	
10101498-2010LF	1.0	30	NOTE 11
10101498-2030LF	3.0	30	
10101498-2050LF	5.0	30	
10101498-2070LF	7.0	30	
10101498-2080LF	8.0	30	
10101498-3100LF	10.0	28	NOTE 11
10101498-5100LF	10.0	24	NOTE 11

PART NUMBER 	LENGTH (Meters) "DIM L"	AWG	NOTES
10101498-1010HF1F	1.0	32	NOTE 5
10101498-1030HF1F	3.0	32	
10101498-1040HF1F	4.0	32	
10101498-1050HF1F	5.0	32	
10101498-2010HF1F	1.0	30	NOTE 5
10101498-2030HF1F	3.0	30	
10101498-2050HF1F	5.0	30	
10101498-2070HF1F	7.0	30	
10101498-2080HF1F	8.0	30	
10101498-3100HF1F	10.0	28	NOTE 5
10101498-5100HF1F	10.0	24	NOTE 5

WIRING LIST			
END P1		END P2	
POSITION	SYMBOL	POSITION	SYMBOL
12	RD-	19	TD-
13	RD+	18	TD+
18	TD+	13	RD+
19	TD-	12	RD-

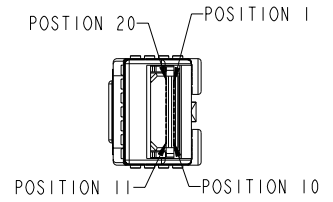

VIEW A (P1)
SCALE 2:1

LOW SPEED SIGNALS P1 & P2	
END P1	
POSITION	SYMBOL
1	VeeT
2	Tx_Fault
3	Tx_Disable
4	MOD_DEF(2)
5	MOD_DEF(1)
6	MOD_DEF(0)
7	RateSelect
8	LOS
9	VeeR
10	VeeR
11	VeeR
14	VeeR
15	VccR
16	VccT
17	VeeT
20	VeeT

	TITLE	FINAL ASSEMBLY - ALTERNATE CABLE	dwg no	10101498	Rev.	B
		SFP+ (ACTIVE) ASSEMBLY				
	CATALOG NO		CUSTOMER		SHEET 2 OF 3	

REV F - 2006-04-17

PDM: Rev:B STATUS:Released Printed: Dec 23, 2010

Copyright FCI

Product number	DESCRIPTION	NOTES
10101498-XXXXLF	NON-HF	SEE SHT. 2
10101498-XXXXHFLF	HALOGEN FREE (HF)	SEE SHT. 2

NOTES:

- 1 - MATERIAL:
 BACKSHELLS: ZINC ALLOY/ COPPER UNDERPLATE/ NICKEL OVERPLATE
 PULL TAB: THERMOPLASTIC POLYMER
 RELEASE SPRING: STAINLESS STEEL
 EMI GASKET: STAINLESS STEEL
 COLLET: BRASS
 SCREWS: STAINLESS STEEL
 PADDLE CARD: PRINTED CIRCUIT SUBSTRATE
 JET MELT: POLYIMIDE POLYMER
- 2 - THIS PRODUCT MEETS THE RESTRICTION OF HAZARDOUS SUBSTANCES IN ELECTRICAL AND ELECTRONIC EQUIPMENT (RoHS) DIRECTIVE (2002/95/EC)
- 3 - IMPEDANCE: 100 OHMS DIFFERENTIAL.
- ④ UNLESS OTHERWISE SPECIFIED LABEL POSITION IS TO BE 50mm FROM REAR OF CONNECTOR.
 LABEL DETAILS:
 MANUFACTURER CODE OR NAME COUNTRY ORIGIN
 FCI P/N
 REVISION
 DATE CODE (YY/MM/DD FORMAT) - SERIAL NUMBER
- FONT SHALL BE CLEARLY VISIBLE AND BLACK IN COLOR.
- ⑤ - "HF" PRODUCT NUMBERS DESIGNATE THE USE OF HALOGEN FREE RAW CABLE.
- 6 - CONFORMS TO FCI PRODUCT SPECIFICATION: GS-12-616.
- 7 - PACKAGING OF LEAD FREE PRODUCTS MEETS LABELING AND PACKAGING PER SPECIFICATION GS-14-920. PACKAGE CABLE ASSEMBLIES PER GS-14-1272.
- ⑧ - THIS DIMENSION IS A FINISHED PRODUCT LENGTH.
- 9. A "△" SYMBOL WILL BE NEXT TO ANY DIMENSION, VIEW, OR NOTE WHICH HAS BEEN MODIFIED WITH THE CURRENT DRAWING REVISION. THE CURRENT REVISION WILL BE SHOWN IN THE SYMBOL.
- △ ⑩ UNLESS OTHERWISE SPECIFIED ASSEMBLED LENGTH TOLERANCE IS TO BE:
 < 1 METER = ±25.0mm
 > 1 METER TO 10 METERS = ±2% OF "DIM L"
- ⑪ HALOGEN FREE RAW CABLE CAN BE USED AS A SUBSTITUTE ON NON-HF PRODUCT NUMBERS.

	title	FINAL ASSEMBLY - ALTERNATE CABLE	dwg no	10101498	Rev.	B
		SFP+ (ACTIVE) ASSEMBLY				
	catalog no		CUSTOMER		sheet 3 of 3	

REV F - 2006-04-17

PDM: Rev:B STATUS: Released Printed: Dec 23, 2010