

Product number	DESCRIPTION	NOTES
I0110818-XXXXLF	NON-HF	SEE SHT. 3
I0110818-XXXXHFLF	HALOGEN FREE (HF)	SEE SHT. 4

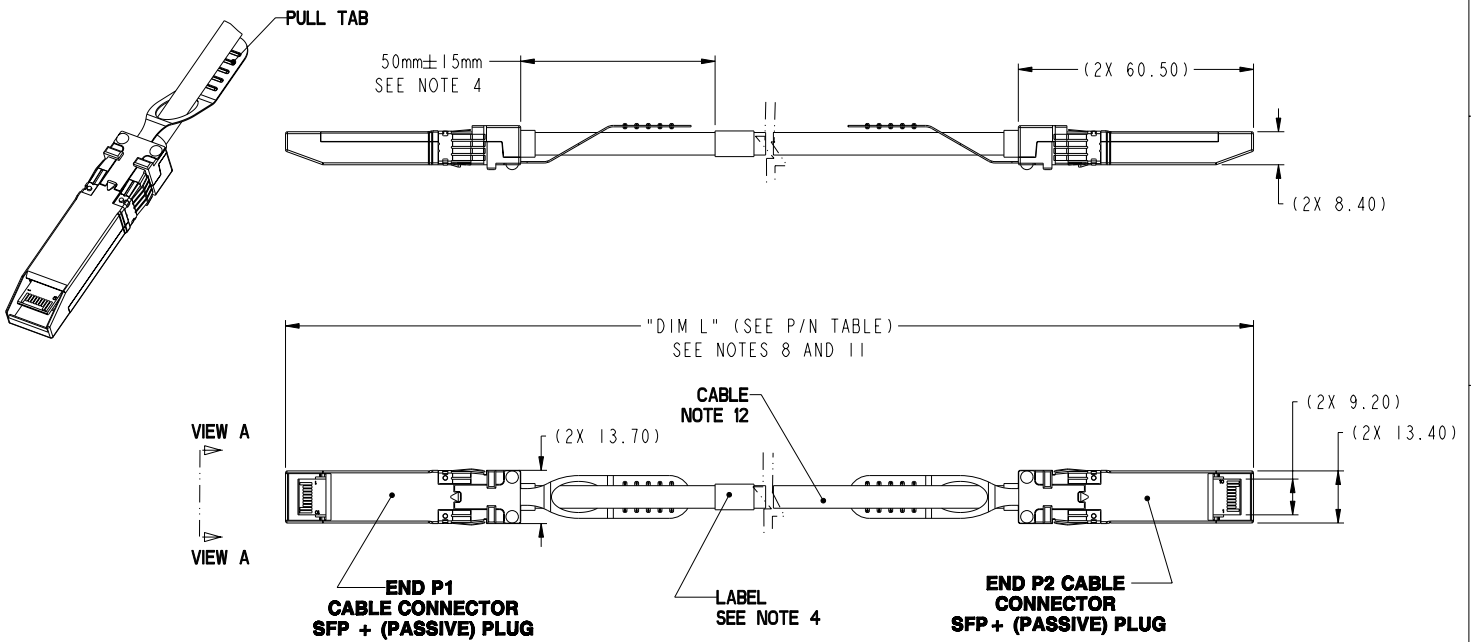

www.fciconnect.com				surface	-	tolerance std	projection	mm	
				TOLERANCES UNLESS OTHERWISE SPECIFIED					
Dr	D. INGRAM	2009-12-15		ANGULAR	0.X	±0.3	size	A3	Scale
Eng	B. BRUBAKER	2009-12-15		LINEAR	0.XX	±0.10	ECN	V10-0242	
Chr	B. BRUBAKER	2009-12-15	0° ±2°		0.XXX	±0.050	Spec ref		
Appr	B. BRUBAKER	2009-12-15		Product family		SFP+ PLUG			
				Title		FINAL ASSEMBLY - STANDARD	Rev.		
				SFP+ (PASSIVE) ASSEMBLY		10110818		B	
				catalog no		CUSTOMER	sheet 1 of 5		

rev	ecn no	dr	date
A	V10-0036	DAI	2010-01-25
B	V10-0242	DHL	2010-07-19
-	-	-	-
-	-	-	-
-	-	-	-
-	-	-	-

Copyright FCI

Product number	DESCRIPTION	NOTES
10110818-XXXXLF	NON-HF	SEE SHT. 3
10110818-XXXXHFLF	HALOGEN FREE (HF)	SEE SHT. 4

WIRING LIST (SEE NOTE 5)					
END P1			END P2		
POSITION	SYMBOL		POSITION	SYMBOL	
12	RD-	◀-----	19	TD-	
13	RD+	◀-----	18	TD+	
18	TD+	-----▶	13	RD+	
19	TD-	-----▶	12	RD-	

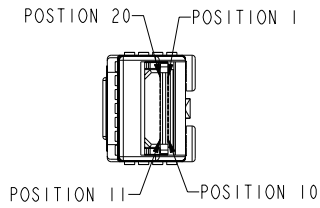

**VIEW A (P1)**  
**SCALE 2:1**

LOW SPEED SIGNALS P1 & P2	
END P1	
POSITION	SYMBOL
1	VeeT
2	TX_Fault
3	Tx_Disable
4	MOD_DEF(2)
5	MOD_DEF(1)
6	MOD_DEF(0)
7	RateSelect
8	LOS
9	VeeR
10	VeeR
11	VeeR
14	VeeR
15	VccR
16	VccT
17	VeeT
20	VeeT

	TITLE	FINAL ASSEMBLY - STANDARD	dwg no	10110818	Rev.	B
		SFP+ (PASSIVE) ASSEMBLY				
	catalog no		CUSTOMER	sheet 2 of 5		

REV F - 2006-04-11

**PDM: Rev:B** STATUS: **Released** Printed: Dec 23, 2010

Copyright FCI.

PRODUCT NUMBER	LENGTH (Meters) "DIM L"	AWG	NOTES	
I0110818-2005LF	0.5	30	NOTE 13	
I0110818-2010LF	1.0	30		
I0110818-2015LF	1.5	30		
I0110818-2020LF	2.0	30		
I0110818-2025LF	2.5	30		
I0110818-2030LF	3.0	30		
I0110818-2035LF	3.5	30		
I0110818-2040LF	4.0	30		
I0110818-3005LF	0.5	28		NOTE 13
I0110818-3010LF	1.0	28		
I0110818-3015LF	1.5	28		
I0110818-3020LF	2.0	28		
I0110818-3025LF	2.5	28		
I0110818-3030LF	3.0	28		
I0110818-3035LF	3.5	28		
I0110818-3040LF	4.0	28		
I0110818-3045LF	4.5	28		
I0110818-3050LF	5.0	28		
I0110818-4005LF	0.5	26	NOTE 13	
I0110818-4010LF	1.0	26	NOTE 13	
I0110818-4015LF	1.5	26	NOTE 13	
I0110818-4020LF	2.0	26	NOTE 13	
I0110818-4025LF	2.5	26	NOTE 13	
I0110818-4030LF	3.0	26	NOTE 13	
I0110818-4035LF	3.5	26	NOTE 13	
I0110818-4040LF	4.0	26	NOTE 13	
I0110818-4045LF	4.5	26	NOTE 13	
I0110818-4050LF	5.0	26	NOTE 13	
I0110818-4055LF	5.5	26	NOTE 13	
I0110818-4060LF	6.0	26	NOTE 13	
I0110818-4065LF	6.5	26	NOTE 10 & 13	
I0110818-4070LF	7.0	26	NOTE 10 & 13	

PRODUCT NUMBER	LENGTH (Meters) "DIM L"	AWG	NOTES
I0110818-5005LF	0.5	24	NOTE 13
I0110818-5010LF	1.0	24	NOTE 13
I0110818-5015LF	1.5	24	NOTE 13
I0110818-5020LF	2.0	24	NOTE 13
I0110818-5025LF	2.5	24	NOTE 13
I0110818-5030LF	3.0	24	NOTE 13
I0110818-5035LF	3.5	24	NOTE 13
I0110818-5040LF	4.0	24	NOTE 13
I0110818-5045LF	4.5	24	NOTE 13
I0110818-5050LF	5.0	24	NOTE 13
I0110818-5055LF	5.5	24	NOTE 13
I0110818-5060LF	6.0	24	NOTE 13
I0110818-5065LF	6.5	24	NOTE 13
I0110818-5070LF	7.0	24	NOTE 13
I0110818-5075LF	7.5	24	NOTE 13
I0110818-5080LF	8.0	24	NOTE 10 & 13
I0110818-5085LF	8.5	24	NOTE 10 & 13
I0110818-5090LF	9.0	24	NOTE 10 & 13
I0110818-5095LF	9.5	24	NOTE 10 & 13
I0110818-5100LF	10.0	24	NOTE 10 & 13

**NON-HALOGEN FREE CABLE ASSEMBLY PART NUMBERS**

	title	FINAL ASSEMBLY - STANDARD	dwg no	I0110818	Rev.	B
		SFP+ (PASSIVE) ASSEMBLY				
	catalog no		CUSTOMER		sheet 3 of 5	

**PDM: Rev:B** STATUS:Released Printed: Dec 23, 2010

PRODUCT NUMBER	LENGTH (Meters) DIM L	AWG	NOTES
10110818-2005HFLF	0.5	30	NOTE 12
10110818-2010HFLF	1.0	30	NOTE 12
10110818-2015HFLF	1.5	30	NOTE 12
10110818-2020HFLF	2.0	30	NOTE 12
10110818-2025HFLF	2.5	30	NOTE 12
10110818-2030HFLF	3.0	30	NOTE 12
10110818-2035HFLF	3.5	30	NOTE 12
10110818-2040HFLF	4.0	30	NOTE 12
10110818-3005HFLF	0.5	28	NOTE 12
10110818-3010HFLF	1.0	28	NOTE 12
10110818-3015HFLF	1.5	28	NOTE 12
10110818-3020HFLF	2.0	28	NOTE 12
10110818-3025HFLF	2.5	28	NOTE 12
10110818-3030HFLF	3.0	28	NOTE 12
10110818-3035HFLF	3.5	28	NOTE 12
10110818-3040HFLF	4.0	28	NOTE 12
10110818-3045HFLF	4.5	28	NOTE 12
10110818-3050HFLF	5.0	28	NOTE 12
10110818-4005HFLF	0.5	26	NOTE 12
10110818-4010HFLF	1.0	26	NOTE 12
10110818-4015HFLF	1.5	26	NOTE 12
10110818-4020HFLF	2.0	26	NOTE 12
10110818-4025HFLF	2.5	26	NOTE 12
10110818-4030HFLF	3.0	26	NOTE 12
10110818-4035HFLF	3.5	26	NOTE 12
10110818-4040HFLF	4.0	26	NOTE 12
10110818-4045HFLF	4.5	26	NOTE 12
10110818-4050HFLF	5.0	26	NOTE 12
10110818-4055HFLF	5.5	26	NOTE 12
10110818-4060HFLF	6.0	26	NOTE 12
10110818-4065HFLF	6.5	26	NOTE 10 & 12
10110818-4070HFLF	7.0	26	NOTE 10 & 12

PRODUCT NUMBER	LENGTH (Meters) DIM L	AWG	NOTES
10110818-5005HFLF	0.5	24	NOTE 12
10110818-5010HFLF	1.0	24	NOTE 12
10110818-5015HFLF	1.5	24	NOTE 12
10110818-5020HFLF	2.0	24	NOTE 12
10110818-5025HFLF	2.5	24	NOTE 12
10110818-5030HFLF	3.0	24	NOTE 12
10110818-5035HFLF	3.5	24	NOTE 12
10110818-5040HFLF	4.0	24	NOTE 12
10110818-5045HFLF	4.5	24	NOTE 12
10110818-5050HFLF	5.0	24	NOTE 12
10110818-5055HFLF	5.5	24	NOTE 12
10110818-5060HFLF	6.0	24	NOTE 12
10110818-5065HFLF	6.5	24	NOTE 12
10110818-5070HFLF	7.0	24	NOTE 12
10110818-5075HFLF	7.5	24	NOTE 12
10110818-5080HFLF	8.0	24	NOTE 10 & 12
10110818-5085HFLF	8.5	24	NOTE 10 & 12
10110818-5090HFLF	9.0	24	NOTE 10 & 12
10110818-5095HFLF	9.5	24	NOTE 10 & 12
10110818-5100HFLF	10.0	24	NOTE 10 & 12

**HALOGEN FREE CABLE ASSEMBLY PART NUMBERS**

	title	FINAL ASSEMBLY - STANDARD	dwg no	10110818	Rev.	B
		SFP+ (PASSIVE) ASSEMBLY				
	catalog no		CUSTOMER	sheet 4 of 5		

PDM: Rev:B STATUS:Released Printed: Dec 23, 2010

Product number	DESCRIPTION	NOTES
10110818-XXXXLF	NON-HF	SEE SHT. 3
10110818-XXXXHFLF	HALOGEN FREE (HF)	SEE SHT. 4

NOTES:

1 - MATERIAL:  
 BACKSHELLS: ZINC ALLOY/ COPPER UNDERPLATE/ NICKEL OVERPLATE  
 PULL TAB: THERMOPLASTIC POLYMER  
 RELEASE SPRING: STAINLESS STEEL  
 EMI GASKET: STAINLESS STEEL  
 COLLET: BRASS  
 SCREWS: STAINLESS STEEL  
 PADDLE CARD: PRINTED CIRCUIT SUBSTRATE  
 JET MELT: POLYIMIDE POLYMER

2 - THIS PRODUCT MEETS THE RESTRICTION OF HAZARDOUS SUBSTANCES IN ELECTRICAL AND ELECTRONIC EQUIPMENT (RoHS) DIRECTIVE (2002/95/EC)

3 - IMPEDANCE: 100 OHMS DIFFERENTIAL.

④ UNLESS OTHERWISE SPECIFIED LABEL POSITION IS TO BE 50mm FROM REAR OF CONNECTOR.

LABEL DETAILS:  
 MANUFACTURER CODE OR NAME COUNTRY ORIGIN  
 FCI P/N  
 REVISION  
 DATE CODE (YY/MM/DD FORMAT) - SERIAL NUMBER

FONT SHALL BE CLEARLY VISIBLE AND BLACK IN COLOR.

△ ⑤ ALL CABLE ASSEMBLIES SHALL BE 100% TESTED FOR CONTINUITY AS DEFINED IN WIRING LIST.  
 ALL CABLE ASSEMBLIES SHALL BE 100% HI-POT TESTED.

6 - CONFORMS TO FCI PRODUCT SPECIFICATION: GS-12-616.

7 - PACKAGING OF LEAD FREE PRODUCTS MEETS LABELING AND PACKAGING PER SPECIFICATION GS-14-920.  
 PACKAGE CABLE ASSEMBLIES PER GS-14-1272.

⑧ THIS DIMENSION IS A FINISHED PRODUCT LENGTH.

9. A "△" SYMBOL WILL BE NEXT TO ANY DIMENSION, VIEW, OR NOTE WHICH HAS BEEN MODIFIED WITH THE CURRENT DRAWING REVISION. THE CURRENT REVISION WILL BE SHOWN IN THE SYMBOL.

⑩ LONGER LENGTH APPLICATIONS REQUIRE HOST SYSTEM PREMPHASIS AND/OR EQUALIZATION.

⑪ UNLESS OTHERWISE SPECIFIED ASSEMBLED LENGTH TOLERANCE IS TO BE:  
 < 1 METER = ±25.0mm  
 > 1 METER TO 10 METERS = ±2% OF "DIM L"

⑫ "HF" PRODUCT NUMBERS DESIGNATE THE USE OF HALOGEN FREE RAW CABLE.

⑬ HALOGEN FREE RAW CABLE CAN BE USED AS A SUBSTITUTE ON NON-HF PRODUCT NUMBERS.

	title	FINAL ASSEMBLY - STANDARD	dwg no	10110818	Rev.	B
	catalog no	SFP+ (PASSIVE) ASSEMBLY	-	CUSTOMER	sheet	5 of 5

REV F - 2006-04-17