

Tous droits réservés. Reproduction ou communication sans autorisation écrite de FCI est formellement interdite.  
 All rights reserved. Reproduction or communication without written authority from FCI is strictly prohibited.  
 Alle Rechte vorbehalten. Reproduktion, Verbreitung oder Kommunikation ohne schriftliche Genehmigung der FCI ist ausdrücklich untersagt.  
 All rights strictly reserved. Reproduction or communication without written authority from FCI is strictly prohibited.  
 Property of FCI b.v. © FCI b.v.

PRODUCT NUMBER	PCB THICKNESS	DIM A	DIM B	IMPEDANCE
70212-001LF	1.6	5.90	5.58	75 Ohm
70212-002LF	2.4	6.70	6.38	75 Ohm
70212-003LF	3.2	7.50	7.18	75 Ohm
70212-004LF	4.0	8.30	7.98	75 Ohm
70212-005LF	4.8	9.10	8.78	75 Ohm
70212-006LF	5.6	9.90	9.58	75 Ohm

PLATING CONTACT AREA  
1.3um Au MIN

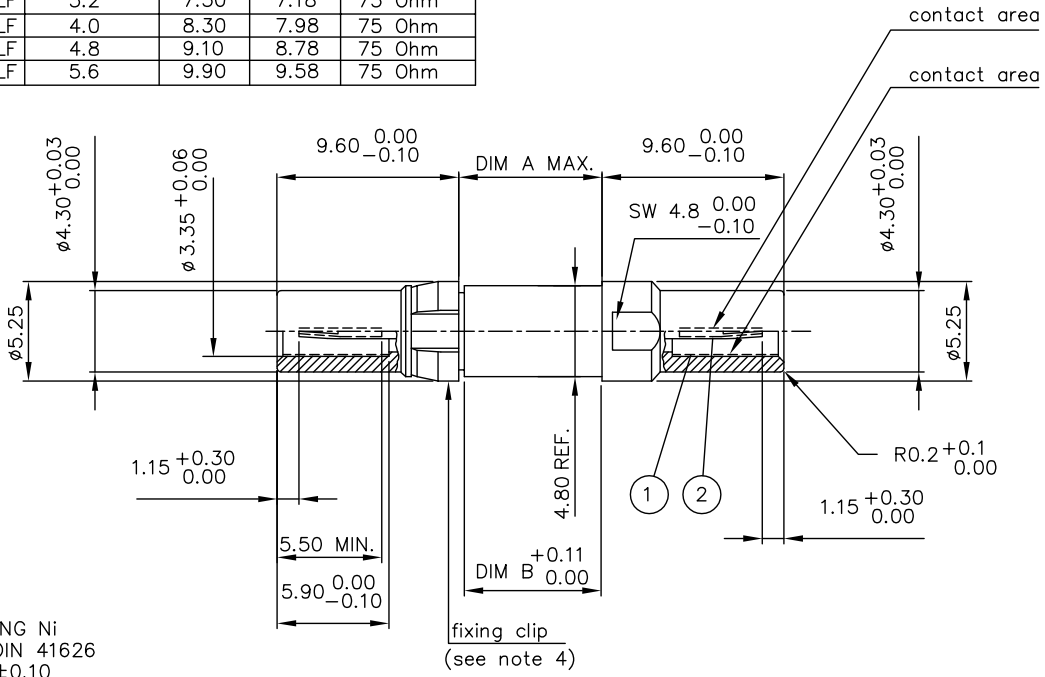

- NOTES:
- 1 UNDERPLATING Ni
  - 2 DIM. ACC. DIN 41626
  - 3 GEN. TOL. ±0.10
  - 4 FIXING CLIP PLATED WITH GOLD FLASH FOR IDENTIFICATION PURPOSES
  - 5 THIS PRODUCT WITH "LF" SUFFIX MEETS EUROPEAN UNION DIRECTIVES AND OTHER COUNTRY REGULATIONS AS DESCRIBED IN GS -22-008.
  - 6 THE PRODUCT IS NOT INTENDED TO BE EXPOSED TO A MANUFACTURE AND SOLDER PROCESS.

fixing clip  
(see note 4)

mat'l. code		tolerances unless otherwise specified		CUSTOMER COPY		FCI ELECTRONICS	
ltr	ecn no	dr	date	linear	projection	title	
A	H00365	DAN	900718			DIN COAX RCP COUPLER	
B	H00367	DAN	900731			product family	
C	H20027	DAN	920116	angles		ETRAL(tm)	
D	H20350	DAN	920609	dr	D Andrews	900718	code
E	H50483	RVI	950828	engr	P Schalk	950821	213
F	H60443	RDK	960716	chr	A v Zanten	900718	sheet
G	bc05-0342	CLU	050920	app	v Woensel	900718	1 of 1
sheet	revision						
index	sheet	1					

PQM: Rev:G STATUS Released Printed: Oct 01, 2000

form: A3