

# Male Style M

## Series 8483 – Fully loaded

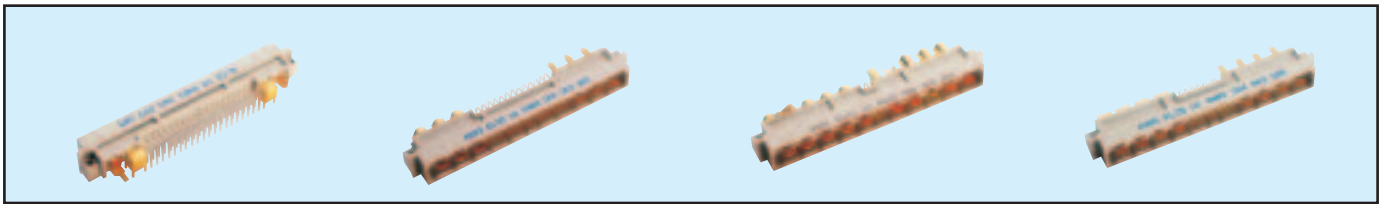

Contact Design and Termination Length	No. of Cavities For Signal Contacts	No. of Cavities for Special Contacts	Loading Description	Part Number Performance classes according to DIN 41612	
				II	I
3.0 mm (Y) Straight	6 (3 x 2)	10	a + b + c fully loaded	10 8483 006 001 025	10 8483 006 001 049
	24 (3 x 8)	8	a + b + c fully loaded	10 8483 024 001 025	10 8483 024 001 049
	42 (3 x 14)	6	a + b + c fully loaded	10 8483 042 001 025	10 8483 042 001 049
	60 (3 x 20)	4	a + b + c fully loaded	10 8483 060 001 025	10 8483 060 001 049
	78 (3 x 26)	2	a + b + c fully loaded	10 8483 078 001 025	10 8483 078 001 049
11.4 mm (Y) Straight	6 (3 x 2)	10	a + b + c fully loaded	10 8483 006 002 025	10 8483 006 002 049
	24 (3 x 8)	8	a + b + c fully loaded	10 8483 024 002 025	10 8483 024 002 049
	42 (3 x 14)	6	a + b + c fully loaded	10 8483 042 002 025	10 8483 042 002 049
	60 (3 x 20)	4	a + b + c fully loaded	10 8483 060 002 025	10 8483 060 002 049
	78 (3 x 26)	2	a + b + c fully loaded	10 8483 078 002 025	10 8483 078 002 049
3.0 mm (Y) Right Angled	6 (3 x 2)	10	a + b + c fully loaded	10 8483 006 003 025	10 8483 006 003 049
	24 (3 x 8)	8	a + b + c fully loaded	10 8483 024 003 025	10 8483 024 003 049
	42 (3 x 14)	6	a + b + c fully loaded	10 8483 042 003 025	10 8483 042 003 049
	60 (3 x 20)	4	a + b + c fully loaded	10 8483 060 003 025	10 8483 060 003 049
	78 (3 x 26)	2	a + b + c fully loaded	10 8483 078 003 025	10 8483 078 003 049
11.3mm (Y) Right Angled	6 (3 x 2)	10	a + b + c fully loaded	10 8483 006 004 025	10 8483 006 004 049
	24 (3 x 8)	8	a + b + c fully loaded	10 8483 024 004 025	10 8483 024 004 049
	42 (3 x 14)	6	a + b + c fully loaded	10 8483 042 004 025	10 8483 042 004 049
	60 (3 x 20)	4	a + b + c fully loaded	10 8483 060 004 025	10 8483 060 004 049
	78 (3 x 26)	2	a + b + c fully loaded	10 8483 078 004 025	10 8483 078 004 049
Solder hole rows a + c 6.1 mm row b 8.8 mm	6 (3 x 2)	10	a + b + c fully loaded	10 8483 006 006 025	10 8483 006 006 049
	24 (3 x 8)	8	a + b + c fully loaded	10 8483 024 006 025	10 8483 024 006 049
	42 (3 x 14)	6	a + b + c fully loaded	10 8483 042 006 025	10 8483 042 006 049
	60 (3 x 20)	4	a + b + c fully loaded	10 8483 060 006 025	10 8483 060 006 049
	78 (3 x 26)	2	a + b + c fully loaded	10 8483 078 006 025	10 8483 078 006 049

NB: Additional Plating & Loading Variations: Please contact your local AVX sales office or distributor.

### LOADING DESCRIPTION

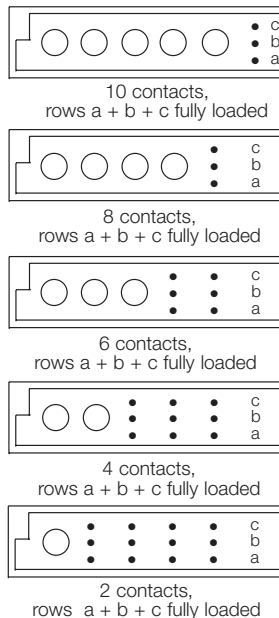

### DIMENSIONS

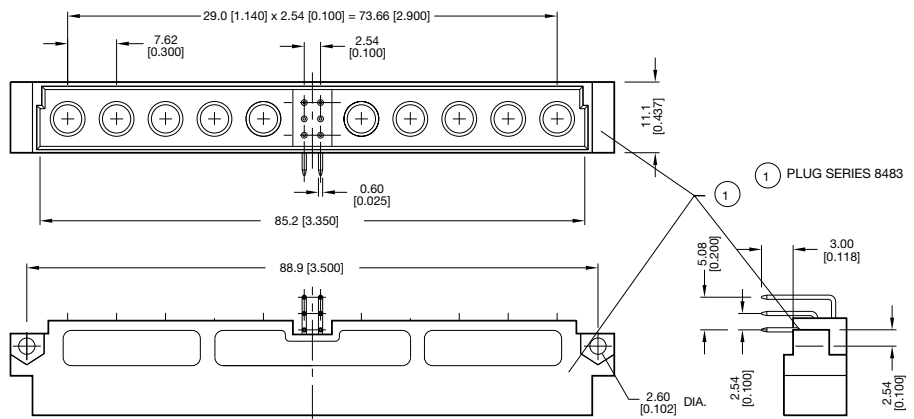

See Page 45 for board layout

# Style M Connectors

## Board Layouts



### STYLE 1/2 M

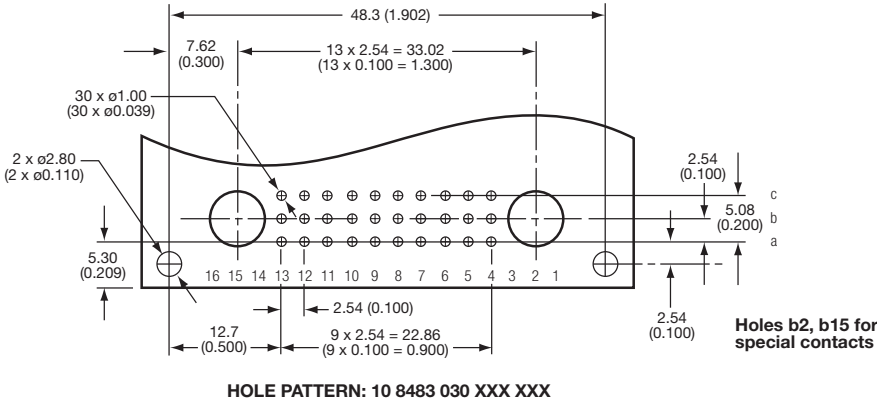
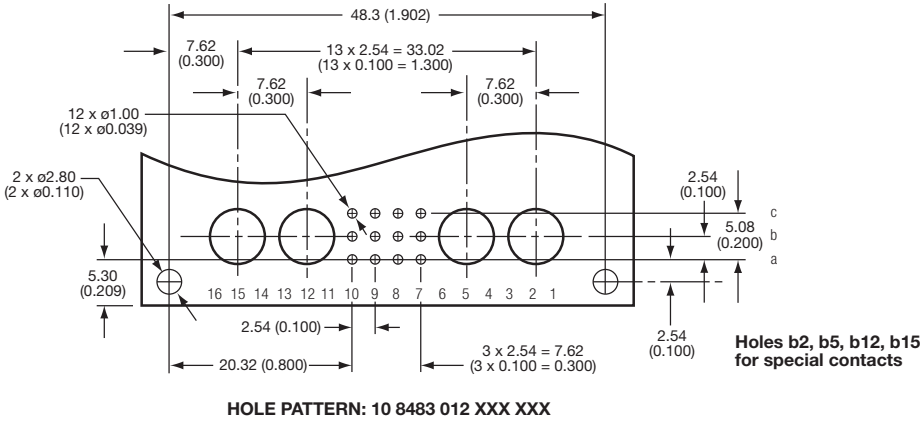

### STYLE M

