

# Amphenol

EP / AP / SP SERIES

EP METAL TYPE - SOLDER



The EP Series has set the standard in high performance speaker connectors. Apart from its durability and strength, it offers consistent superior power handling capabilities.



**Features:**



- Solder Bucket connections.
- Precision machined contacts.
- Diecast Metal Housings
- High current contacts
- Male and female cable and chassis connectors available.

**Options:** Black Finish Shell.

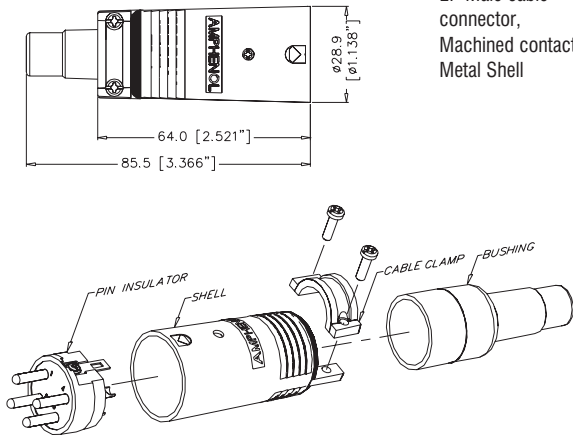
**Specifications:** Page 77-78

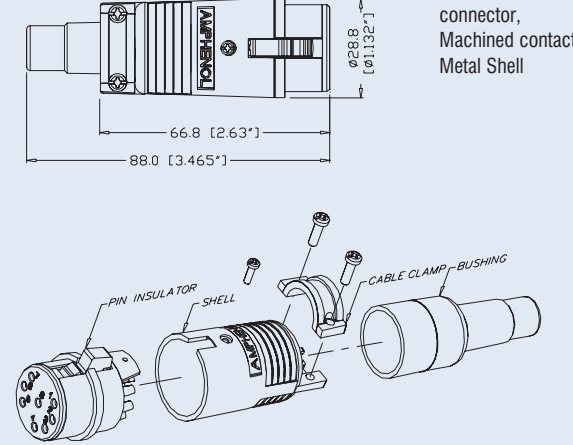
**Panel Cutouts:** Page 78

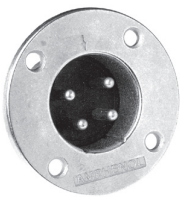
| PRODUCT - FIGURE  | DRAWING  | Dimensions in mm (inches)  | DESCRIPTION          | VARIATIONS | PART NUMBER |
|---|--|--|----------------------|------------|-------------|
|  <p><b>ISO ASSEMBLY OF EP MALE</b></p>     |   | <p>EP Male cable connector, Machined contacts, Metal Shell</p>   | 3 pole nickel finish | EP-3-12    |             |
|   |  |  | 3 pole black finish  | EP-3-12B   |             |
|   |  |  | 4 pole nickel finish | EP-4-12    |             |
|   |  |  | 4 pole black finish  | EP-4-12B   |             |
|   |  |  | 5 pole nickel finish | EP-5-12    |             |
|   |  |  | 5 pole black finish  | EP-5-12B   |             |
|   |  |  | 6 pole nickel finish | EP-6-12    |             |
|   |  |  | 6 pole black finish  | EP-6-12B   |             |
|  <p><b>ISO ASSEMBLY OF EP FEMALE</b></p> |  | <p>EP Female cable connector, Machined contacts, Metal Shell</p> | 3 pole nickel finish | EP-3-11P   |             |
|   |  |  | 3 pole black finish  | EP-3-11PB  |             |
|   |  |  | 4 pole nickel finish | EP-4-11P   |             |
|   |  |  | 4 pole black finish  | EP-4-11PB  |             |
|   |  |  | 5 pole nickel finish | EP-5-11P   |             |
|   |  |  | 5 pole black finish  | EP-5-11PB  |             |
|   |  |  | 6 pole nickel finish | EP-6-11P   |             |
|   |  |  | 6 pole black finish  | EP-6-11PB  |             |
| 8 pole nickel finish  | EP-8-11P   |  |                      |            |             |
| 8 pole black finish   | EP-8-11PB  |  |                      |            |             |

| PRODUCT - FIGURE   | DRAWING | Dimensions in mm (inches)        | DESCRIPTION  | VARIATIONS           | PART NUMBER |
|--|---------|----------------------------------|--|----------------------|-------------|
|   |         | <p>Dimensions in mm (inches)</p> | <p>EP Male chassis mount, Round Flange, Machined contacts, Metal Shell</p>   | 3 pole nickel finish | EP-3-14     |
|  |         |                                  |  | 3 pole black finish  | EP-3-14B    |
|  |         |                                  |  | 4 pole nickel finish | EP-4-14     |
|  |         |                                  |  | 4 pole black finish  | EP-4-14B    |
|  |         |                                  |  | 5 pole nickel finish | EP-5-14     |
|  |         |                                  |  | 5 pole black finish  | EP-5-14B    |
|  |         |                                  |  | 6 pole nickel finish | EP-6-14     |
|  |         |                                  |  | 6 pole black finish  | EP-6-14B    |
|  |         |                                  |  | 8 pole nickel finish | EP-8-14     |
|  |         |                                  |  | 8 pole black finish  | EP-8-14B    |
|  |         | <p>Dimensions in mm (inches)</p> | <p>EP Female chassis mount, Round Flange, Machined contacts, Metal Shell</p> | 3 pole nickel finish | EP-3-13P    |
|  |         |                                  |  | 3 pole black finish  | EP-3-13PB   |
|  |         |                                  |  | 4 pole nickel finish | EP-4-13P    |
|  |         |                                  |  | 4 pole black finish  | EP-4-13PB   |
|  |         |                                  |  | 5 pole nickel finish | EP-5-13P    |
|  |         |                                  |  | 5 pole black finish  | EP-5-13PB   |
|  |         |                                  |  | 6 pole nickel finish | EP-6-13P    |
|  |         |                                  |  | 6 pole black finish  | EP-6-13PB   |
|  |         |                                  |  | 8 pole nickel finish | EP-8-13P    |
|  |         |                                  |  | 8 pole black finish  | EP-8-13PB   |





The AP Series provides the same power handling performance as the EP Series in a cost effective, yet durable Thermoplastic housing.

**Features:**

- Solder Bucket connections.
- Precision machined contacts.
- Thermoplastic Housings
- High current contacts
- Male & Female Cable and Chassis connectors available.

**Specifications: Page 77-78**

**Panel Cutouts: Page 78**

| PRODUCT - FIGURE | DRAWING | Dimensions in mm (inches)  | DESCRIPTION  | VARIATIONS | PART NUMBER |
|------------------|---------|--|--|------------|-------------|
|                  |         | 28.8 [1.135"]<br>100.0 [3.937"]  | AP Male cable connector, Machined contacts, Thermoplastic Black shell.                     | 4 pole     | AP-4-12     |
|                  |         |  |  | 5 pole     | AP-5-12     |
|                  |         |  |  | 6 pole     | AP-6-12     |
|                  |         |  |  | 8 pole     | AP-8-12     |
|                  |         | 28.8 [1.132"]<br>98.7 [3.886"]   | AP Female cable connector, Machined contacts, Thermoplastic Black shell.                   | 4 pole     | AP-4-11     |
|                  |         |  |  | 5 pole     | AP-5-11     |
|                  |         |  |  | 6 pole     | AP-6-11     |
|                  |         |  |  | 8 pole     | AP-8-11     |
|                  |         | 29.2 [1.15"]<br>50.8 [2"]<br>32.4 [1.276"]<br>30.6 [1.204"]<br>2.8 [1.1"]<br>6.2 [244"]<br>31.8 [1.252"]                                     | AP Male chassis mount, Round Flange, Machined contacts, Thermoplastic Black shell.         | 4 pole     | AP-4-14     |
|                  |         |  |  | 5 pole     | AP-5-14     |
|                  |         |  |  | 6 pole     | AP-6-14     |
|                  |         |  |  | 8 pole     | AP-8-14     |
|                  |         | 29.2 [1.148"]<br>50.8 [2"]<br>7.5 [295"]<br>32.4 [1.276"]<br>38.3 [1.508"]<br>2.8 [1.1"]<br>6.2 [244"]<br>36.5 [1.438"]                      | AP Female chassis mount, Round Flange, Machined contacts, Thermoplastic Black shell.       | 4 pole     | AP-4-13     |
|                  |         |  |  | 5 pole     | AP-5-13     |
|                  |         |  |  | 6 pole     | AP-6-13     |
|                  |         |  |  | 8 pole     | AP-8-13     |
|                  |         | 29.2 [1.148"]<br>50.0 [1.969"]<br>40.0 [1.575"]<br>32.4 [1.276"]<br>30.6 [1.204"]<br>2.8 [1.1"]<br>6.2 [244"]<br>31.8 [1.252"]               | AP Male chassis mount, Rectangular Flange, Machined contacts, Thermoplastic Black shell.   | 4 pole     | AP-4-22     |
|                  |         |  |  | 5 pole     | AP-5-22     |
|                  |         |  |  | 6 pole     | AP-6-22     |
|                  |         |  |  | 8 pole     | AP-8-22     |
|                  |         | 29.2 [1.148"]<br>50.0 [1.969"]<br>40.0 [1.575"]<br>7.5 [295"]<br>32.4 [1.276"]<br>38.3 [1.508"]<br>2.8 [1.1"]<br>6.2 [244"]<br>36.5 [1.438"] | AP Female chassis mount, Rectangular Flange, Machined contacts, Thermoplastic Black shell. | 4 pole     | AP-4-21     |
|                  |         |  |  | 5 pole     | AP-5-21     |
|                  |         |  |  | 6 pole     | AP-6-21     |
|                  |         |  |  | 8 pole     | AP-8-21     |

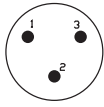
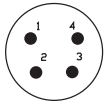
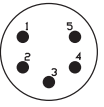
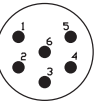
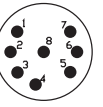

## STANDARD DATA EP/AP

|                                   |  | VALUE   |   |   |   |   |
|-----------------------------------|--|---|---|---|---|---|
| <b>GENERAL CHARACTERISTICS</b>    | Number of contacts                                 | 3   | 4   | 5   | 6   | 8   |
|                                   | Contact Arrangements<br>(Front view of pin insert) |  |  |  |  |  |
|                                   | Termination  | SOLDER  |   |   |   |   |
|                                   | Wire Gauge - Stranded wire:                        | 12AWG   | 12AWG   | 12AWG   | 12AWG   | 14AWG   |
|                                   | Flammability                                       | UL94V-0   |   |   |   |   |
| Environmental                     | Complies with RoHS Directive 2002/95/EC            |   |   |   |   |   |
| <b>ELECTRICAL CHARACTERISTICS</b> | Service Voltage RMS <sup>1)</sup>                  | 460V  | 660V  | 200V  | 200V  | 100V  |
|                                   | Test Voltage AC RMS                                | 2400V   | 3000V   | 1600V   | 1600V   | 1300V   |
|                                   | Current carrying capacity                          | 20A   | 20A   | 20A   | 20A   | 15A   |
|                                   | Typical Contact Resistance                         | ≤3mΩ  |   |   |   |   |
|                                   | Insulation Resistance                              | ≥1000MΩ   |   |   |   |   |
| <b>CLIMATIC CHARACTERISTICS</b>   | Protection Class                                   | IP40  |   |   |   |   |
|                                   | Operating Temperature                              | -25 °C to +75 °C (-13°F to +167°F)  |   |   |   |   |
| <b>MECHANICAL CHARACTERISTICS</b> | Weight - EP 11 & 12 <sup>2)</sup>                  | 80g<br>(0.176lb)  | 84g<br>(0.185lb)  | 86g<br>(0.189lb)  | 86g<br>(0.189lb)  | 86g<br>(0.189lb)  |
|                                   | Weight - EP 13 & 14 <sup>2)</sup>                  | 48g<br>(0.105lb)  | 50g<br>(0.110lb)  | 54g<br>(0.119lb)  | 54g<br>(0.119lb)  | 54g<br>(0.119lb)  |
|                                   | Weight - AP 11 & 12 <sup>2)</sup>                  | N/A   | 42g<br>(0.092lb)  | 44g<br>(0.097lb)  | 44g<br>(0.097lb)  | 44g<br>(0.097lb)  |
|                                   | Weight - AP 13, 14, 21 & 22 <sup>2)</sup>          | N/A   | 26g<br>(0.057lb)  | 30g<br>(0.066lb)  | 30g<br>(0.066lb)  | 28g<br>(0.061lb)  |
|                                   | Typical Cable retention force                      | 22Kg to 44Kg (50lb to 100lb) - Dependant on cable material and diameter           |   |   |   |   |
|                                   | Mechanical operations                              | 1000 mating cycles  |   |   |   |   |

<sup>1)</sup> Not suitable for domestic applications above 50V

<sup>2)</sup> Approximate weight only, does not include packaging. Please contact us for exact weight for shipping purposes.



Rev 2 - 09/2005

## STANDARD DATA EP/AP (CONT'D)

| MATERIALS                        | TYPE             | DETAILS                          |                                 |
|----------------------------------|------------------|----------------------------------|---------------------------------|
|                                  |                  | AP                               | EP                              |
| Connector shell                  |                  | Modified PPE Resin               | Diecast Zinc Alloy              |
| Shell finish                     |                  | Black                            | Satin Nickel or Black           |
| Insulators                       |                  | UL94V-0 PBT Resin                |                                 |
| Cable Bushing                    |                  | Silicon Rubber                   | UL94 HB Thermoplastic Elastomer |
| Male contact Machined - Solder   |                  | Brass / Bright Tin               |                                 |
| Material / Plating               |                  |                                  |                                 |
| Female contact Machined - Solder |                  | Brass / Bright Tin               |                                 |
| Material / Plating               |                  |                                  |                                 |
| CLAMPING CHARACTERISTICS         | Cable OD Range   | 11mm to 17mm<br>(0.43" to 0.67") | 9mm to 16mm<br>(0.35" to 0.63") |
|                                  | Retention Method | Two opposing plastic screws      | Metal saddle clamp              |



## EP/AP SERIES PANEL CUTOUT DATA - FRONT VIEW

EP 13/AP 13/AP 21

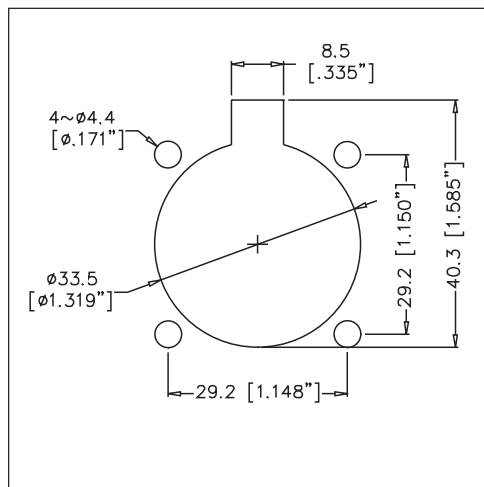

EP 14/AP 14/AP 22

