

NUMBER C-1734081
 METRIC
 3RD ANGLE PROJECTION

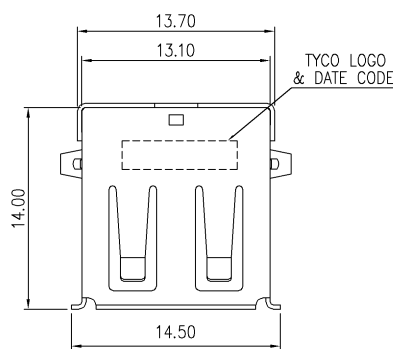

NOTE:
 1. MATERIAL:
 HOUSING: THERMOPLASTIC HIGH TEMP WITH 30%GF, UL94V-0, BLACK COLOR.
 CONTACT: PHOSPHOR BRONZE, T=0.25mm.
 SHELL: BRASS, T=0.3mm.
 BACK COVER: SPCC, T=0.3mm.
 2. FINISH:
 CONTACT: 30μ" MIN. GOLD PLATING ON CONTACT AREA, 150μ" MIN. BRIGHT TIN PLATING ON SOLDERTAILS, 50μ" MIN. NICKEL UNDERPLATING OVERALL.
 SHELL: 120μ" MIN. NICKEL PLATED OVER 100μ" MIN. Cu UNDERPLATING OVERALL.
 BACK COVER: 120μ" MIN. NICKEL PLATED.
 3. REFLOW SOLDER CAPABLE TO 260°C PER TYCO SPEC 109-201, CONDITION B.

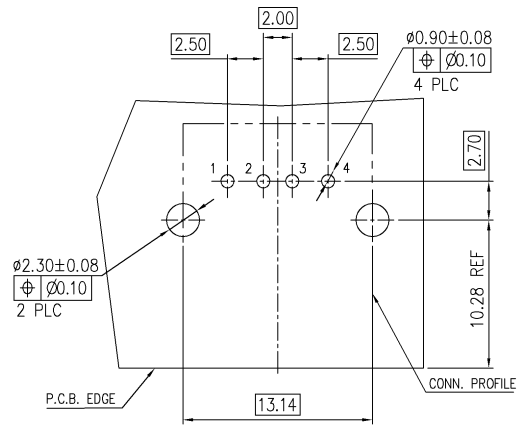

RECOMMEND P.C.B LAYOUT (THICKNESS=1.6mm)
 (COMPONENT SIDE) TOLERANCE±0.05

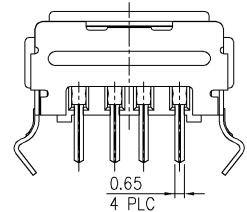
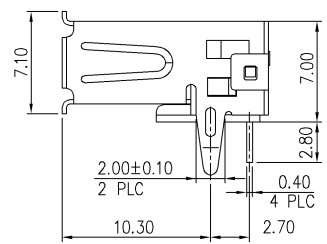
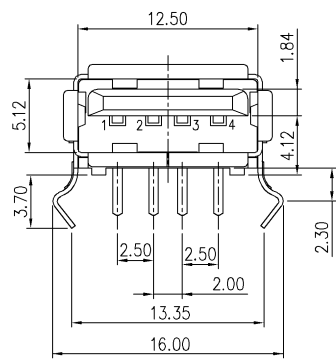

THIS INFORMATION IS CONFIDENTIAL AND IS DISCLOSED TO YOU ON CONDITION THAT NO FURTHER DISCLOSURE IS MADE BY YOU TO OTHER THAN AMP PERSONNEL WITHOUT DIMENSIONS IN MILLIMETERS. DO NOT SCALE PRINT.

PRINT DIST DW

B	ADD P/Ns	ECR-06-001878	OH	27JAN
A	ADD P/Ns	ECR-05-006892	SH	2006
O	FIRST RELEASED	FZ00-0202-04	OH	29JUL
LTR	REVISION RECORD	ECN	SH	2005
			DWN	30SEP
			CHK	2004
			DATE	

TOLERANCES UNLESS OTHERWISE SPECIFIED:	DWN	O. HU	tyco	TYCO HOLDINGS (BERMUDA)
0 PLC ±	24-JAN-2006	S. HOU	Electronics	VII LTD. TAIWAN BRANCH
1 PLC ±0.35		24-JAN-2006	NAME	
2 PLC ±0.25				
3 PLC ±				
ANGLES ±				
MATERIAL	APVD	W.J. KE	USB CONNECTOR, RECEPTACLE	
SEE NOTE	PRODUCT SPEC	24-JAN-2006	4 POSITION, SERIES A	
	108-57505		LOC	SIZE
FINISH	QUALIFICATION TEST REPORT	501-57579	DW	A ₃
SEE NOTE	WEIGHT	2.01 gram	SCALE	
				DRAWING NO
				C-1734081
				REV
				B
				SHEET
				1 OF 14

CUSTOMER DRAWING

NUMBER C-1734081
 METRIC
 3RD ANGLE PROJECTION

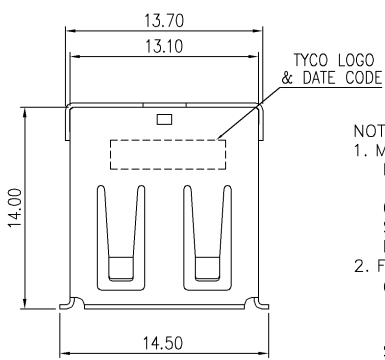

NOTE:
 1. MATERIAL:
 HOUSING: THERMOPLASTIC HIGH TEMP WITH 30%GF, UL94V-0, COLOR: SEE TABLE.
 CONTACT: PHOSPHOR BRONZE, T=0.25mm.
 SHELL: BRASS, T=0.3mm.
 BACK COVER: SPCC, T=0.3mm.
 2. FINISH:
 CONTACT: 30μ" MIN. GOLD PLATING ON CONTACT AREA, 150μ" MIN. BRIGHT TIN PLATING ON SOLDER TAILS.
 50μ" MIN. NICKEL UNDERPLATING OVERALL.
 SHELL: 120μ" MIN. NICKEL PLATED OVER 100m" MIN. Cu UNDERPLATING OVERALL.
 BACK COVER: 120μ" MIN. NICKEL PLATED.
 3. REFLOW SOLDER CAPABLE TO 260°C PER TYCO SPEC 109-201, CONDITION B.

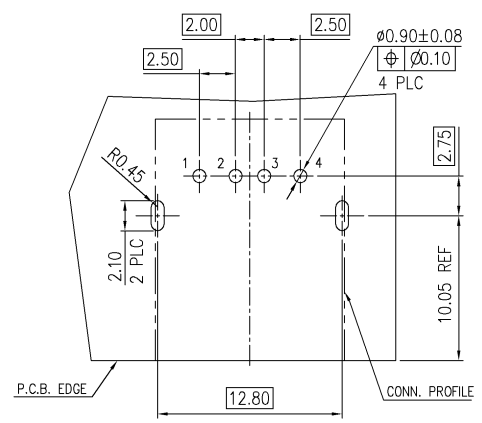

RECOMMEND P.C.B LAYOUT (THICKNESS=1.6mm)
 (COMPONENT SIDE) TOLERANCE±0.05

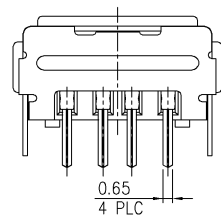
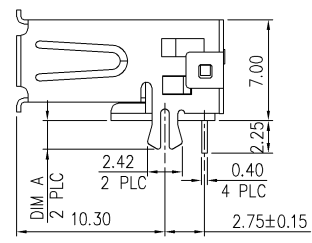
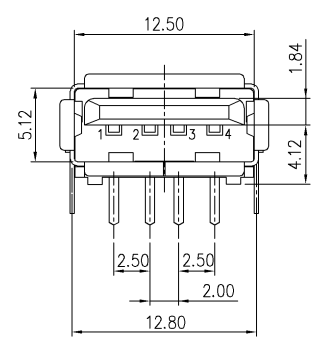

MOON GRAY	2.0	TAPE & REEL	1-1734081-4
BLACK	2.4	TAPE & REEL	1-1734081-3
BLACK	2.0	TAPE & REEL	1-1734081-2
		TRAY	1-1734081-1
HSG. COLOR	DIM A	PACKAGE	PART NUMBER

TOLERANCES UNLESS OTHERWISE SPECIFIED: 0 PLC ± 1 PLC ±0.35 2 PLC ±0.25 3 PLC ± ANGLES ±	DWN O. HU 24-JAN-2006	TYCO HOLDINGS (BERMUDA) VII LTD. TAIWAN BRANCH
	CHK S. HOU 24-JAN-2006	
MATERIAL SEE NOTE	APVD W.J. KE 24-JAN-2006	NAME USB CONNECTOR, RECEPTACLE 4 POSITION, SERIES A
FINISH SEE NOTE	QUALIFICATION TEST REPORT 501-57579	LOC DW
	WEIGHT 2.01 gram	SIZE A ₃
		DRAWING NO C-1734081
		REV B
		SCALE --
		SHEET 2 OF 14

SEE SHEET 1.				
LTR	REVISION RECORD	ECN	DWN/CHK	DATE

THIS INFORMATION IS CONFIDENTIAL AND IS DISCLOSED TO YOU ON CONDITION THAT NO FURTHER DISCLOSURE IS MADE BY YOU TO OTHER THAN AMP PERSONNEL WITHOUT DIMENSIONS IN MILLIMETERS. DO NOT SCALE PRINT.

8 7 6 5 4 3 2 1
 CUSTOMER DRAWING

NUMBER C-1734081
METRIC
3RD ANGLE PROJECTION

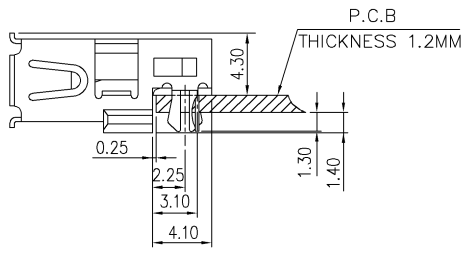
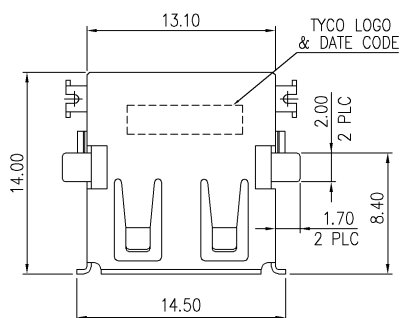

RECOMMENDED MOUNT DIMENSION

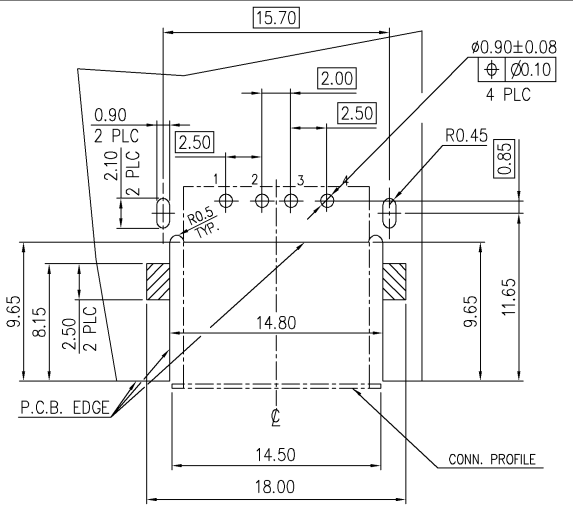

RECOMMEND P.C.B LAYOUT (THICKNESS=1.2mm)
(COMPONENT SIDE) TOLERANCE±0.05

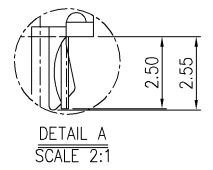
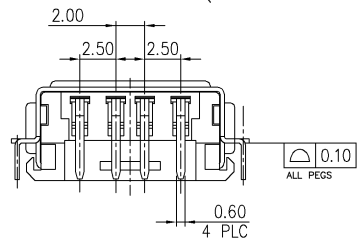
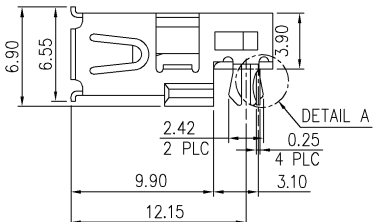
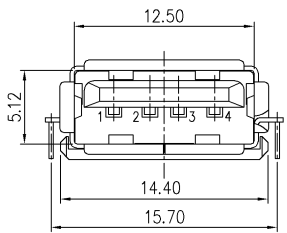

- NOTE:
1. MATERIAL:
HOUSING: THERMOPLASTIC HIGH TEMP WITH 30%GF, UL94V-0, BLACK COLOR.
CONTACT: PHOSPHOR BRONZE, T=0.25mm.
SHELL: BRASS, T=0.3mm.
2. FINISH:
CONTACT: 30μ" MIN. GOLD PLATING ON CONTACT AREA, 150μ" MIN. BRIGHT TIN PLATING ON SOLDERTAILS. 50μ" MIN. NICKEL UNDERPLATING OVERALL.
SHELL: 120μ" MIN. NICKEL PLATED OVER 100μ" MIN. Cu UNDERPLATING OVERALL.
3. REFLOW SOLDER CAPABLE TO 260°C PER TYCO SPEC 109-201, CONDITION B.

SEE SHEET 1.	ECN	DWN/CHK	DATE
LTR	REVISION RECORD		

TOLERANCES UNLESS OTHERWISE SPECIFIED:	DWN	O. HU	24-JAN-2006	TYCO HOLDINGS (BERMUDA) VII LTD. TAIWAN BRANCH NAME
0 PLC ±	CHK	S. HOU	24-JAN-2006	
1 PLC ±0.35		W.J. KE	24-JAN-2006	USB CONNECTOR, RECEPTACLE 4 POSITION, SERIES A NAME
2 PLC ±0.25				
3 PLC ±				LOC SIZE DRAWING NO DW A ₃ C-1734081 SCALE SHEET 3 OF 14
ANGLES ±				
MATERIAL	APVD			
SEE NOTE	PRODUCT SPEC			
	108-57505			
FINISH	QUALIFICATION TEST REPORT			
SEE NOTE	501-57579			
	WEIGHT			
	1.57 gram			

8 7 6 5 4 3 2 1 CUSTOMER DRAWING

THIS INFORMATION IS CONFIDENTIAL AND IS DISCLOSED TO YOU ON CONDITION THAT NO FURTHER DISCLOSURE IS MADE BY YOU TO OTHER THAN AMP PERSONNEL WITHOUT DIMENSIONS IN MILLIMETERS. DO NOT SCALE PRINT.

NUMBER C-1734081
 METRIC
 3RD ANGLE PROJECTION

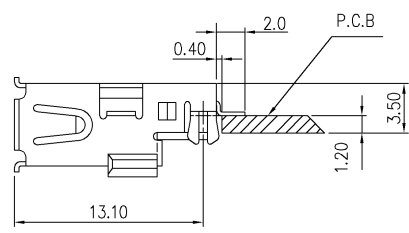
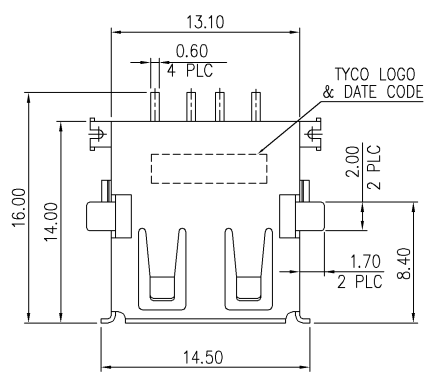

RECOMMENDED MOUNT DIMENSION

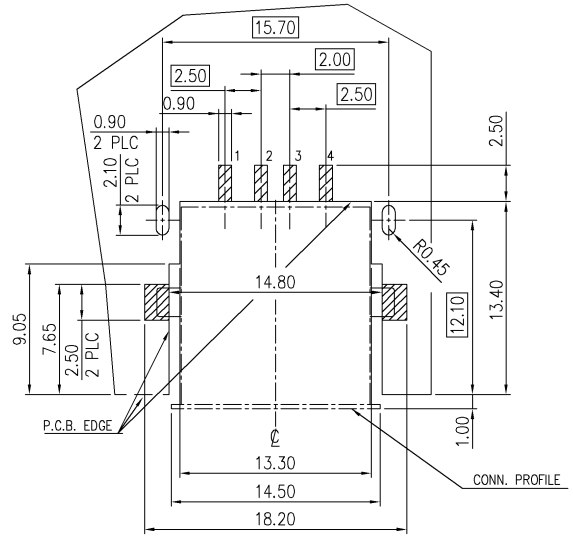

RECOMMEND P.C.B LAYOUT (THICKNESS=1.2mm)
 (COMPONENT SIDE) TOLERANCE±0.05

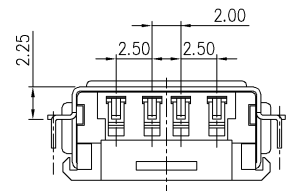
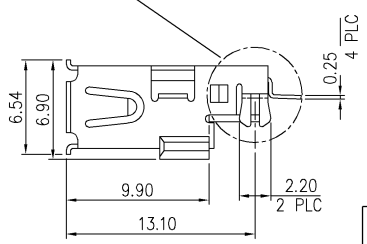
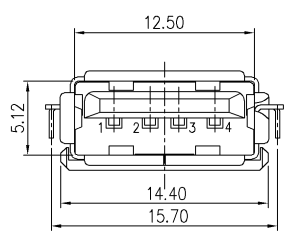
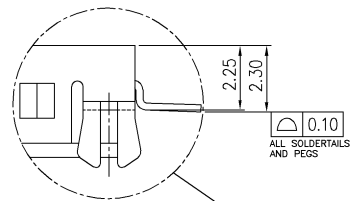

TAPE & REEL	3-1734081-1
PACKAGE	PART NUMBER

tyco TYCO HOLDINGS (BERMUDA)
Electronics VII LTD. TAIWAN BRANCH

TOLERANCES UNLESS OTHERWISE SPECIFIED:	DWN	O. HU
0 PLC	±0.35	24-JAN-2006
1 PLC	±0.35	S. HOU
2 PLC	±0.25	24-JAN-2006
3 PLC	±0.25	
ANGLES	±	
MATERIAL	APVD	W.J. KE
SEE NOTE	PRODUCT SPEC	24-JAN-2006
	108-57505	
FINISH	QUALIFICATION TEST REPORT	
SEE NOTE	501-57579	
	WEIGHT	
	1.50 gram	

USB CONNECTOR, RECEPTACLE
 4 POSITION, SERIES A

LOC	SIZE	DRAWING NO	REV
DW	A ₃	C-1734081	B
SCALE	SHEET		
--	4 OF 14		

- NOTE:
- MATERIAL:
 HOUSING: THERMOPLASTIC HIGH TEMP WITH 30X0F, UL94V-0, BLACK COLOR.
 CONTACT: PHOSPHOR BRONZE, T=0.25mm.
 SHELL: BRASS, T=0.3mm.
 - FINISH:
 CONTACT: 30µ MIN. GOLD PLATING ON CONTACT AREA,
 150µ MIN. BRIGHT TIN PLATING ON SOLDER TAILS.
 50µ MIN. NICKEL UNDERPLATING OVERALL.
 SHELL: 120µ MIN. NICKEL PLATED OVER 100µ MIN. Cu UNDERPLATING OVERALL.
 - REFLOW SOLDER CAPABLE TO 260°C PER TYCO SPEC 109-201, CONDITION B.

SEE SHEET 1.	ECN	DWN/CHK	DATE
LTR	REVISION RECORD		

CUSTOMER DRAWING

THIS INFORMATION IS CONFIDENTIAL AND IS DISCLOSED TO YOU ON CONDITION THAT NO FURTHER DISCLOSURE IS MADE BY YOU TO OTHER THAN AMP PERSONNEL WITHOUT THE WRITTEN PERMISSION OF AMP. DIMENSIONS IN MILLIMETERS. DO NOT SCALE PRINT.

PRINT DIST DW

8 7 6 5 4 3 2 1

D
 C
 B
 A

NUMBER C-1734081
 METRIC
 3RD ANGLE PROJECTION

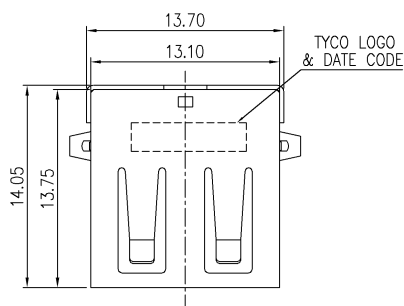

NOTE:
 1. MATERIAL:
 HOUSING: THERMOPLASTIC WITH 30%GF, UL94V-0, BLACK COLOR.
 CONTACT: PHOSPHOR BRONZE, T=0.25mm.
 SHELL: BRASS, T=0.3mm.
 BACK COVER: SPCC, T=0.3mm.
 2. FINISH:
 CONTACT: 30μm MIN. GOLD PLATING ON CONTACT AREA,
 150μm MIN. BRIGHT TIN PLATING ON SOLDER TAILS.
 50μm MIN. NICKEL UNDERPLATING OVERALL.
 SHELL: 120μm MIN. NICKEL PLATED OVER 100μm MIN. Cu
 UNDERPLATING OVERALL.
 BACK COVER: 120μm MIN. NICKEL PLATED.
 3. REFLOW SOLDER CAPABLE TO 260°C PER TYCO
 SPEC 109-201, CONDITION B.

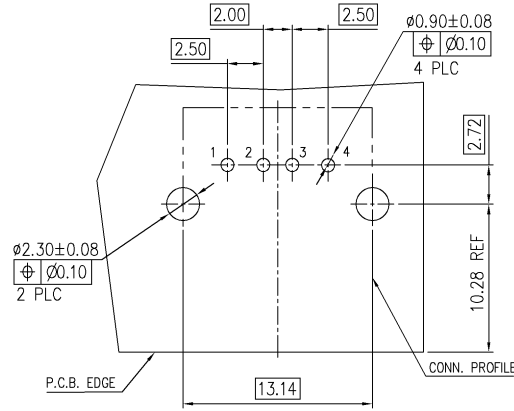

RECOMMEND P.C.B LAYOUT (THICKNESS=1.6mm)
 (COMPONENT SIDE) TOLERANCE±0.05

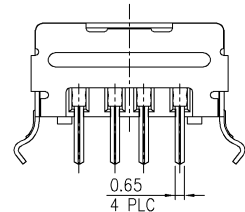
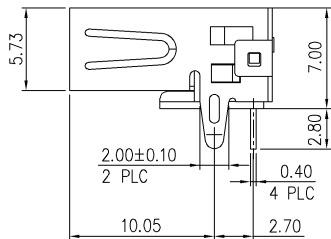
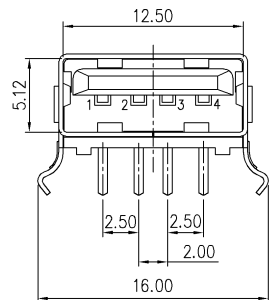

THIS INFORMATION IS CONFIDENTIAL AND IS DISCLOSED TO YOU ON CONDITION THAT
 NO FURTHER DISCLOSURE IS MADE BY YOU TO OTHER THAN AMP PERSONNEL WITHOUT
 THE WRITTEN PERMISSION OF AMP. DIMENSIONS IN MILLIMETERS. DO NOT SCALE PRINT.

TRAY	MOON GRAY	4-1734081-2
	NONMETALLIC PEARL	4-1734081-1
PACKAGE	HSG. COLOR	PART NUMBER

TOLERANCES UNLESS OTHERWISE SPECIFIED: 0 PLC ± 1 PLC ±0.35 2 PLC ±0.25 3 PLC ± ANGLES ±	DWN	O. HU 24-JAN-2006	TYCO HOLDINGS (BERMUDA) VII LTD. TAIWAN BRANCH
	CHK	S. HOU 24-JAN-2006	
MATERIAL	APVD	W.J. KE 24-JAN-2006	USB CONNECTOR, RECEPTACLE 4 POSITION, SERIES A
SEE NOTE	PRODUCT SPEC	108-57505	
FINISH	QUALIFICATION TEST REPORT	501-57579	LOC DW
SEE NOTE	WEIGHT	2.03 gram	SIZE A ₃
			DRAWING NO C-1734081
			REV B
			SCALE --
			SHEET 5 OF 14

SEE SHEET 1.	ECN	DWN/CHK	DATE
LTR	REVISION RECORD		

8 1 7 1 6 5 4 3 2 1
 CUSTOMER DRAWING

NUMBER C-1734081
METRIC
3RD ANGLE PROJECTION

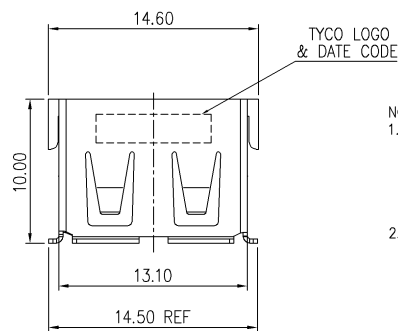

NOTE:
 1. MATERIAL:
 HOUSING: THERMOPLASTIC HIGH TEMP WITH 30%GF, UL94V-0, BLACK COLOR.
 CONTACT: PHOSPHOR BRONZE, T=0.25mm.
 SHELL: BRASS, T=0.3mm.
 BACK COVER: SPCC, T=0.3mm.
 2. FINISH:
 CONTACT: 30μ" MIN. GOLD PLATING ON CONTACT AREA, 150μ" MIN. BRIGHT TIN PLATING ON SOLDERTAILS.
 50μ" MIN. NICKEL UNDERPLATING OVERALL.
 SHELL: 120μ" MIN. NICKEL PLATED OVER 100μ" MIN. Cu UNDERPLATING OVERALL.
 BACK COVER: 120μ" MIN. NICKEL PLATED.
 3. REFLOW SOLDER CAPABLE TO 260°C PER TYCO SPEC 109-201, CONDITION B.

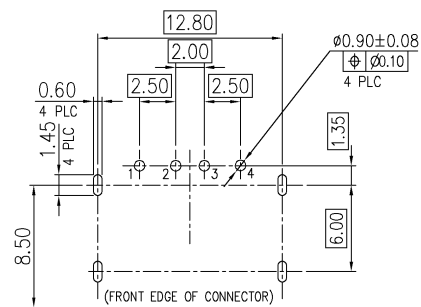

RECOMMEND P.C.B LAYOUT (THICKNESS=1.4mm)
 (COMPONENT SIDE) TOLERANCE±0.05

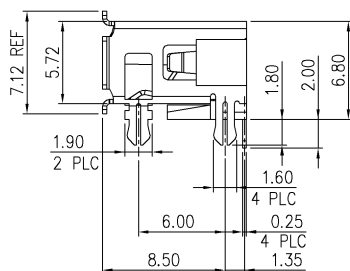
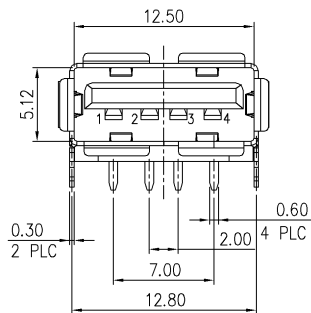

THIS INFORMATION IS CONFIDENTIAL AND IS DISCLOSED TO YOU ON CONDITION THAT NO FURTHER DISCLOSURE IS MADE BY YOU TO OTHER THAN AMP PERSONNEL WITHOUT DIMENSIONS IN MILLIMETERS. DO NOT SCALE PRINT.

PRINT DIST DW

SEE SHEET 1.	ECN	DWN/CHK	DATE
LTR	REVISION RECORD		

TOLERANCES UNLESS OTHERWISE SPECIFIED:		DWN	O. HU	tyco		TYCO HOLDINGS (BERMUDA)
0 PLC ±		24-JAN-2006	S. HOU	Electronics		VII LTD. TAIWAN BRANCH
1 PLC ±0.35			24-JAN-2006	NAME		
2 PLC ±0.25				PRODUCT SPEC		USB CONNECTOR, RECEPTACLE
3 PLC ±				108-57505		4 POSITION, SERIES A
ANGLES ±				QUALIFICATION TEST REPORT		LOC SIZE DRAWING NO
				501-57579		DW A ₃ C-1734081
				WEIGHT		SCALE SHEET
				1.54 gram		-- 6 OF 14

TAPE & REEL 5-1734081-1

PACKAGE PART NUMBER

TYCO HOLDINGS (BERMUDA) VII LTD. TAIWAN BRANCH

NAME

USB CONNECTOR, RECEPTACLE 4 POSITION, SERIES A

LOC SIZE DRAWING NO

DW A₃ C-1734081

SCALE SHEET

-- 6 OF 14

CUSTOMER DRAWING

8 7 6 5 4 3 2 1

NUMBER C-1734081
METRIC
3RD ANGLE PROJECTION

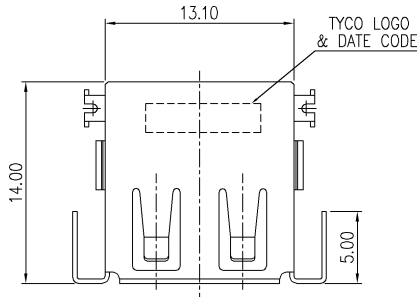

NOTE:
 1. MATERIAL:
 HOUSING: THERMOPLASTIC HIGH TEMP WITH 30%GF,
 UL94V-0, BLACK COLOR.
 CONTACT: PHOSPHOR BRONZE, T=0.25mm.
 SHELL: BRASS, T=0.3mm.
 2. FINISH:
 CONTACT: 30μ" MIN. GOLD PLATING ON CONTACT AREA,
 150μ" MIN. BRIGHT TIN PLATING ON SOLDER TAILS.
 50μ" MIN. NICKEL UNDERPLATING OVERALL.
 SHELL: 120μ" MIN. NICKEL PLATED OVER 100μ" MIN. Cu
 UNDERPLATING OVERALL.
 3. REFLOW SOLDER CAPABLE TO 260°C PER TYCO
 SPEC 109-201, CONDITION B.

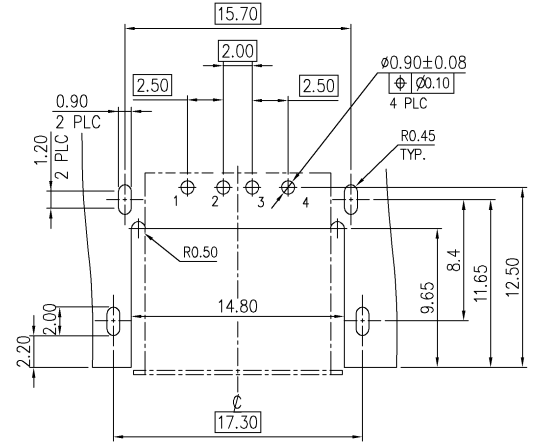

RECOMMEND P.C.B LAYOUT (THICKNESS=1.6mm)
 (COMPONENT SIDE) TOLERANCE±0.05

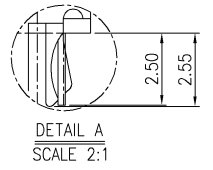
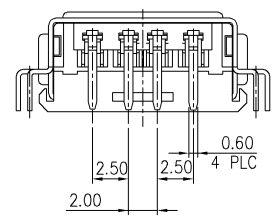
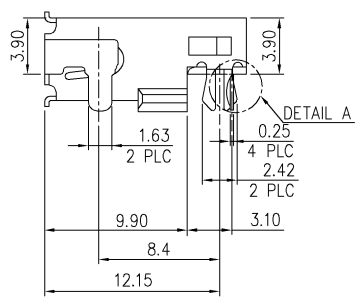
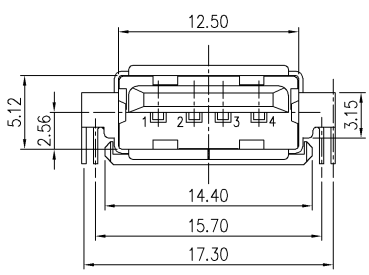

TAPE & REEL	6-1734081-2
TUBE	6-1734081-1
PACKAGE	PART NUMBER

TOLERANCES UNLESS OTHERWISE SPECIFIED: 0 PLC ± 1 PLC ±0.35 2 PLC ±0.25 3 PLC ± ANGLES ±	DWN	O. HU	tyco Electronics TYCO HOLDINGS (BERMUDA) VII LTD. TAIWAN BRANCH		
	CHK	S. HOU			
MATERIAL	APVD	W.J. KE	NAME USB CONNECTOR, RECEPTACLE 4 POSITION, SERIES A		
	PRODUCT SPEC	24-JAN-2006			
FINISH	QUALIFICATION TEST REPORT	LOC	SIZE	DRAWING NO	REV
	WEIGHT	501-57579	SCALE	A ₃	C-1734081
	1.47 gram				SHEET
					7 OF 14

SEE SHEET 1.				
LTR	REVISION RECORD	ECN	DWN/CHK	DATE

THIS INFORMATION IS CONFIDENTIAL AND IS DISCLOSED TO YOU ON CONDITION THAT NO FURTHER DISCLOSURE IS MADE BY YOU TO OTHER THAN AMP PERSONNEL WITHOUT DIMENSIONS IN MILLIMETERS. DO NOT SCALE PRINT.

8 7 6 5 4 3 2 1 CUSTOMER DRAWING

D
C
B
A

NUMBER C-1734081
METRIC
3RD ANGLE PROJECTION

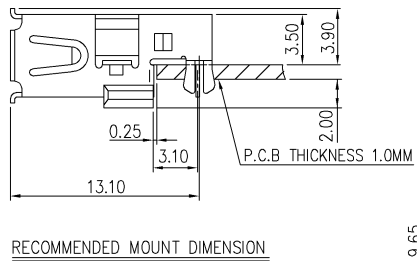
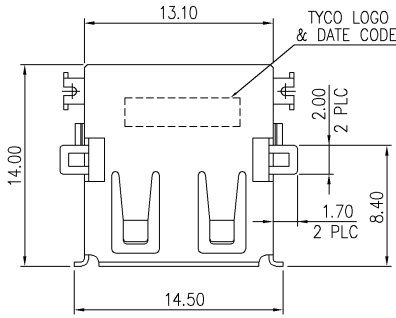

RECOMMENDED MOUNT DIMENSION

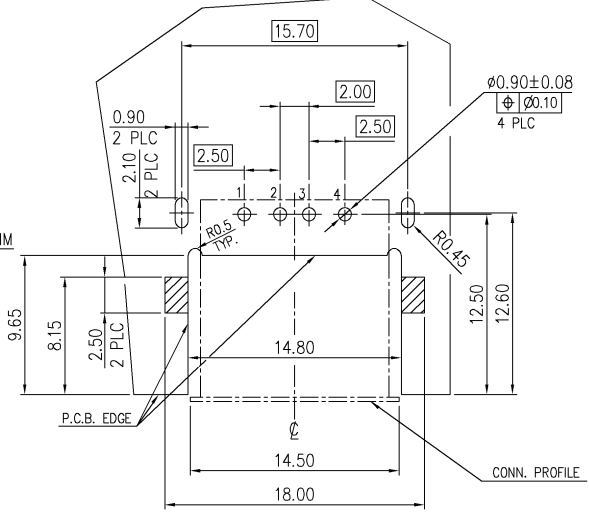

RECOMMEND P.C.B LAYOUT (THICKNESS=1.0mm)
(COMPONENT SIDE) TOLERANCE±0.05

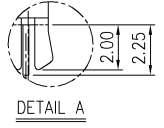
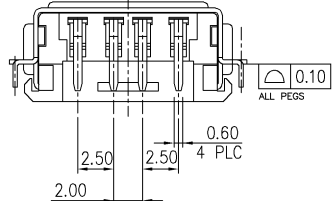
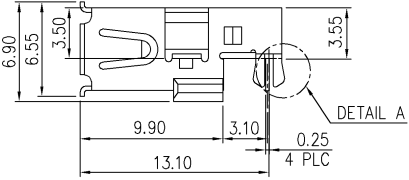
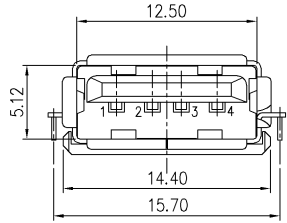

NOTE:
1. MATERIAL:
HOUSING: THERMOPLASTIC HIGH TEMP WITH 30%GF,
UL94V-0, BLACK COLOR.
CONTACT: PHOSPHOR BRONZE, T=0.25mm.
SHELL: BRASS, T=0.3mm.
2. FINISH:
CONTACT: 30μ" MIN. GOLD PLATING ON CONTACT AREA,
150μ" MIN. BRIGHT TIN PLATING ON SOLDERTAILS.
50μ" MIN. NICKEL UNDERPLATING OVERALL.
SHELL: 120μ" MIN. NICKEL PLATED OVER 100μ" MIN. Cu
UNDERPLATING OVERALL.
3. REFLOW SOLDER CAPABLE TO 260°C PER TYCO
SPEC 109-201, CONDITION B.

SEE SHEET 1.	ECN	DWN/CHK	DATE
LTR	REVISION RECORD		

TOLERANCES UNLESS OTHERWISE SPECIFIED:		DWN	O. HU	TYCO	
0 PLC	±	24-JAN-2006	S. HOU	TYCO HOLDINGS (BERMUDA)	
1 PLC	±0.35		24-JAN-2006	VII LTD. TAIWAN BRANCH	
2 PLC	±0.25			NAME	
3 PLC	±			USB CONNECTOR, RECEPTACLE	
ANGLES	±			4 POSITION, SERIES A	
MATERIAL	SEE NOTE	APVD	W.J. KE	LOC	SIZE
FINISH	SEE NOTE	PRODUCT SPEC	24-JAN-2006	DW	A ₃
		QUALIFICATION TEST REPORT	501-57579	DRAWING NO	C-1734081
		WEIGHT	1.54 gram	REV	B
				SCALE	--
				SHEET	8 OF 14

CUSTOMER DRAWING

THIS INFORMATION IS CONFIDENTIAL AND IS DISCLOSED TO YOU ON CONDITION THAT NO FURTHER DISCLOSURE IS MADE BY YOU TO OTHER THAN AMP PERSONNEL WITHOUT DIMENSIONS IN MILLIMETERS. DO NOT SCALE PRINT.

8 7 6 5 4 3 2 1

NUMBER C-1734081
 3RD ANGLE PROJECTION
 METRIC

NOTES:

1. MATERIAL:
 TRAY: PE.
 POLYLONE:POLYLONE
 SHIPPING CARTON: CORRUGATED FIBER.
2. DIMENSION :
 TUBE : L=370mm, W=21.8mm, H=8.6mm
 SHIPPING CARTON : L=390mm, W=165mm, H=90mm
3. QUANTITY :
 25 PCS/TUBE
 49 TUBS/INNER BOX(1,225PCS)
4. WEIGHT :
 NET WEIGHT : 1.80 KG
 GROSS WEIGHT : 3.70 KG

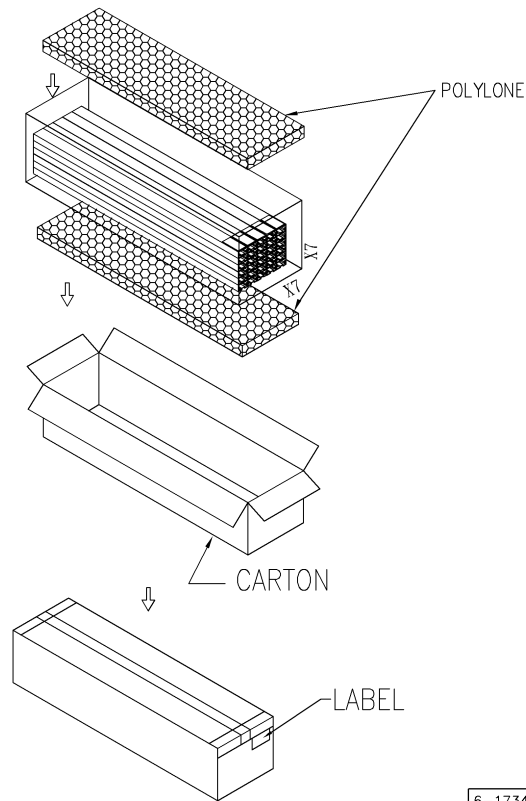
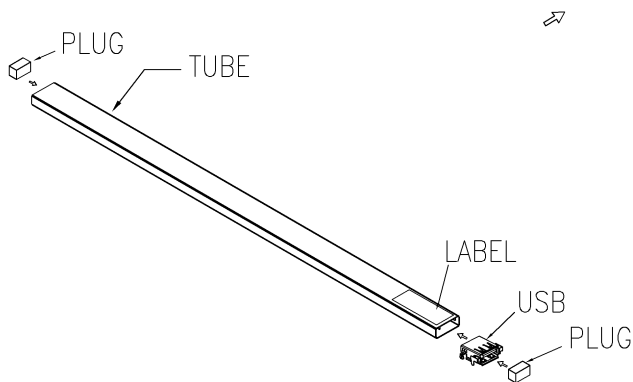

THIS INFORMATION IS CONFIDENTIAL AND IS DISCLOSED TO YOU ON CONDITION THAT
 NO FURTHER DISCLOSURE IS MADE BY YOU TO OTHER THAN AMP PERSONNEL WITHOUT
 DIMENSIONS IN MILLIMETERS. DO NOT SCALE PRINT.

PRINT DIST
 DW

SEE SHEET 1.	ECN	DWN/CHK	DATE
LTR	REVISION RECORD		

TOLERANCES UNLESS OTHERWISE SPECIFIED:		DWN	O. HU	TYCO HOLDINGS (BERMUDA) VII LTD. TAIWAN BRANCH	
0 PLC ±	1 PLC ±	24-JAN-2006	S. HOU	NAME	
2 PLC ±	3 PLC ±	24-JAN-2006	W.J. KE	USB CONNECTOR, RECEPTACLE 4 POSITION, SERIES A	
MATERIAL		APVD	24-JAN-2006	LOC	SIZE
SEE NOTE		PRODUCT SPEC		DW	A ₃
FINISH		APPLICATION SPEC		DRAWING NO	REV
SEE NOTE		WEIGHT		C-1734081	B
				SCALE	SHEET
				--	9 OF 14

6-1734081-1
 PART NUMBER

CUSTOMER DRAWING

NUMBER C-1734081
METRIC
3RD ANGLE PROJECTION

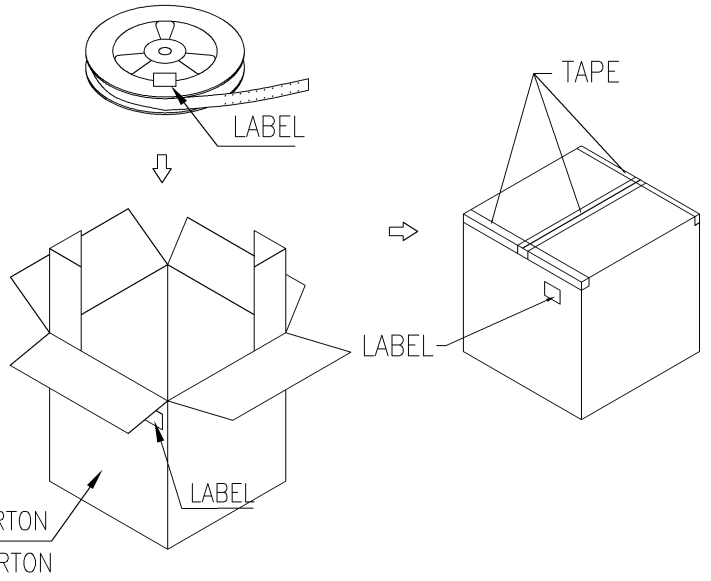
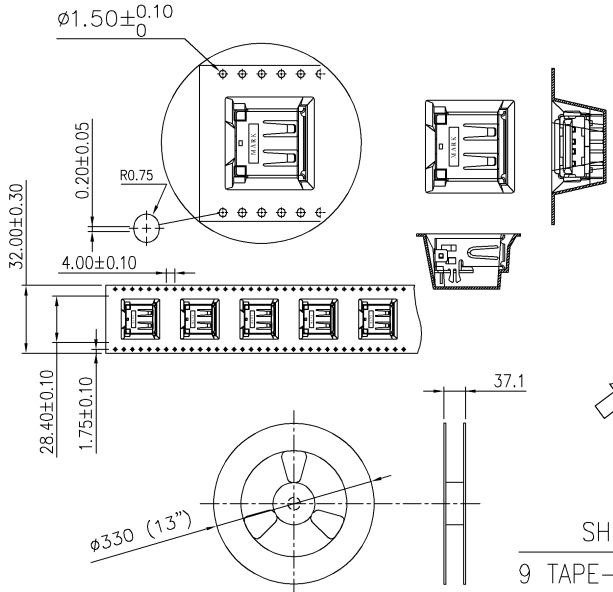

- NOTES:
- MATERIAL:
REEL: PS.
EMBOSSED CARRIER: PS.
COVER TAPE: PBT.
 - DIMENSION :
TAPE REEL: $\phi 330\text{mm} \times 37.1\text{mm}$
SHIPPING CARTON: L=350mm, W=350mm, H=350mm
 - QUANTITY :
PRIMARY PACKING: (SEE TABLE) PCS/REEL
SECONDARY PACKING: 9 REELS/CARTON.
 - WEIGHT :
NET WEIGHT: (SEE TABLE) .
GROSS WEIGHT: (SEE TABLE) .
 - PEELING RESISTANCE: 20G TO 130G.
 - PEELING SPEED: 300MM/MIN.

9.85 kg	4.85 kg	3150	350	7-1734081-1
				3-1734081-1
9.68 kg	4.52 kg	2250	250	1-1734081-4
				1-1734081-3
				1-1734081-2
GROSS WEIGHT/ CARTON	NET WEIGHT/ CARTON	USB/ CARTON	PCS/ TAPE & REEL	PART NUMBER

TOLERANCES UNLESS OTHERWISE SPECIFIED:		DWN	O. HU	TYCO HOLDINGS (BERMUDA)	
0	PLC	±	24-JAN-2006	VII LTD. TAIWAN BRANCH	
1	PLC	±		NAME	
2	PLC	±	CHK	S. HOU	
3	PLC	±		24-JAN-2006	
ANGLES		±			
MATERIAL	APVD	W.J. KE	USB CONNECTOR, RECEPTACLE		
SEE NOTE	PRODUCT SPEC	24-JAN-2006	4 POSITION, SERIES A		
FINISH	APPLICATION SPEC		LOC	SIZE	DRAWING NO
SEE NOTE	WEIGHT		DW	A ₃	C-1734081
			SCALE		REV B
					10 OF 14

SEE SHEET 1.				
LTR	REVISION RECORD	ECN	DWN/CHK	DATE

THIS INFORMATION IS CONFIDENTIAL AND IS DISCLOSED TO YOU ON CONDITION THAT NO FURTHER DISCLOSURE IS MADE BY YOU TO OTHER THAN AMP PERSONNEL WITHOUT DIMENSIONS IN MILLIMETERS. DO NOT SCALE PRINT.

8 7 6 5 4 3 2 1 CUSTOMER DRAWING

D
C
B
A

NUMBER C-1734081
 3RD ANGLE PROJECTION
 METRIC

NOTES:

1. MATERIAL:
 TRAY: PE.
 POLYLONE:POLYLONE
 SHIPPING CARTON: CORRUGATED FIBER.
2. DIMENSION :
 TUBE : L=370mm, W=18.7mm, H=10.1mm
 SHIPPING CARTON : L=390mm, W=165mm, H=90mm
3. QUANTITY :
 25 PCS/TUBE
 40 TUBS/INNER BOX(1,000PCS)
4. WEIGHT :
 NET WEIGHT : 1.54 KG
 GROSS WEIGHT : 2.45 KG

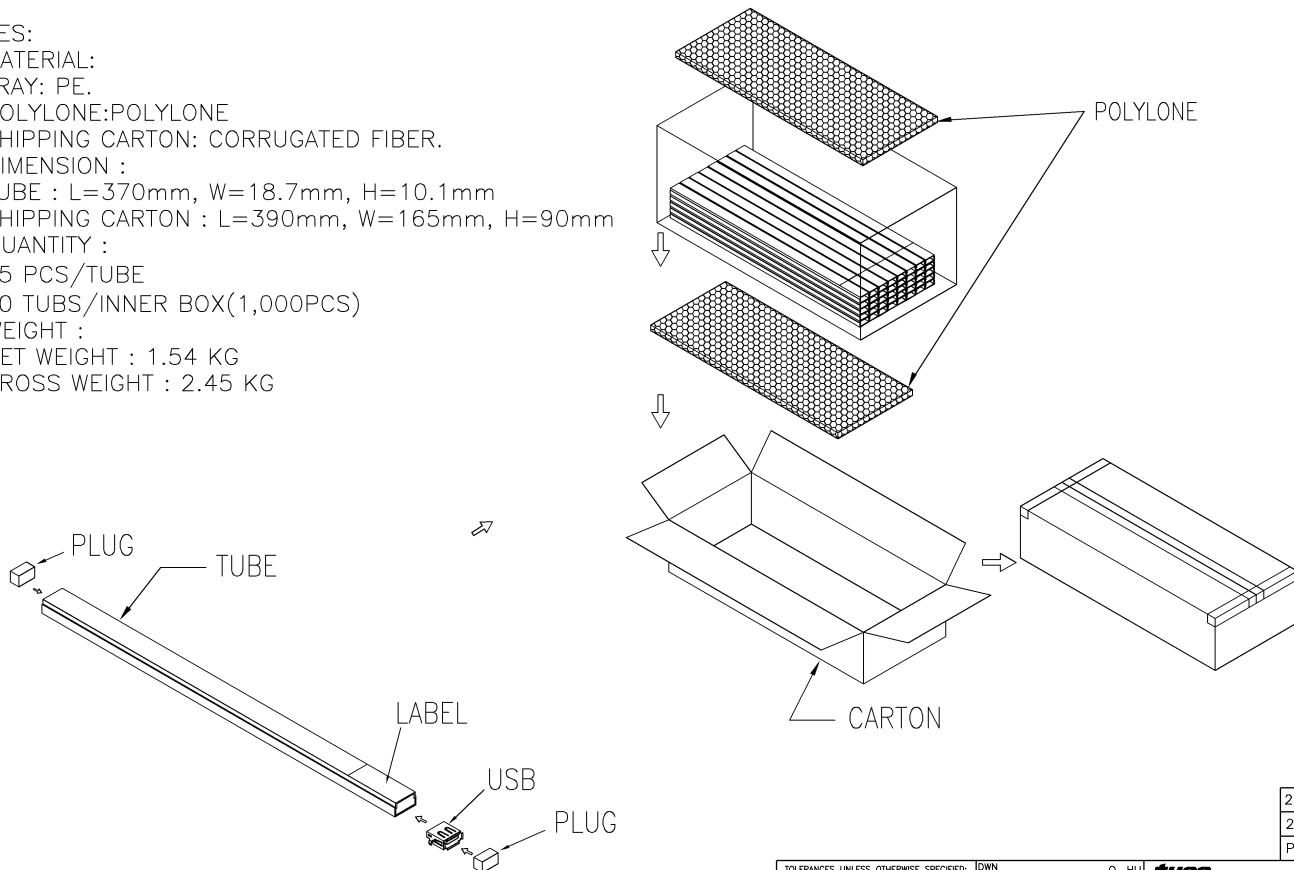

THIS INFORMATION IS CONFIDENTIAL AND IS DISCLOSED TO YOU ON CONDITION THAT
 NO FURTHER DISCLOSURE IS MADE BY YOU TO OTHER THAN AMP PERSONNEL WITHOUT
 DIMENSIONS IN MILLIMETERS. DO NOT SCALE PRINT.

2-1734081-2
 2-1734081-1
 PART NUMBER

TOLERANCES UNLESS OTHERWISE SPECIFIED:		DWN	O. HU	tyco TYCO HOLDINGS (BERMUDA)	
0	PLC ±	24-JAN-2006	24-JAN-2006	VII LTD. TAIWAN BRANCH	
1	PLC ±	CHK	S. HOU	NAME	
2	PLC ±		24-JAN-2006	APVD	
3	PLC ±			W.J. KE	
ANGLES ±				24-JAN-2006	
MATERIAL		PRODUCT SPEC		USB CONNECTOR, RECEPTACLE	
SEE NOTE		APPLICATION SPEC		4 POSITION, SERIES A	
FINISH		WEIGHT		LOC	SIZE
SEE NOTE				DW	A ₃
				DRAWING NO	C-1734081
				SCALE	11 OF 14
				SHEET	

SEE SHEET 1.	ECN	DWN	CHK	DATE
LTR	REVISION RECORD			

8 7 6 5 4 3 2 1 CUSTOMER DRAWING

NUMBER C-1734081
 3RD ANGLE PROJECTION
 METRIC

THIS INFORMATION IS CONFIDENTIAL AND IS DISCLOSED TO YOU ON CONDITION THAT NO FURTHER DISCLOSURE IS MADE BY YOU TO OTHER THAN AMP PERSONNEL WITHOUT DIMENSIONS IN MILLIMETERS. DO NOT SCALE PRINT.

PRINT DIST
 DW

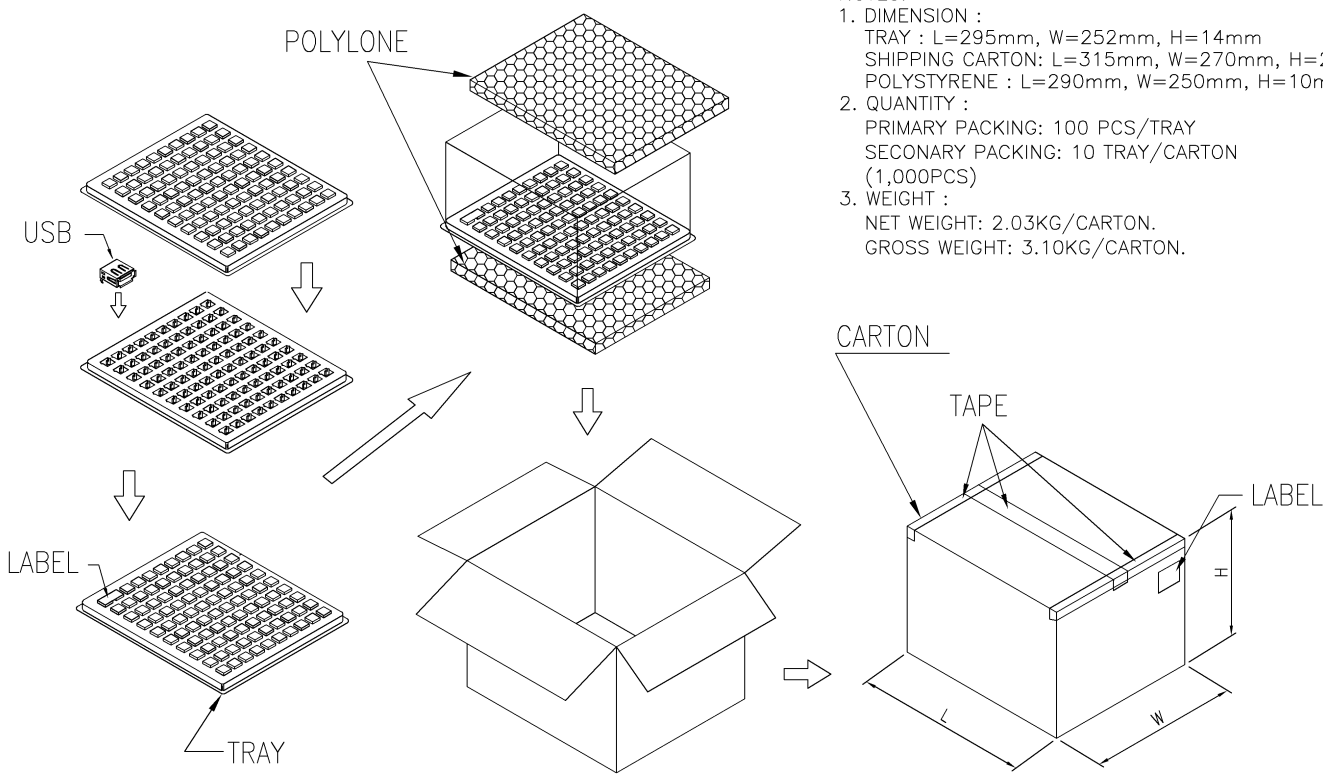

- NOTES:
- DIMENSION :
 TRAY : L=295mm, W=252mm, H=14mm
 SHIPPING CARTON: L=315mm, W=270mm, H=200mm
 POLYSTYRENE : L=290mm, W=250mm, H=10mm
 - QUANTITY :
 PRIMARY PACKING: 100 PCS/TRAY
 SECONARY PACKING: 10 TRAY/CARTON (1,000PCS)
 - WEIGHT :
 NET WEIGHT: 2.03KG/CARTON.
 GROSS WEIGHT: 3.10KG/CARTON.

4-1734081-2
4-1734081-1
1-1734081-1
1734081-1
PART NUMBER

TOLERANCES UNLESS OTHERWISE SPECIFIED: 0 PLC ± 1 PLC ± 2 PLC ± 3 PLC ± ANGLES ±	DWN	O. HU	TYCO HOLDINGS (BERMUDA) VII LTD. TAIWAN BRANCH
	CHK	S. HOU	
MATERIAL SEE NOTE	APVD	W.J. KE	USB CONNECTOR, RECEPTACLE 4 POSITION, SERIES A
	PRODUCT SPEC	24-JAN-2006	
FINISH SEE NOTE	APPLICATION SPEC		LOC
	WEIGHT		SIZE
			DRAWING NO
			REV
			SCALE
			SHEET

SEE SHEET 1.	ECN	DWN	CHK	DATE
LTR	REVISION RECORD			

8 7 6 5 4 3 2 1 CUSTOMER DRAWING

NUMBER C-1734081
3RD ANGLE PROJECTION
METRIC

PRINT DIST DW
THIS INFORMATION IS CONFIDENTIAL AND IS DISCLOSED TO YOU ON CONDITION THAT NO FURTHER DISCLOSURE IS MADE BY YOU TO OTHER THAN AMP PERSONNEL WITHOUT DIMENSIONS IN MILLIMETERS. DO NOT SCALE PRINT.

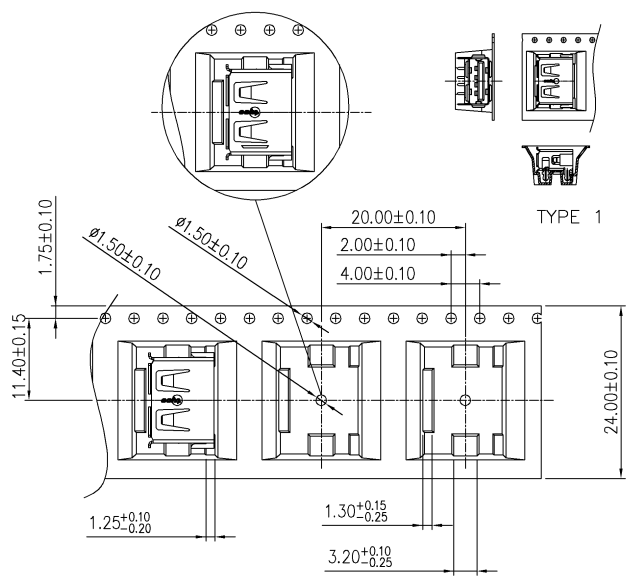

TYPE 1

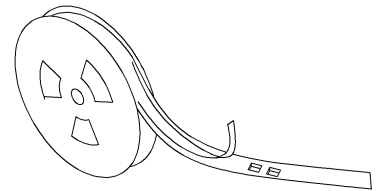
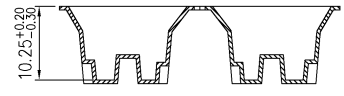

SHIPPING CARTON

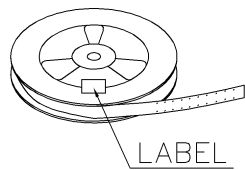

LABEL

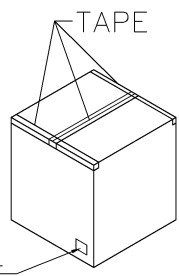

LABEL

NOTES:

1. MATERIAL:
REEL: PS.
EMBOSSED CARRIER: PS.
COVER TAPE: PBT.
2. DIMENSION :
TAPE REEL: $\phi 330\text{mm} \times 29.5\text{mm}$
SHIPPING CARTON: L=350mm, W=350mm, H=400mm
3. QUANTITY :
PRIMARY PACKING: 300PCS/REEL
SECONDARY PACKING: 12REELS/CARTON(3600PCS).
4. WEIGHT :
NET WEIGHT: 0.46 KG/REEL, 5.55 KG/CARTON.
GROSS WEIGHT: 0.89 KG/REEL, 10.65 KG/CARTON.
5. PEELING RESISTANCE: 20G TO 130G.
6. PEELING SPEED: 300MM/MIN.

SEE SHEET 1.	ECN	DWN/CHK	DATE
LTR	REVISION RECORD		

TOLERANCES UNLESS OTHERWISE SPECIFIED:		DWN	O. HU	5-1734081-1	
0	PLC	24-JAN-2006	24-JAN-2006	PART NUMBER	
1	PLC	24-JAN-2006	24-JAN-2006		
2	PLC	24-JAN-2006	24-JAN-2006		
3	PLC	24-JAN-2006	24-JAN-2006		
ANGLES		±	±		
MATERIAL	APVD	W.J. KE	TYCO Electronics		
SEE NOTE	PRODUCT SPEC	24-JAN-2006	TYCO HOLDINGS (BERMUDA) VII LTD. TAIWAN BRANCH		
FINISH	APPLICATION SPEC		NAME		
SEE NOTE	WEIGHT		USB CONNECTOR, RECEPTACLE 4 POSITION, SERIES A		
			LOC	SIZE	DRAWING NO
			DW	A ₃	C-1734081
			SCALE		REV B
					SHEET 13 OF 14

CUSTOMER DRAWING

NUMBER C-1734081
METRIC
3RD ANGLE PROJECTION

PRINT DIST DW
THIS INFORMATION IS CONFIDENTIAL AND IS DISCLOSED TO YOU ON CONDITION THAT NO FURTHER DISCLOSURE IS MADE BY YOU TO OTHER THAN AMP PERSONNEL WITHOUT DIMENSIONS IN MILLIMETERS. DO NOT SCALE PRINT.

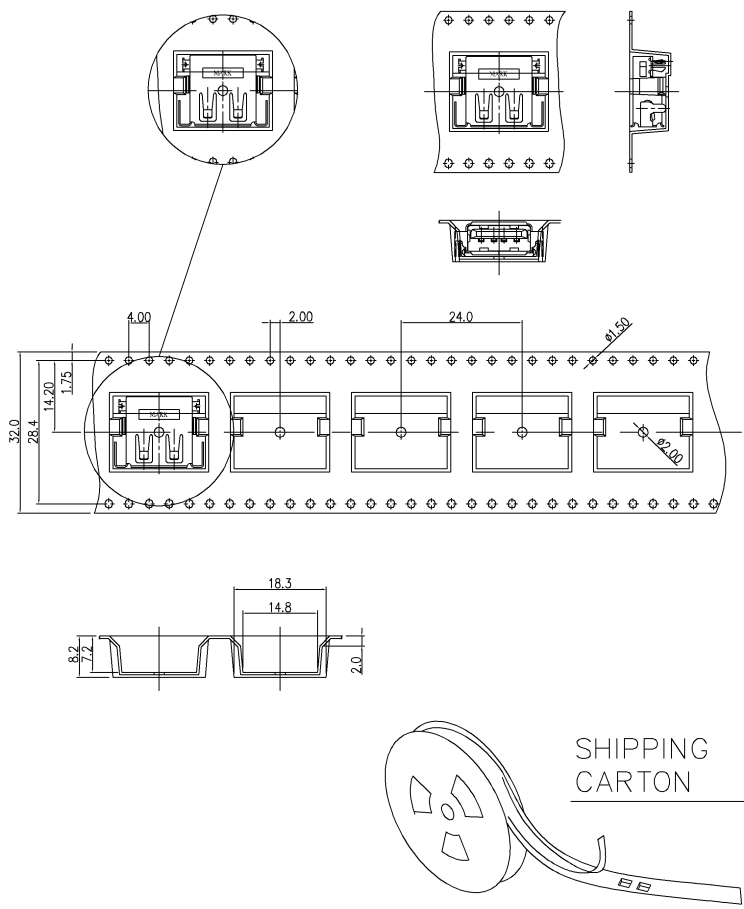

- NOTES:
- MATERIAL:
REEL: PS.
EMBOSSD CARRIER: PS.
COVER TAPE: PBT.
 - DIMENSION :
TAPE REEL: $\phi 330\text{mm} \times 37.1\text{mm}$
SHIPPING CARTON: L=350mm, W=350mm, H=350mm
 - QUANTITY :
PRIMARY PACKING: 300PCS/REEL
SECONDARY PACKING: 9REELS/CARTON(2,700PCS).
 - WEIGHT :
NET WEIGHT: 0.44KG/REEL, 4.00 KG/CARTON.
GROSS WEIGHT: 1.81 KG/REEL, 9.05 KG/CARTON.
 - PEELING RESISTANCE: 20G TO 130G.
 - PEELING SPEED: 300MM/MIN.

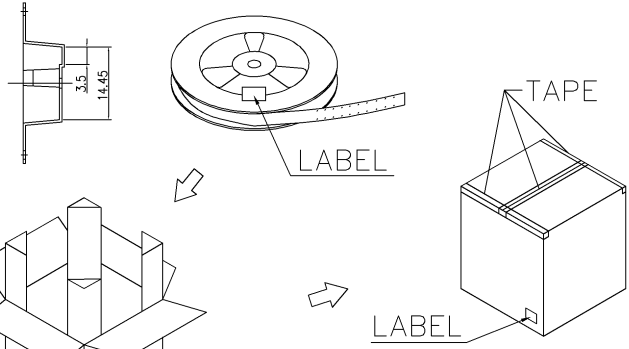

SEE SHEET 1.	ECN	DWN/CHK	DATE
LTR	REVISION RECORD		

2700		300		6-1734081-2	
USB/ CARTON		PCS/ TAPE & REEL		PART NUMBER	
DWN		O. HU		TYCO	
0 PLC ±		24-JAN-2006		TYCO HOLDINGS (BERMUDA)	
1 PLC ±				VII LTD. TAIWAN BRANCH	
2 PLC ±		S. HOU		NAME	
3 PLC ±		24-JAN-2006			
ANGLES ±					
MATERIAL		APVD		W.J. KE	
SEE NOTE		PRODUCT SPEC		24-JAN-2006	
FINISH		APPLICATION SPEC		LOC	
SEE NOTE		WEIGHT		SCALE	
				SIZE	
				DRAWING NO	
				C-1734081	
				REV	
				B	
				SHEET	
				14 OF 14	

CUSTOMER DRAWING