

Tous droits strictement reserves. Reproduction ou communication a des tiers interdite sous quelque forme que ce soit sans autorisation écrite du propriétaire. Propriete de C.FCI. Droits de reproduction FCI.

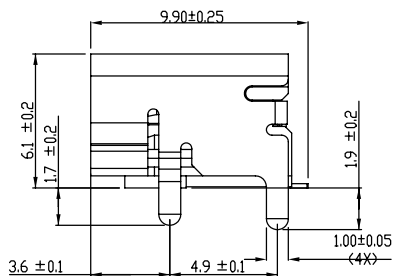

All rights strictly reserved. Reproduction or issue to third parties in any form whatever is not permitted without written authority from the proprietor. Property of FCI. Copyright FCI.

PRODUCT NO.  
10029449-X01XLF

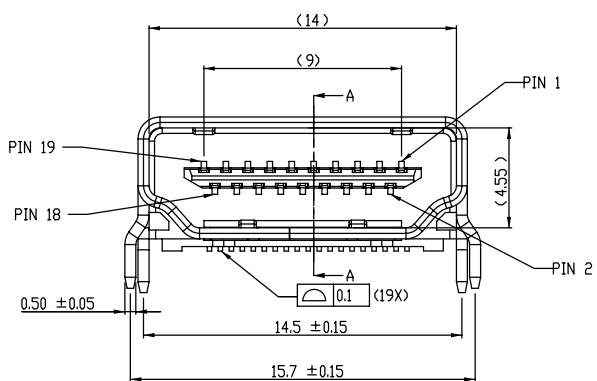
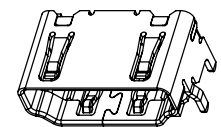
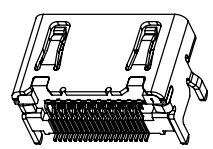
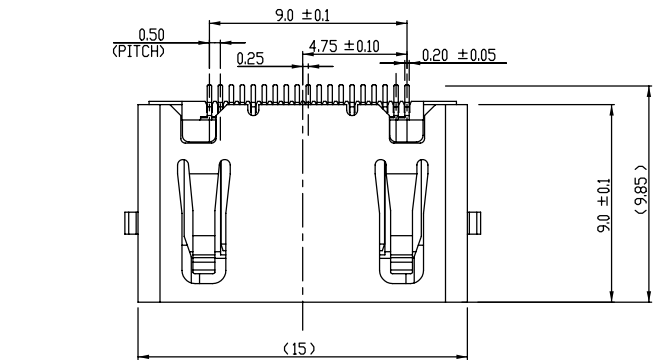

SECTION A-A

Mark with  
10029449-001  
REV. 1  
in area indicated  
by X.....

GENERAL DIMENSION	TOLERANCE	ANGLE
±0.8	X*±	
.x±0.4	X*±2°	
.xx±0.2		

rev	ecm no	dr	date
L	N09-0159	SH	05/27/09
M	N09-0307	SH	10/21/09
N	N10-0033	SH	02/01/10

		www.fciconnect.com		tolerance	projection	size	Scale
Dr	LEIF SHEN	10/15/04	Product family			A4	1.000
Eng	LEIF SHEN	10/15/04	Spec ref	*			
Chr	PAUL WANG	10/15/04	Material	SEE NOTES	ECN		
Appr	JOSEPH HSIA	10/15/04					
title			HDMI TYPE A RECEPTACLE		eng no	10029449	
catalog no			*		CUSTOMER	sheet 1 of 4	
					Rev.	N	

Tous droits strictement réservés. Reproduction ou communication à des tiers interdite sous quelque forme que ce soit sans autorisation écrite du propriétaire. Propriété de C.FCI. Droits de reproduction FCI.



All rights strictly reserved. Reproduction or issue to third parties in any form whatever is not permitted without written authority from the proprietor. Property of FCI. Copyright FCI.

PRODUCT NO.  
10029449-002XLF

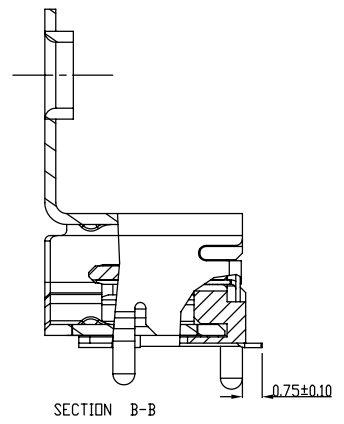
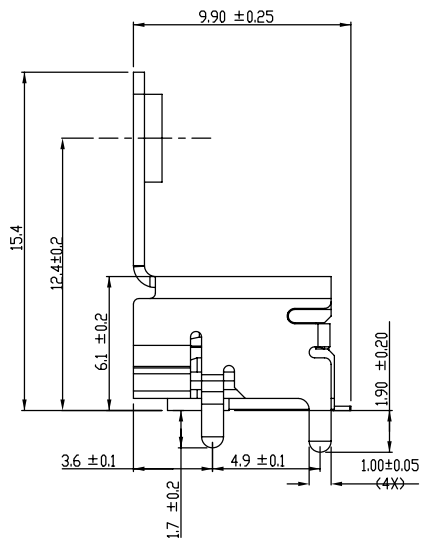
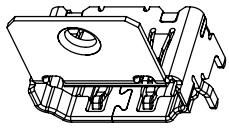
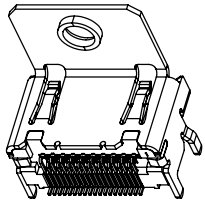
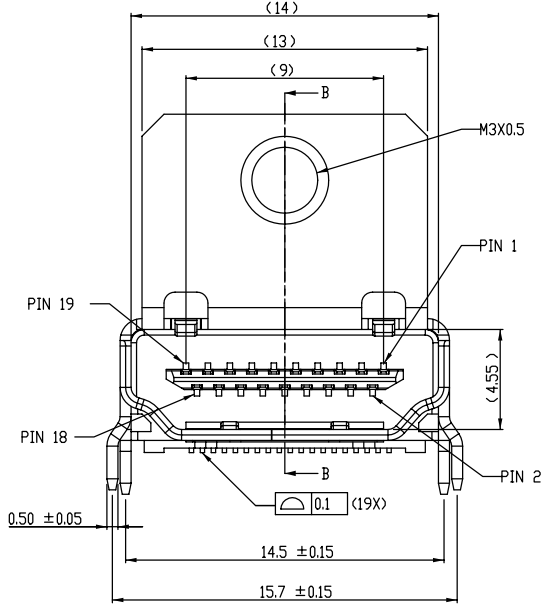
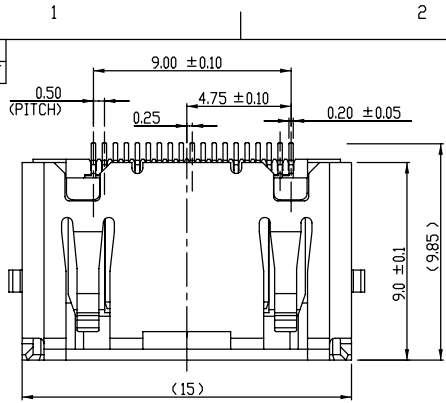

title	HDMI TYPE A RECEPTACLE	dwg no	10029449	Rev.	M
catalog no	HDMI	* CUSTOMER	sheet 2 of 4		

Tous droits strictement réservés. Reproduction ou communication à des tiers interdite sous quelque forme que ce soit sans autorisation écrite du propriétaire. Propriété de FCI. Droits de reproduction FCI.



All rights strictly reserved. Reproduction or issue to third parties in any form whatever is not permitted without written authority from the proprietor. Property of FCI. Copyright FCI.

PRODUCT NO.	CONTACT AREA PLATING	SHIELD FIGURE	PACKING
10029449-001TLF	30u" Au MINIMUM	WITHOUT FLANGE	TRAY
10029449-001RLF	30u" Au MINIMUM	WITHOUT FLANGE	TAPE AND REEL
10029449-101TLF	GOLD FLASH 3u" MIN	WITHOUT FLANGE	TRAY
10029449-101RLF	GOLD FLASH 3u" MIN	WITHOUT FLANGE	TAPE AND REEL
10029449-002TLF	30u" Au MINIMUM	WITH FLANGE	TRAY
10029449-002RLF	30u" Au MINIMUM	WITH FLANGE	TAPE AND REEL
10029449-002FLF	GOLD FLASH 3u" MIN	WITH FLANGE	TAPE AND REEL

NOTES:

1.MATERIAL

- 1-1 HOUSING: GLASS FIBER HIGH-TEMP. RESIN.(UL94V-0)
- 1-2 CONTACT: BRASS
- 1-3 SHELL : STEEL

2 FINISH

- 2-1 CONTACT : Ni UNDER PLATED ALL OVER 50u" MIN  
CONTACT AREA SEE TABLE
- 2-2 SHELL : Ni 100u" MIN.

3 PACKAGING:

PACKAGING SPECIFICATION GS-14-939.

4.RoHS STANDARD SPECIFICATION ACCORDING TO FCI GS-22-008.

5. PARTS MEET REFLOW APPLICATION PEAK TEM. 260 DEGREE C, 10 SECONDS MAX.

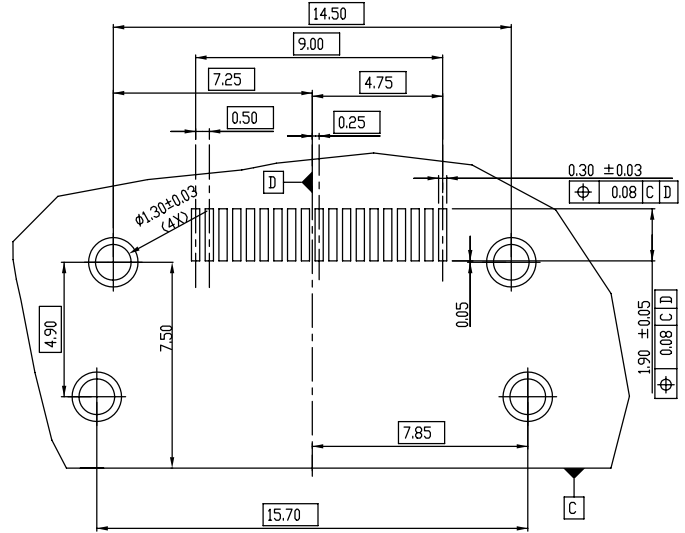

RECOMMENDED PCB PATTERN LAYOUT  
(t=1.6mm)

title	HDMI TYPE A RECEPTACLE	dwg no	10029449	Rev.	N
catalog no	HDMI	*	CUSTOMER	sheet 3 of 4	

3 PDM: Rev:N

STATUS:Released 4 Printed: Aug 01, 2010

Tous droits strictement réservés. Reproduction  
 Communication o des tiers interdite sous quelque  
 forme que ce soit sans autorisation écrite du  
 propriétaire.  
 Propriete de c FCI. Droits de reproduction FCI.



All rights strictly reserved.  
 Reproduction to third parties in any form  
 or by any means is not permitted without  
 written authority from the proprietor.  
 Property of FCI. Copyright FCI.

PRODUCT NO.	CONTACT AREA PLATING	SHIELD FIGURE	PACKING
10029449-111RLF	GOLD FLASH 3u" MIN	WITHOUT FLANGE	TAPE AND REEL

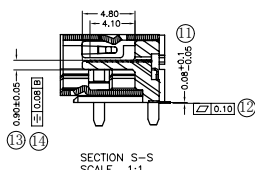
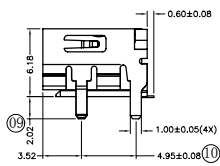
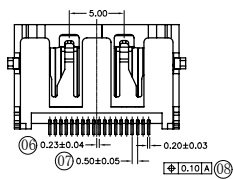
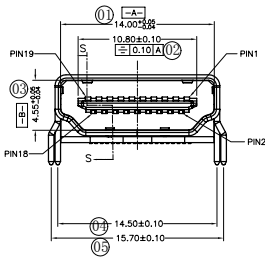
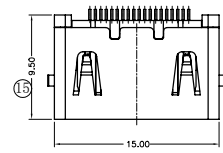

NOTE:  
 1.MATERIAL:  
 HOUSING: HIGH TEMP.THERMOPLASTIC, UL 94V-0  
 COLOR: BLACK.  
 CONTACT: PHOSPHOR BRONZE  
 SHIELD: BRASS  
 2.FINISH:  
 SEE NOTES.  
 3.TERMINAL RETENTION FORCE TO BE 0.3kgf MIN.  
 4.TERMINAL CUT-OFF BURR TO BE 0.05MAX.  
 5.MARKED Ø DIMENSION SHOULD BE MEASURED  
 BY QIP: \* =1,2,3...

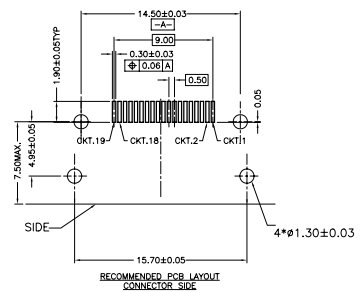

Mark with  
 10029449-001  
 REV. 1  
 in area  
 indicated

Dr		LEIF SHEN	10/15/04	Product family	tolerance	projection	size	Scale
Eng		LEIF SHEN	10/15/04	Spec ref	✓	⊕	A4	1.000
Chr		PAUL WANG	10/15/04	Material	SEE NOTES	ECN		
Appr		JOSEPH HSIA	10/15/04					
Title				HDMI TYPE A RECEPTACLE		DWG no		Rev.
catalog no				HDMI		10029449		N
						CUSTOMER		sheet 4 of 4

GENERAL DIMENSION	TOLERANCE	ANGLE
.±0.8	X*±	
.x±0.4	X*±2°	
.xx±0.2		

Rev	Rev no	dr	date
L	N09-0159	SH	05/27/09
M	N09-0307	SH	10/21/09
N	N10-0033	SH	02/01/10

1

2

3 PDM: Rev:N

STATUS:Released 4 Printed: Aug 01, 2010