

Tous droits strictement réservés. Reproduction ou communication à des tiers interdite sous quelque forme que ce soit sans autorisation écrite du propriétaire. Propriété de © FCI. Droits de reproduction FCI.

All rights strictly reserved. Reproduction or issue to third parties in any form whatever is not permitted without written authority from the proprietor. Property of FCI. Copyright FCI.

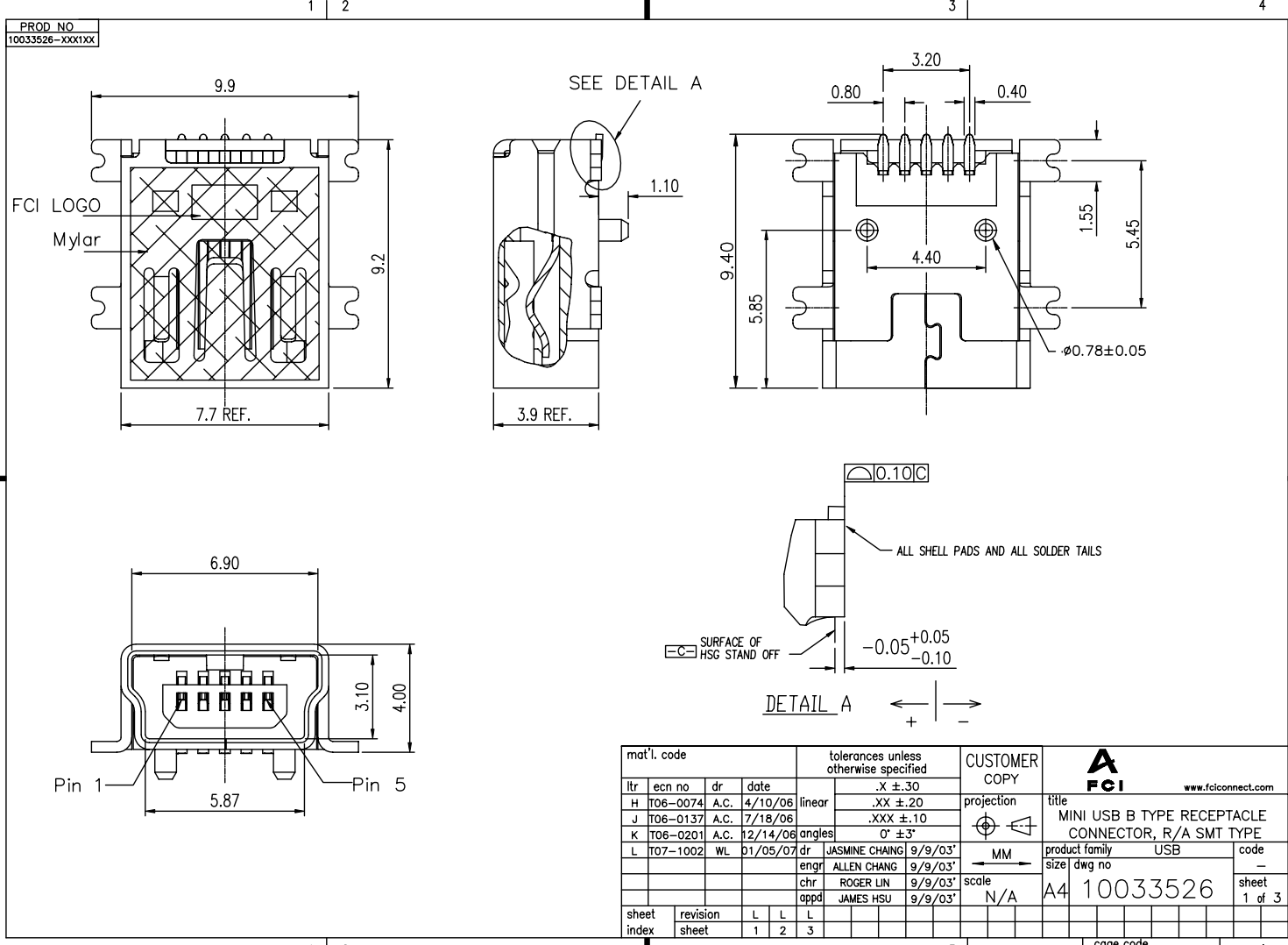

mat'l. code				tolerances unless otherwise specified		CUSTOMER COPY		A FCI www.fciconnect.com	
ltr	ecn no	dr	date	linear	.X ±.30	projection	title	MINI USB B TYPE RECEPTACLE CONNECTOR, R/A SMT TYPE	
H	T06-0074	A.C.	4/10/06		.XX ±.20		product family	code	-
J	T06-0137	A.C.	7/18/06		.XXX ±.10				
K	T06-0201	A.C.	12/14/06	angles	0° ±3°	scale	size	dwg no	sheet
L	T07-1002	WL	D1/05/07	dr	JASMINE CHANG 9/9/03'	N/A	A4	10033526	1 of 3
				enrg	ALLEN CHANG 9/9/03'				
				chr	ROGER LIN 9/9/03'				
				appd	JAMES HSU 9/9/03'				
sheet index	revision sheet	L	L	L					
		1	2	3					

ACAD PDM: Rev:L STATUS Released cage code 22526 Printed: Oct 08, 2008

Tous droits strictement réservés. Reproduction ou communication a des tiers interdite sous quelque forme que ce soit sans autorisation écrite du propriétaire. Property of FCI. Droits de reproduction FCI.

All rights strictly reserved. Reproduction or issue to third parties in any form whatever is not permitted without written authority from the proprietor. Property of FCI. Copyright FCI.

PROD NO
SEE NOTES

1 | 2

3

4

NOTES:

1. MATERIAL:
HOUSING: THERMOPLASTIC. UL 94V-0 RATED, COLOR: BLACK.
CONTACT: COPPER ALLOY.
SHELL: COPPER ALLOY
MYLAR: KAPTON TAPE.
2. FINISH:
CONTACT: UNDERPLATED 50u" MIN. NICKEL OVERALL
100u" MIN. MATTE TIN PLATED ON SOLDERING AREA,
SELECTIVE GOLD PLATED ON CONTACT AREA.
SHIELD: CODE N: PLATED NICKEL WITH 40u" MIN. THICK,
OVER 100u" THICKNESS Cu.
3. 10033526-N3212XLF MEETS THE EUROPEAN UNION DIRECTIVE AS DESCRIBE
IN GS-22-008 AND ITS HSG WILL WITHSTAND EXPOSE TO 260 DEGREE C
PEAK TEMPTURE FOR 10 SECONDS IN A IR REFLOW APPLICATION.
4. PRODUCT SPEC: GS-12-174 ; PACKAGE SPEC: GS-14-873.

5. PRODUCT ORDERING DATA :

FOR LEAD-FREE

10033526 - N X X X X M LF LF: Lead Free

- M: WITH MYLAR
BLANK: WITHOUT MYLAR
- PACKAGING METHOD:
2: TAPE & REEL PACKAGING
- POST OPTION:
1: WITH PLASTIC POST.
2: WITHOUT PLASTIC POST.
- HSG MATERIAL:
2: HIGH TEMP THERMOPLASTIC
- PLATING IN CONTACT AREA:
3: 30u" Au.
N: NICKEL.

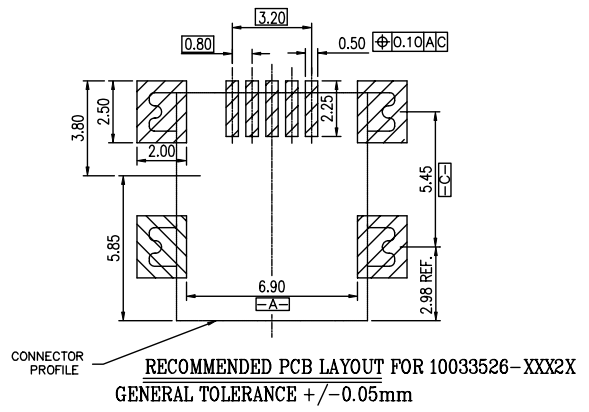
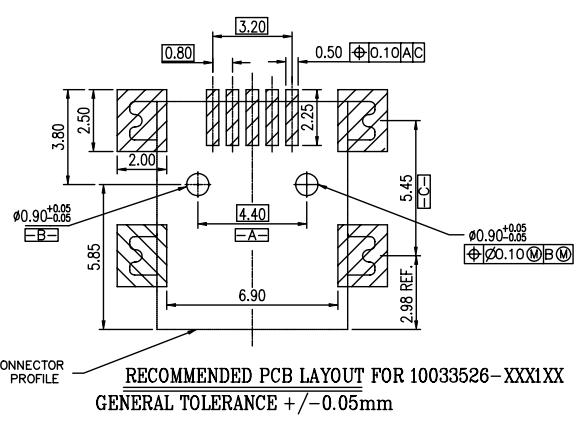

mat'l. code				tolerances unless otherwise specified		CUSTOMER COPY		 www.fciconnect.com	
ltr	ecn no	dr	date	linear	.X ±.30	projection	title		
L					.XX ±.20	 MM	MINI USB B TYPE RECEPTACLE		
				angles	.XXX ±.10		CONNECTOR, R/A SMT TYPE		
					0° ±3°		product family	code	
				dr	JASMINE CHANG 9/9/03'		USB		
				enr	ALLEN CHANG 9/9/03'	scale	size	dwg no	
				chr	ROGER LIN 9/9/03'	N/A	A4	10033526	sheet
				appd	JAMES HSU 9/9/03'				2 of
sheet index	revision sheet								

1 | 2

3

4

ACAD PDM: Rev:L STATUS Released cage code 28526 Oct 08, 2008

Tous droits strictement reserves. Reproduction ou communication a des tiers interdite sous quelque forme que ce soit sans autorisation écrite du propriétaire. Property of FCI. Droits de reproduction FCI.

All rights strictly reserved. Reproduction or issue to third parties in any form whatever is not permitted without written authority from the proprietor. Property of FCI. Copyright FCI.

PROD NO
10033526-xxx2xx

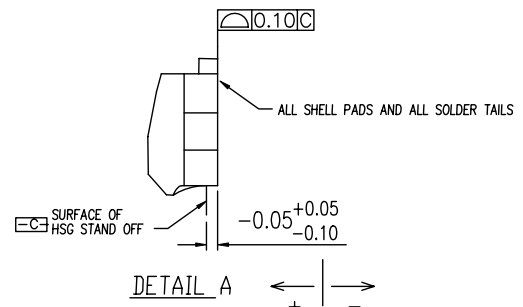
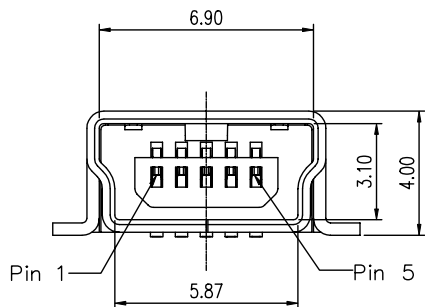
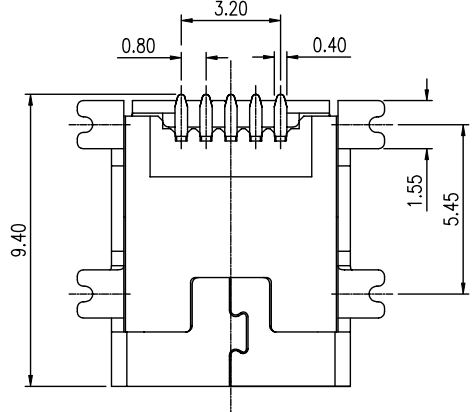
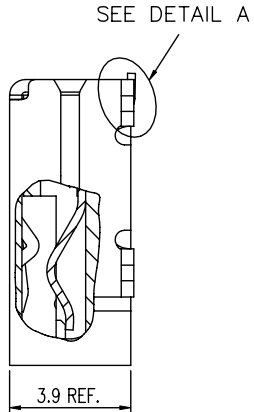
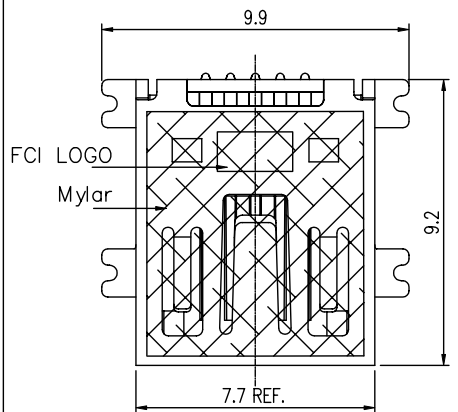

mat'l. code		tolerances unless otherwise specified		CUSTOMER COPY		 www.fciconnect.com	
ltr	ecn no	dr	date	linear	projection	title	
L				.X ±.30	 MM	MINI USB B TYPE RECEPTACLE CONNECTOR, R/A SMT TYPE	
				.XX ±.20		product family	code
				.XXX ±.10	size	USB	-
				angles	scale	dwg no	sheet
				0° ±3°	N/A	A4	3 of
				dr	JASMINE CHANG	9/9/03'	
				engr	ALLEN CHANG	9/9/03'	
				chr	ROGER LIN	9/9/03'	
				appd	JAMES HSU	9/9/03'	
sheet index	revision sheet						

PDM: Rev:L 3 STATUS Released 22026 Oct 08, 2008