

MINI-POWER CONNECTOR IPD1 SERIES (CC79-X)

Rev. Date: 7/7/2005

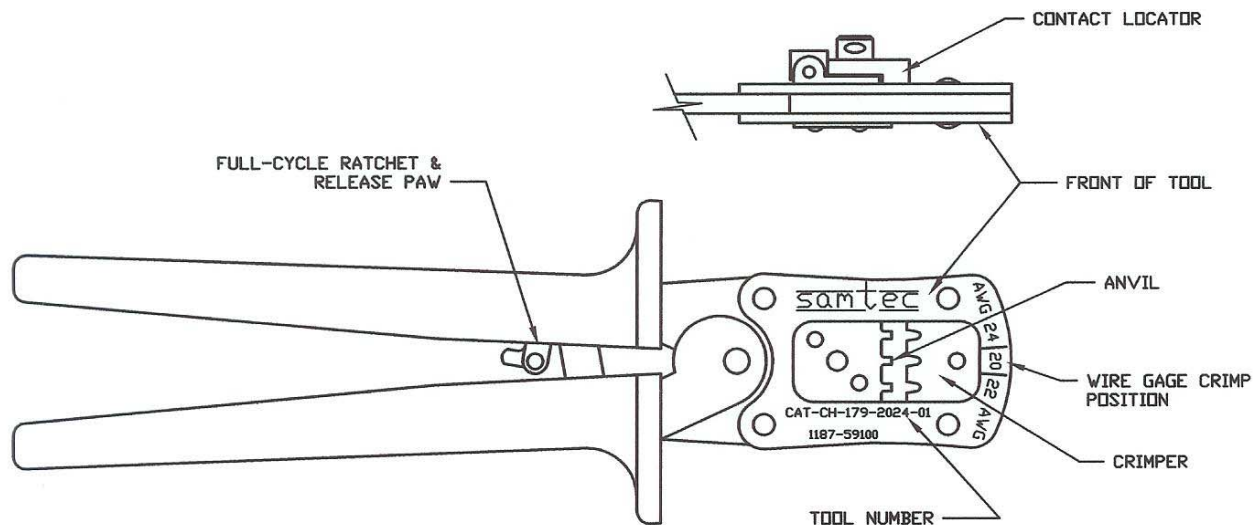

FIGURE 1

PRODUCTS

Terminal No.	Wire Size		Insulation Dia.		Strip Length	
	Awg	MM2	in.	mm	in.	mm
CC79L-2024-01	20-24	0.50-0.20	.035-.070	.89-1.78	.145-.115	3.68-2.92
CC79L-2630-01	26-30	0.12-0.05	.022-.051	.56-1.30		

CRIMP CONDITIONS

Hand Tool No.	Wire Size		Crimp Height		Crimp Tensile	Crimp Width		Crimp Position			
	Awg	mm2	in.	mm		Wire	Cond.	Lft	Ctr	Rt	
CAT-CH-179-2024-01	20	0.50	0.036	0.92	17.1#	1.40 (0.055)	1.78 (0.070)		X		
CAT-CH-179-2024-01	22	0.35	0.034	0.86	11.1#						X
CAT-CH-179-2024-01	24	0.20	0.031	0.79	8.1#			X			
CAT-CH-179-2630-01	26	0.12	0.027	0.67	5.0#	1.07 (0.042)	1.40 (0.055)		X		
CAT-CH-179-2630-01	28	0.08	0.026	0.66	3.2#						X
CAT-CH-179-2630-01	30	0.05	0.025	0.64	2.1#			X			

TOOL DESCRIPTION

The front of the tool (wire insertion side), is marked with the tool number and wire gage range above each termination position (see Figure 1). The tool consists of three fixed dies, (crimpers), three moving dies (anvils), pivoting contact nest, wire locator and full cycle ratchet.

The full-cycle ratchet assures the complete crimping of the contact. Once engaged, the ratchet will not release until the handles are fully closed. The crimping dies bottom before the ratchet

**MINI-POWER CONNECTOR
IPD1 SERIES (CC79-X)**

Rev. Date: 7/7/2005

releases. This feature provides the proper crimp force to assure maximum electrical and mechanical performance. No adjustments are required.

The pivoting contact nest provides the contact with easy loading and precise positioning in the crimping dies.

The wire locator provides two functions. First, it provides a surface to locate the end of the insulation and second, it knocks the completed crimp out of the dies.

CUSTOMER SERVICE

Tooling and product application assistance is available by contacting the **Samtec Application Service Line-(1-800-SAMTEC9)** 8:00 AM to 5:00 eastern time. To expedite your inquiry, have the pertinent part numbers for the product and tooling.

OPERATING PROCEDURE

Note: This tool is should only be used for crimping the terminals listed in this document.

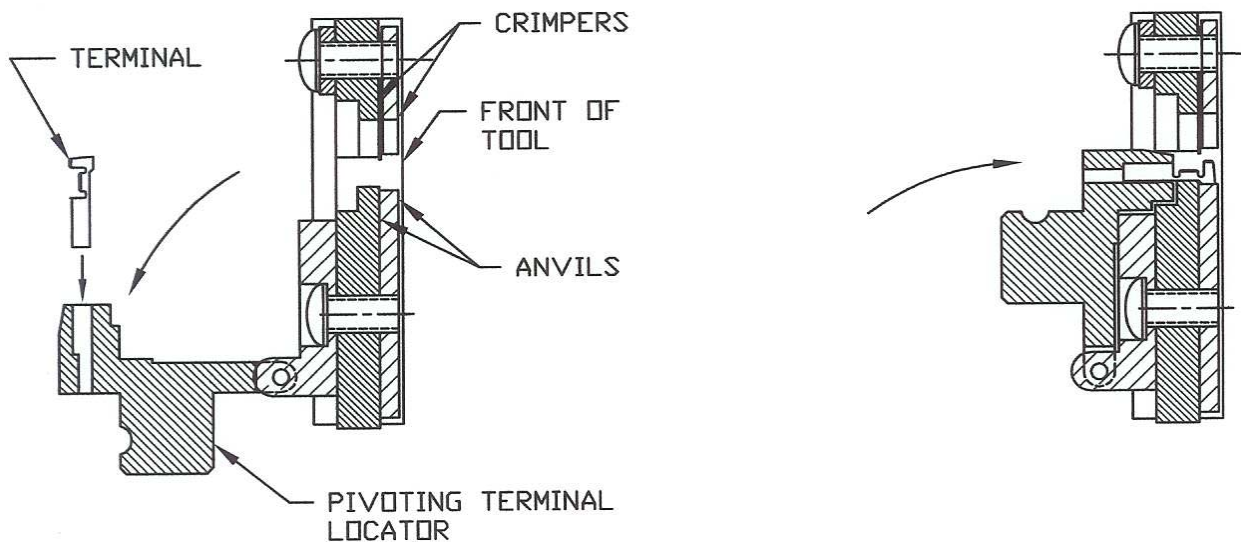
**Step 1**

- Open tool handles to stop.
- Open pivoting terminal locator.
- Insert terminal into locator for desired crimp position. (left, center or right)

Step 2

- Close terminal locator

**MINI-POWER CONNECTOR
IPD1 SERIES (CC79-X)**

Rev. Date: 7/7/2005

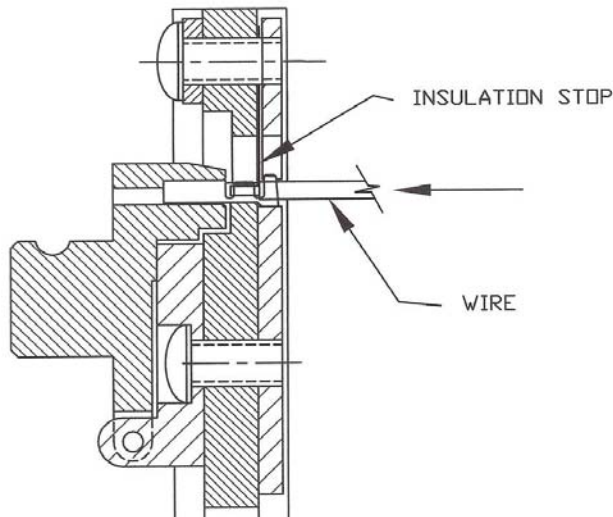
**STEP 3**

- Partially close the tool to hold the terminal in place (up to one ratchet click).
- Insert the wire into terminal until the end of the insulation is against the stop.
- Close handles until the ratchet releases.
- Open handles fully so that the insulation stop can eject the terminal from crimpers.
- Remove the completed termination.

MAINTENANCE

- Keep tool free of dust, moisture and other contaminants using a clean brush or lint free cloth.
- Make sure that the retaining pins are in place and that they are secured with retaining rings.
- All pivot pins and sliding surfaces should be provided with a thin coat of SAE No. 20 oil. Keep oil out of crimp tools.
- When the tool is not in use, keep handles closed to prevent objects from becoming lodged in the crimp tooling. Store the tool in a clean, dry area.

MIS-CRIMPS AND JAMS

If the tool becomes jammed in the partially closed position, do not attempt to force the handles open or closed. The tool can be opened easily by releasing the ratchet paw between the handles.

NOTES:

- Samtec does not repair hand tools. If the tooling becomes damaged or worn, a new tool must be purchased.
- This tool is not adjustable for crimp height and is intended for standard conductor sizes. It may not give a good insulation support crimp for all insulation sizes.
- Pull force should be used as the final criteria for an acceptable crimp. A complete evaluation for crimp quality can be found in Application Specification STS-A-001.
- This hand tool is intended for low volume, prototyping or repair only. **Repetitive use of this tool should be avoided.**