

Tous droits strictement reserves. Reproduction ou communication a des tiers interdite sous quelque forme que ce soit sans la permission écrite de la proprietaire. Property of FCI. - Droits de reproduction FCI.

All rights strictly reserved. Reproduction or issue to third parties in any form whatever is not permitted without written permission of FCI. - Copyright FCI.

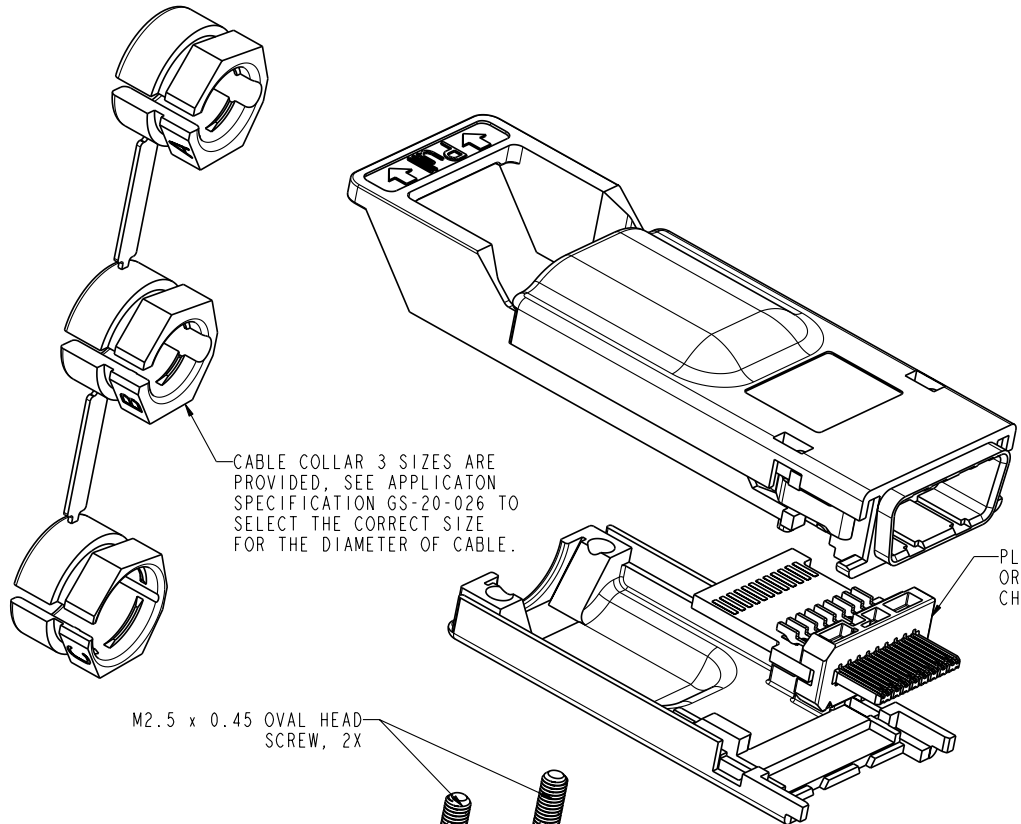

PRODUCT NO.
SEE TABLE



CABLE COLLAR 3 SIZES ARE PROVIDED, SEE APPLICATION SPECIFICATION GS-20-026 TO SELECT THE CORRECT SIZE FOR THE DIAMETER OF CABLE.

PLUG ASSEMBLY WITH OR WITHOUT PCB, SEE CHART ON SHEET '5

M2.5 x 0.45 OVAL HEAD SCREW, 2X

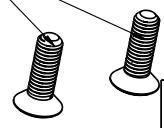

rev	ecn no	dr	date
C	V03-0415	GIP	04/15/03
D	V03-0796	GIP	07/21/03
E	V03-0971	DAI	10/23/03
F	V04-0008	DAI	01/28/04
G	V04-0508	DAI	06/16/04
H	V05-0064	TAB	03/03/05
J	V05-0528	DAI	06/30/05

www.fciconnect.com		surface 3.2 ASME Y14.5	tolerance ASME Y14.5	projection 	MM
Dr	D.FUSSELMAN	2/28/02	Product family	EYEMAX(tm)	Scale 1:1
Eng	S.OLSON	2/21/02	Spec ref	-	
Chr	T.BRUNGARD	7/30/02	Material	SEE NOTES	ECN V05-0528
Appr	D.BRANN	7/30/02			
title 4X PLUG KIT EYEMAX(tm)			size A4	ECN V05-0528	Rev. J
catalog no				58441	sheet 1 of 5

Tous droits strictement réservés. Reproduction ou communication à des tiers interdite sous quelque forme que ce soit sans l'autorisation écrite du propriétaire. Property of FCI. - Droits de reproduction FCI.



All rights strictly reserved. Reproduction or issue to third parties in any form whatever is not permitted without written permission of the owner. Property of FCI. - Copyright FCI.

PRODUCT NO.
SEE TABLE

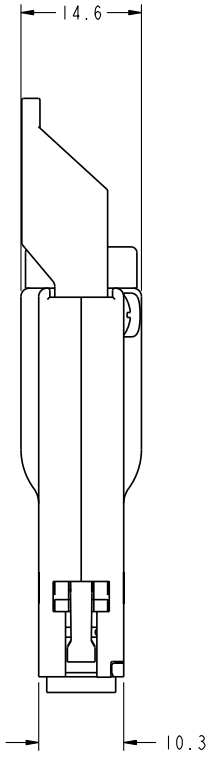
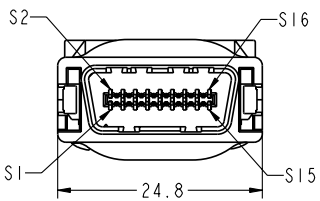
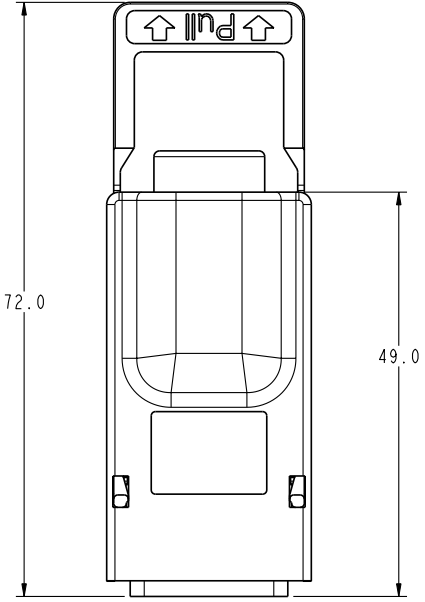
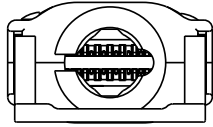

	title	4X PLUG KIT	draw no	58441	Rev.	J
	Pro/E file	catalog no	-	CUSTOMER	sheet 2 of 5	

3 PDM: Rev:J STATUS Released 4 Printed: Jul 22, 2010

Tous droits strictement réservés. Reproduction ou
 Communication à des tiers interdite sous quelque
 forme que ce soit sans l'autorisation écrite de la
 Propriété de FCI. Droits de reproduction FCI.

All rights strictly reserved. Reproduction
 or issue to third parties in any form
 whatever is not permitted without written
 permission of FCI. Copyright FCI.



PRODUCT NO.
 SEE TABLE

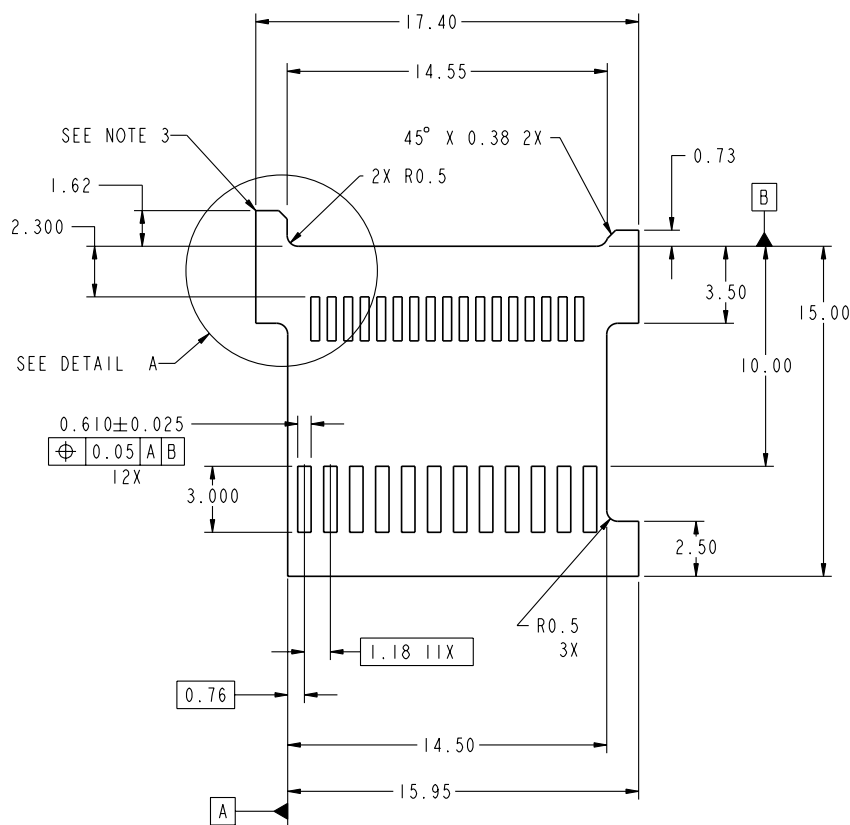

**RECOMMENDED PCB LAYOUT,
 FOR UNEQUALIZED PLUG ASSEMBLY**

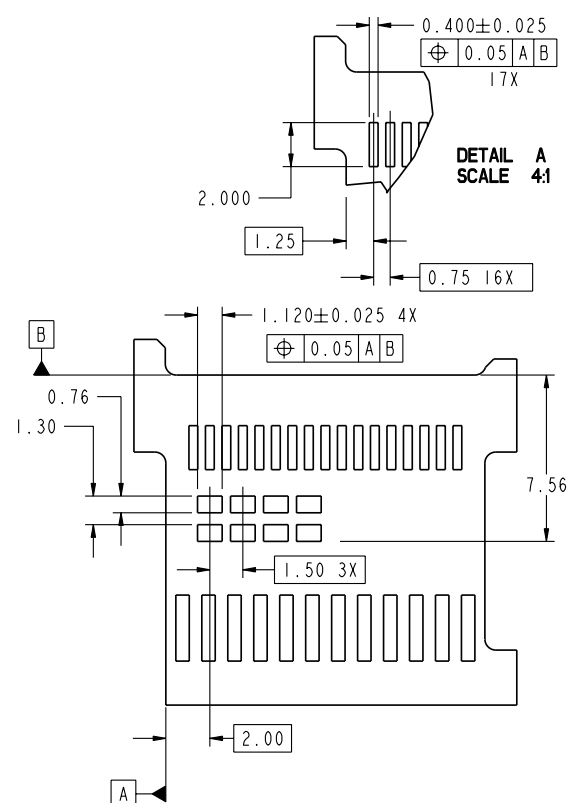

**RECOMMENDED PCB LAYOUT,
 FOR EQUALIZED PLUG***

*COMPONENT PADS ADDED TO EQUALIZED PCB,
 ALL OTHER DIMENSIONS THE SAME AS
 UNEQUALIZED PCB AS SHOWN.

title	4X PLUG KIT	dwg no	58441	Rev.	J
catalog no	EYEMAX (tm)		CUSTOMER	sheet	3 of 5

Tous droits strictement réservés. Reproduction ou communication à des tiers interdite sous quelque forme que ce soit sans l'autorisation écrite de la propriété de FCI. Droits de reproduction FCI.



All rights strictly reserved. Reproduction or issue to third parties in any form whatever is not permitted without written permission of FCI. Property of FCI. Copyright FCI.

PRODUCT NO.
SEE TABLE

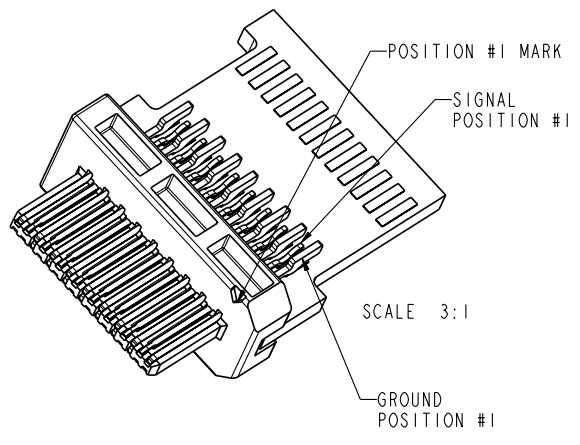
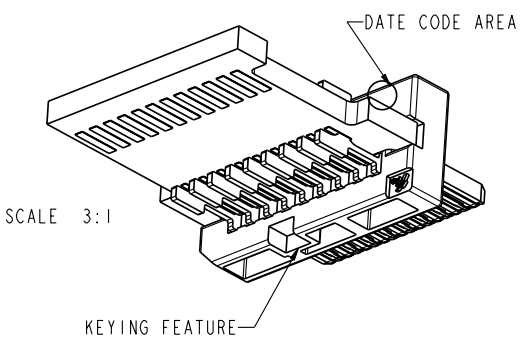

title	4X PLUG KIT	58441	Rev. J
	EYEMAX (1m)		
catalog no		CUSTOMER	sheet 4 of 5

PDM: Rev:J STATUS **Released** 4 Printed: Jul 22, 2010

Tous droits strictement réservés. Reproduction ou communication à des tiers interdite sous quelque forme que ce soit sans l'autorisation écrite du propriétaire. Propriété de FCI. Droits de reproduction FCI.



All rights strictly reserved. Reproduction or issue to third parties in any form whatever is not permitted without written permission of the owner. Property of FCI. Copyright FCI.

PRODUCT NUMBER	DESCRIPTION
58441-001	PLUG KIT WITH UNEQUALIZED P1 PCB
58441-002	PLUG KIT WITHOUT PCB
58441-003	PLUG KIT WITH EQUALIZED P1 PCB WITHOUT COMPONENTS
58441-004	PLUG KIT WITH EQUALIZED P1 PCB WITH COMPONENTS
58441-101	PLUG KIT WITH UNEQUALIZED P2 PCB
58441-103	PLUG KIT WITH EQUALIZED P2 PCB WITHOUT COMPONENTS
58441-104	PLUG KIT WITH EQUALIZED P2 PCB WITH COMPONENTS

* ADD LF TO PART NUMBER FOR LEAD FREE SOLDER TAILS
 EXAMPLE: 58441-001LF, SEE NOTES 1, 4, 7, AND 8

NOTES:

- ① PACKAGING SPECIFICATION GS-14-794
 PACKAGING OF LEAD FREE PRODUCTS MEETS LABELING AND PACKAGING SPECIFICATION GS-14-920.
2. APPLICATION SPECIFICATION GS-20-026 FOR PADDLE CARD TERMINATION DETAILS. FOR EASE OF WIRE MANAGEMENT, A P1 ASSEMBLY IS RECOMMENDED ON ONE END OF THE CABLE AND P2 ASSEMBLY ON THE OTHER END.
3. PRODUCT SPECIFICATION GS-12-209
- ④ MATERIAL:
 CONTACTS: COPPER ALLOY WITH GOLD OVER NICKEL PLATING IN THE CONTACT AREA AND TIN/LEAD PLATING ON SOLDER TAIL UNLESS PART NUMBER ENDS IN LF. LEAD FREE SOLDER TAIL PLATING 2um (80u") MIN MATTE TIN OVER 1.27um (50u") MIN NICKEL UNDERPLATE.
 HOUSING: HIGH TEMPERATURE THERMOPLASTIC, UL 94V-0 RATED, SUITABLE FOR REFLOW SOLDERING
 SHELLS: ZINC WITH NICKEL PLATING AND COPPER UNDERPLATING
 PULL TAB & CABLE COLLAR: THERMOPLASTIC
 LATCH: STAINLESS STEEL
5. MATES WITH RECEPTACLE 58368 OR 58369
6. PLUG ASSEMBLIES, COVER ASSEMBLY KITS (58476) AND CABLE COLLARS (10007239) CAN BE PURCHASED AS SEPARATE ITEMS. PLUG ASSEMBLY DRAWINGS ARE 58443-NO PCB, 58638-UNEQUALIZED, 10026692-EQUALIZED.
- ⑦ IF LEAD FREE PART NUMBER, THE HOUSING WILL WITHSTAND EXPOSURE TO 260°C PEAK TEMPERATURE FOR 10 SECONDS IN A WAVE SOLDER APPLICATION WITH A 1.60mm MIN THICK CIRCUIT BOARD.
- ⑧ LEAD FREE PRODUCTS MEET EUROPEAN UNION DIRECTIVES AND OTHER COUNTRY REGULATIONS AS DESCRIBED IN GS-22-008.

PCB NOTES:

1. PADS ON BOTH SIDES OF PCB.
2. DIMENSIONS APPLY TO BOTH SIDES OF PCB LOCATED FROM DATUMS A & B.
- ③ THIS AREA NOT TO USED TO LOCATE SOLDER TAILS TO SOLDER PADS, THIS AREA IS TO AID IN ASSEMBLY BY LIMITING TOP TO BOTTOM MOVEMENT OF THE PADDLE CARD.
4. PCB THICKNESS: 1.57mm (.062").

title	4X PLUG KIT	drwg no	58441	Rev.	J
catalog no	EYEMAX(1m)		CUSTOMER	sheet	5 of 5

3 PDM: Rev:J

STATUS Released

4 Printed: Jul 22, 2010

A
B
C
D