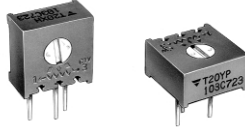
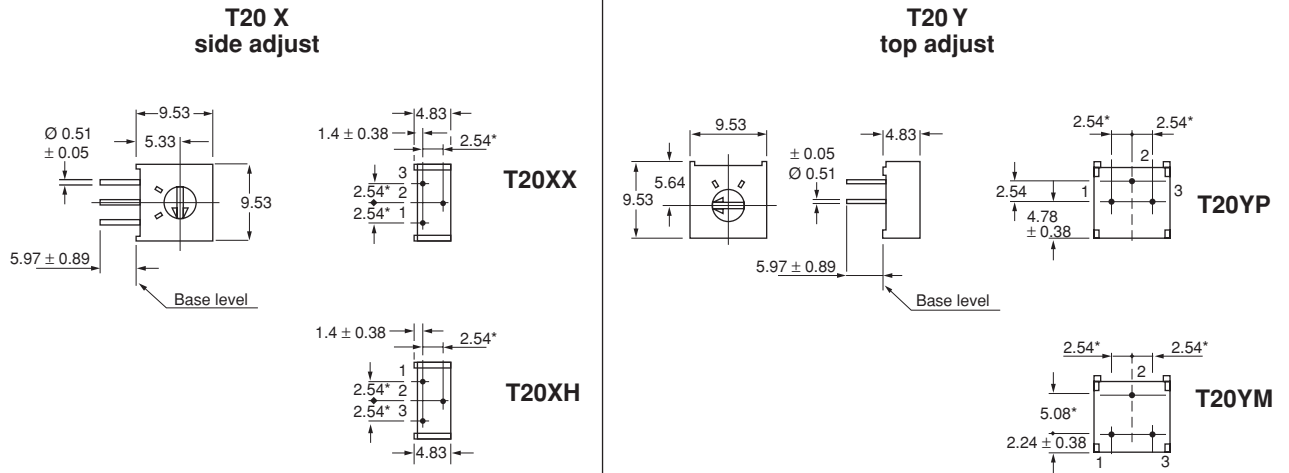

3/8" Square, Single Turn Sealed Cermet Trimmers

FEATURES

- Industrial grade
- 0.5 Watt at 85°C
- CECC 41100
- Full sealed
- 4 standard pin styles
- Easy to read scale

DIMENSIONS in millimeters

Screwdriver slot: long 3.15
wide 0.76 - deep 0.76

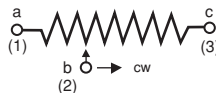
CIRCUIT DIAGRAM

- *To be measured at base level.
- Tolerances unless otherwise specified ± 0.5 mm.



ELECTRICAL SPECIFICATIONS		
Resistive Element		cermet
Electrical Travel		280°
Resistance Range		10Ω to 2MΩ
Standard Series		1 - 2 - 5..
Tolerance Standard		± 10%
Power Rating	Linear	0.5W at 85°C
	Logarithmic	not applicable
Temperature Coefficient		See Standard Resistance Element Data
Limiting Element Voltage (linear law)		300V
Contact Resistance Variation		2% Rn or 3Ω
End Resistance (typical)		1Ω
Dielectric Strength (RMS)		900V
Insulation Resistance (500VDC)		10 ³ MΩ

MECHANICAL SPECIFICATIONS

Mechanical Travel	310°
Operating Torque (max. Ncm)	3.5
End Stop Torque (min. Ncm)	10.5
Unit Weight (max. g)	0.5

ENVIRONMENTAL SPECIFICATIONS

Temperature Range	- 55°C + 125°C
Climatic Category	55/100/56
Sealing	fully sealed container IP67

POWER RATING CHART

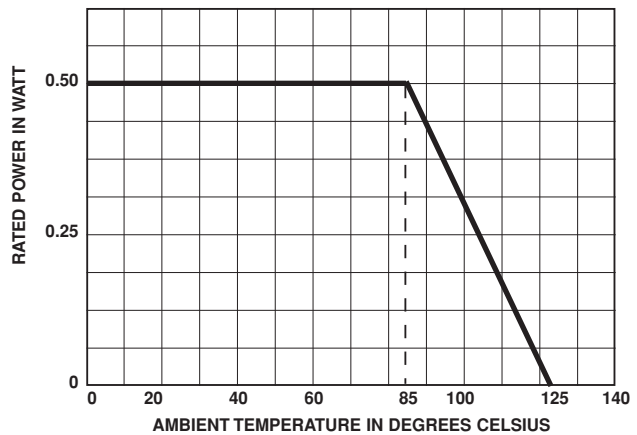

PERFORMANCE			
TESTS	CONDITIONS	TYPICAL VALUES AND DRIFTS	
		$\frac{\Delta R_{ac}}{R_{ac}}$ (%)	$\frac{\Delta R_{ab}}{R_{ab}}$ (%)
Load Life	1000h at rated power 90'/30' - ambient temperature 85°C	± 1% Contact resistance variation : < 1% Rn	± 2%
Climatic Sequence	Phase A dry heat 100°C Phase B damp heat Phase C cold - 55°C Phase D damp heat 5 cycles	± 1%	± 2%
Long Term Damp Heat	56 days	± 1% Dielectric strength : 1000 VRMS Insulation resistance : > 10 ⁴ MΩ	± 2%
Rapid Temperature Change	5 cycles - 55°C at + 125°C	± 1%	$\frac{\Delta V_{ab}}{V_{ac}}$: ± 2%
Shock	50g 11ms 3 successive shocks in 3 directions	± 0.5%	± 1%
Vibration	10 - 55Hz 0.75mm or 10g during 6 hours	± 0.5 %	$\frac{\Delta V_{ab}}{V_{ac}}$: ± 1%
Rotational Life	200 cycles	± 3% Contact resistance variation : < 2% Rn	



STANDARD RESISTANCE ELEMENT DATA				
STANDARD RESISTANCE VALUES	LINEAR LAW			T.C. -55°C +125°C
	MAX. POWER AT 85°C	MAX. WORKING VOLTAGE	MAX. CUR. THROUGH ELEMENT	
Ω	W	V	mA	ppm/°C
10	0.5	2.2	224	+ 200
20		3.2	160	
50		5	100	
100	↓	7	70	±100
200		10	50	
500		15.8	32	
1k		22.4	22	
2k		31.8	16	
5k		50	10	
10k		70.7	7	
20k		100	5	
50k		158	3.2	
100k		0.5	224	
200k	0.45	300	1.5	
500k	0.18	300	0.6	
1M	0.09	300	0.3	
2M	0.05	300	0.15	

MARKING

VISHAY logo, style, ohmic value, manufacturing date, pin '3'.

The ohmic value is indicated by a 3 figure code: the first two are significant figures, the third one is the multiplier.

Example : 100 = 10Ω

101 = 100Ω

102 = 1000Ω

503 = 50000Ω

The manufacturing date is indicated by a 3 figure code.

The first digit is the year, the last two are the week number.

PACKAGING
In magazine pack by 50 pieces (tube), code TU50

ORDERING INFORMATION				
T20 SERIES	XH STYLE XX YP XH YM	500kΩ OHMIC VALUE	± 10% TOLERANCE	TU50 PACKAGING TU50: tube