

# MS3419 and AS85049/26 Crimp Ring Backshell



Crimp Ring  
and Banding  
Backshells

Glenair Connector  
Designator A

MIL-DTL-5015 Series 3400,  
MIL-DTL-26482 Series 2,  
AS81703 Series 3,  
MIL-DTL-83723 Series I & III

## M85049/26-1-12 W

Basic Part No. \_\_\_\_\_  
M85049/26-1 = Adapter Only  
M85049/26-2 = Crimp Ring Only  
M85049/26-3 = Adapter with Crimp Ring

Shell Size \_\_\_\_\_

Finish (Not Applicable for M85049/26-2)  
N = Electroless Nickel  
W = 1,000 Hour Cadmium  
Olive Drab Over  
Electroless Nickel

## MS3419-21 C

**Superseded Part Number**

Basic Part No. \_\_\_\_\_  
Adapter Only  
Dash No. \_\_\_\_\_

Finish  
A = Electroless Nickel  
C = 500 Hour Cadmium Olive Drab  
Over Electroless Nickel

Shell Size	A Thread Class 2B	C Dia Max
3	.562 - 24 UNEF	.67 (17.0)
8	.500 - 20 UNF	.62 (15.7)
10	.625 - 24 UNEF	.73 (18.5)
12	.750 - 20 UNEF	.86 (21.8)
14	.875 - 20 UNEF	.98 (24.9)
16	1.000 - 20 UNEF	1.11 (28.2)
18	1.062 - 18 UNEF	1.22 (31.0)
20	1.188 - 18 UNEF	1.35 (34.3)
22	1.313 - 18 UNEF	1.47 (37.3)
24	1.438 - 18 UNEF	1.59 (40.4)
28	1.750 - 18 UNS	1.97 (50.0)
32	2.000 - 18 UNS	2.22 (56.4)
36	2.250 - 16 UN	2.47 (62.7)
40	2.500 - 16 UN	2.72 (69.1)
44	2.750 - 16 UN	2.97 (75.4)
48	3.000 - 16 UN	3.22 (81.8)
61	1.500 - 18 UNEF	1.65 (41.9)

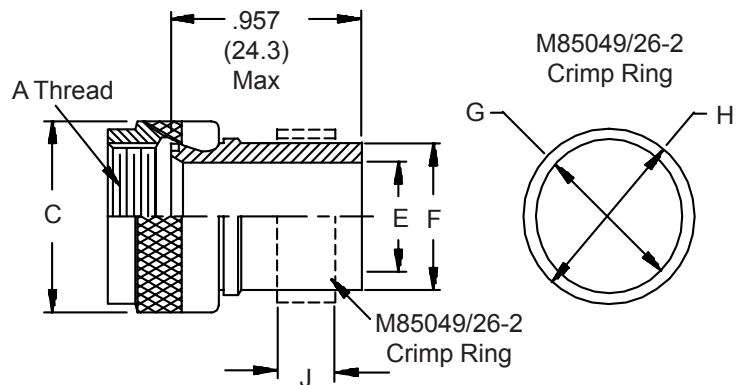

M85049/26-3 (Adapter with Crimp Ring) Shell Size	M85049/26-1 (Adapter Only) MS3419 (Adapter Only)				M85049/26-2 (Crimp Ring Only)				
	Shell Size	E Dia	F Dia		Shell Size	G Min	H Min	J	
3	3	.250 (6.4)	.337 (8.6)						
8	8	.250 (6.4)	.337 (8.6)		8	.400 (10.2)	.448 (11.4)	.250 (6.4)	
10	10	.325 (8.3)	.488 (12.4)		10	.585 (14.9)	.660 (16.8)	.440 (11.2)	
12	12	.420 (10.7)	.500 (12.7)		12	.585 (14.9)	.660 (16.8)	.440 (11.2)	
14	14	.540 (13.7)	.620 (15.7)		14	.705 (17.9)	.780 (19.8)	.440 (11.2)	
16	16	.670 (17.0)	.750 (19.1)		16	.835 (21.2)	.910 (23.1)	.440 (11.2)	
18	18	.789 (20.0)	.880 (22.4)		18	1.005 (25.5)	1.080 (27.4)	.440 (11.2)	
20	20	.914 (23.2)	1.000 (25.4)		20	1.125 (28.6)	1.200 (30.5)	.440 (11.2)	
22	22	1.039 (26.4)	1.120 (28.4)		22	1.245 (31.6)	1.320 (33.5)	.440 (11.2)	
24	24	1.112 (28.2)	1.192 (30.3)		24	1.327 (33.7)	1.402 (35.6)	.440 (11.2)	
28	28	1.389 (35.3)	1.545 (39.2)		28	1.665 (42.3)	1.740 (44.2)	.440 (11.2)	
32	32	1.635 (41.5)	1.795 (45.6)		32	1.915 (48.6)	1.990 (50.5)	.440 (11.2)	
36	36	1.850 (47.0)	2.045 (51.9)		36	2.165 (55.0)	2.240 (56.9)	.440 (11.2)	
40	40	2.065 (52.5)	2.295 (58.3)		40	2.415 (61.3)	2.490 (63.2)	.440 (11.2)	
44	44	2.320 (58.9)	2.545 (64.6)		44	2.665 (67.7)	2.740 (69.6)	.440 (11.2)	
48	48	2.570 (65.3)	2.795 (71.0)		48	2.915 (74.0)	2.990 (75.9)	.440 (11.2)	
61	61	1.210 (30.7)	1.359 (34.5)		61	1.435 (36.4)	1.510 (38.4)	.440 (11.2)	

- For complete dimensions see applicable Military Specification.
- Metric dimensions (mm) are indicated in parentheses.