

# 3M™ Shielded Controlled Impedance (SCI) Latch/Eject Header 2 mm Development Kit Instructions

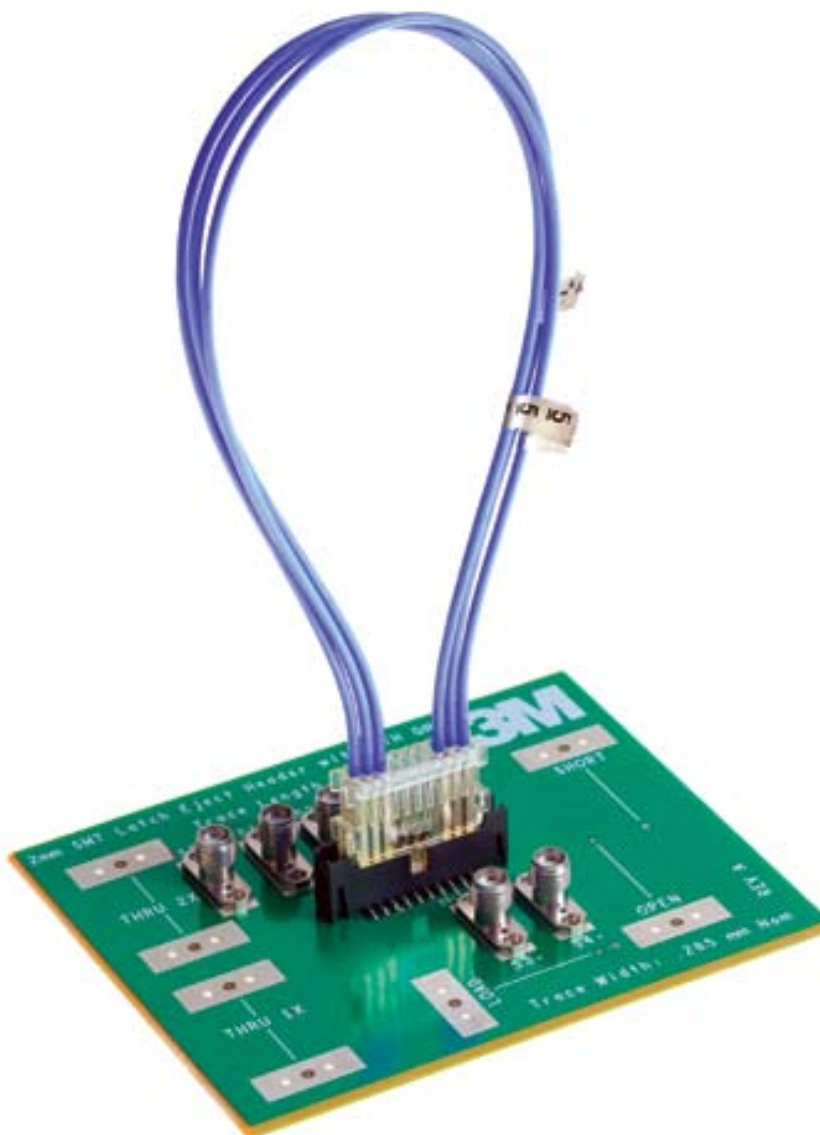

# Contents

1.0 Purpose .....	1
2.0 Development Kits .....	1
A. Kit Part Description	
B. Kit Components	
3.0 Description of Development Kit Components .....	5
A. PCB Test Boards with Header and SMA Connectors	
B. 3M™ SCI Cable Assemblies 2 mm	
C. 3M™ SCI Cable Assembly Carrier 2 mm	
4.0 Testing Guidelines .....	9
5.0 Test Data Examples .....	12
6.0 Additional Technical Assistance and Information .....	13

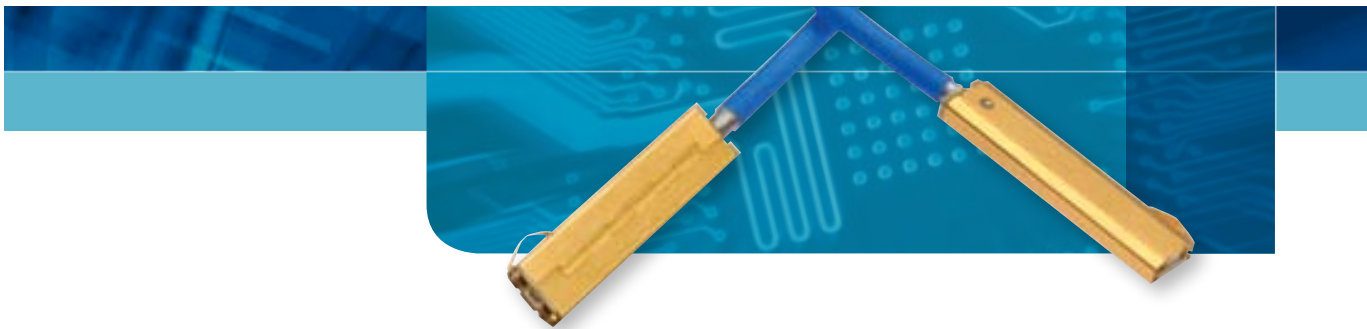

## 1.0 PURPOSE

The purpose of this development kit is to provide the necessary components for testing and characterizing the signal integrity of 3M™ SCI Latch/Eject Headers 2 mm and 3M™ SCI Cable Assemblies, 2 mm, Coaxial and/or Twinaxial. To enable immediate testing, specific kits are provided with headers mounted to a test board populated with multiple single-ended and differential SMA connections. For convenience, these connections allow both ends of a cable assembly to be connected to the same test board for “thru type” measurements. If separate ground planes are desired, two kits may be purchased to perform similar “thru type” measurements utilizing two different test boards.

## 2.0 Development Kits

Kit Part Description	Part #
SCI Latch/Eject SMT Vertical Header 2 mm (without PCB test board)	PN 9401
SCI Latch/Eject SMT Vertical Header 2 mm soldered to PCB	PN 9402
SCI Latch/Eject PTH Vertical Header 2 mm (without PCB test board)	PN 9403
SCI Latch/Eject PTH Vertical Header 2 mm soldered to PCB	PN 9404

For additional development kit ordering information, see Technical Data Sheet TS-2298.

### Kit Components

- A. PCB test board with 3M Latch/Eject Vertical Header 2 mm  
(Part numbers 9402 and 9404 only)

A PCB test board will include a pre-installed vertical header and eight each SMA connectors to enable immediate testing. The SMA connectors are screwed down to the board to provide a compression connection, providing the end user the flexibility to easily replace and/or move to other test locations if needed. If additional channels are needed, the end user can order and install additional SMT type SMA connectors such as Molex part number 73251-1850 or 73251-1851, which includes two lockdown screws.

NOTE: Kits that do not include a PCB test board (i.e. part numbers 9401 and 9403) will include a 2x25 position (SMT or PTH) latch/eject header for assembly to end user's test board.

See 3M™ Latch/Eject Header 2 mm Data Sheet TS-2199 for additional header information.

## **B. 3M™ SCI Cable Assemblies 2 mm**

Each kit provides three each double-ended coaxial and three each twinaxial 2 mm SCI Cable Assemblies. Each assembly is approximately 24 inches long.

See 3M SCI Cable Assembly 2 mm Data Sheet TS-2105 for additional assembly information.

## **C. 3M™ SCI Latch/Eject Cable Assembly Carrier 2 mm**

Each kit provides a 2x25 cable assembly carrier to support and align SCI connectors for insertion into the 2 mm latch/eject header.

See 3M SCI Cable Assembly 2 mm Data Sheet TS-2105 for additional carrier information.



## 3.0 Description of Development Kit Components

### A. PCB Test Boards with Header and SMA Connectors

1. FR4 dielectric material
2. Dielectric constant ( $\approx 4.4$ )
3. Loss tangent ( $\approx 0.035$ )
4. 1oz Cu / 35 micron (1.38 mils)
5. Trace Width: 0.035 mm (0.0125 inches)
6. Trace Length: 25 mm (1 inch)

Each PCB test board is designed with 50 $\Omega$  signal traces routed from SMT SMA's to the latch/eject header...

Four each 50 $\Omega$  single-ended lines (identified S1, S2, S3 and S4)

Four each 100 $\Omega$  Differential lines (S5P/S5N, S6P/S6N, S7P/S7N, S8P/S8N)

Note 1: two 50 $\Omega$  single-ended lines are used to drive 100 $\Omega$  differential lines.

Note 2: "P" = positive signal and "N" = negative sign is for reference only.

Note 3: Header pins (between S2 and S3) and (S6P/S6N and S7P/S7N) are grounded (see crosstalk setup in section 4.0).

Optional calibration traces included (50  $\Omega$  Single-ended)

One each 1x "THRU" trace

One each 2x "THRU" trace

One each "OPEN" trace

One each "SHORT" trace

One each 50  $\Omega$  LOAD trace terminated with 50  $\Omega$  SMT resistor

## PCB test board layout for 3M™ Latch/Eject Header SMT

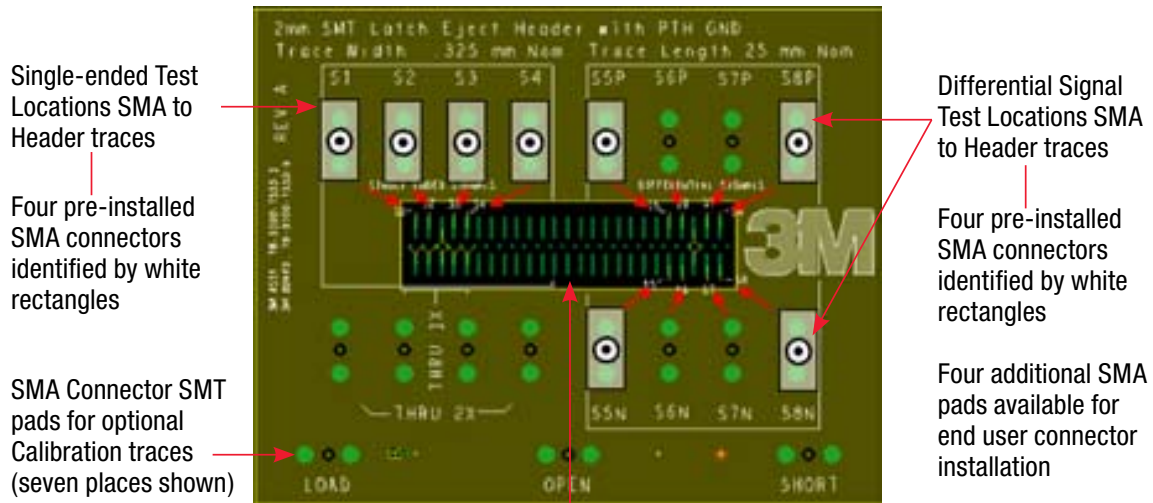

**Latch/Eject Header SMT Pads (2x25 places shown)**  
**Note: Header will be pre-installed**

See 3M Latch/Eject Header Data Sheet  
 TS-2199 for additional information.

## PCB test board layout for 3M™ Latch/Eject Header PTH

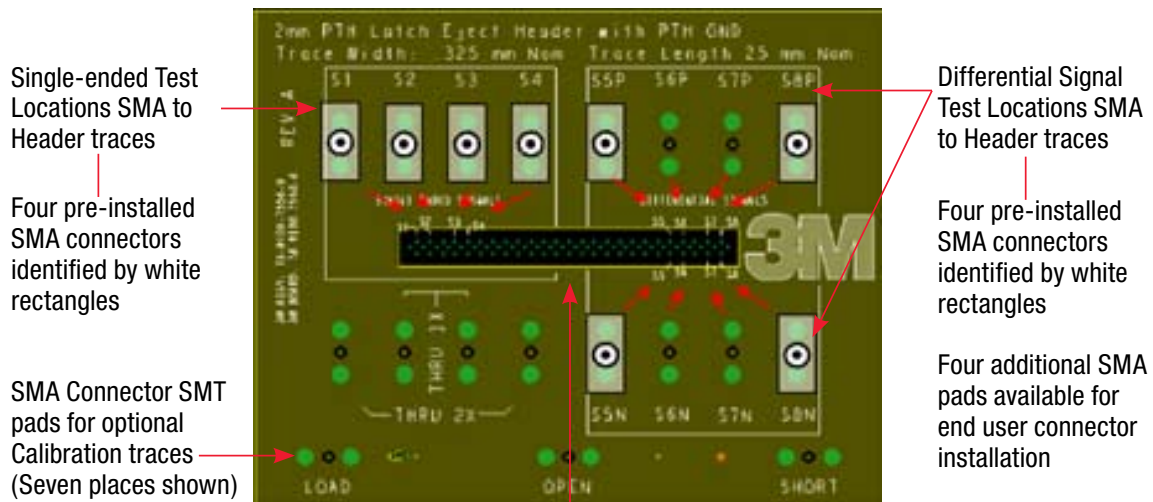

**Latch/Eject Header PTH (2x25 places shown)**  
**Note: Header will be pre-installed**

See 3M Latch/Eject Header Data Sheet  
 TS-2199 for additional information

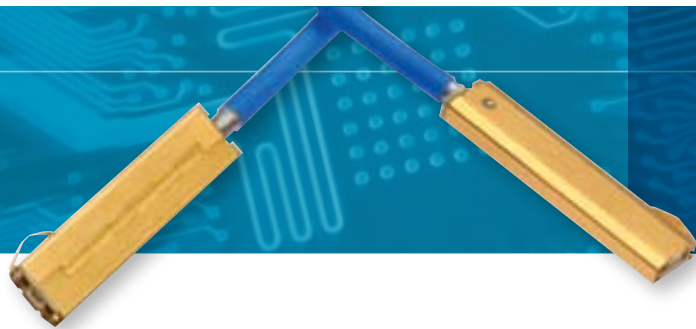

## B. 3M™ SCI Cable Assemblies 2 mm

### SCI Twinaxial Cable Assembly 2 mm

PN 98-3030-058-024.0-0 [3 each]

AWG 26(1) 100  $\Omega$  Low Capacitance Twinaxial Cable with 2 mm SCI Connectors each end.

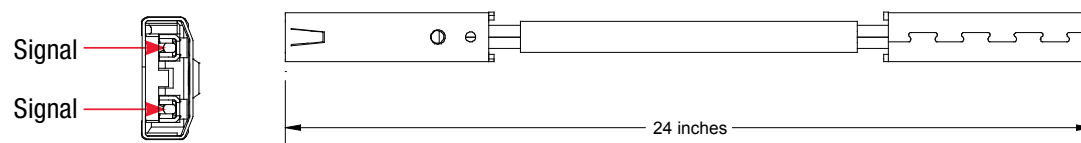

### SCI Coaxial Cable Assembly 2 mm

PN 98-2929-027-024.0-0 [3 each]

AWG 26(7/34) 50  $\Omega$  Low Capacitance Coaxial Cable with 2 mm SCI Connectors each end.

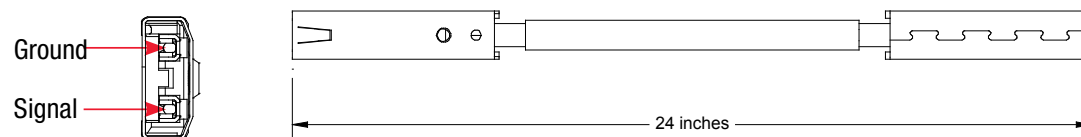

See Cable Assembly Specification TS-2105 for additional information.



## C. 3M™ SCI Cable Assembly Carrier 2 mm

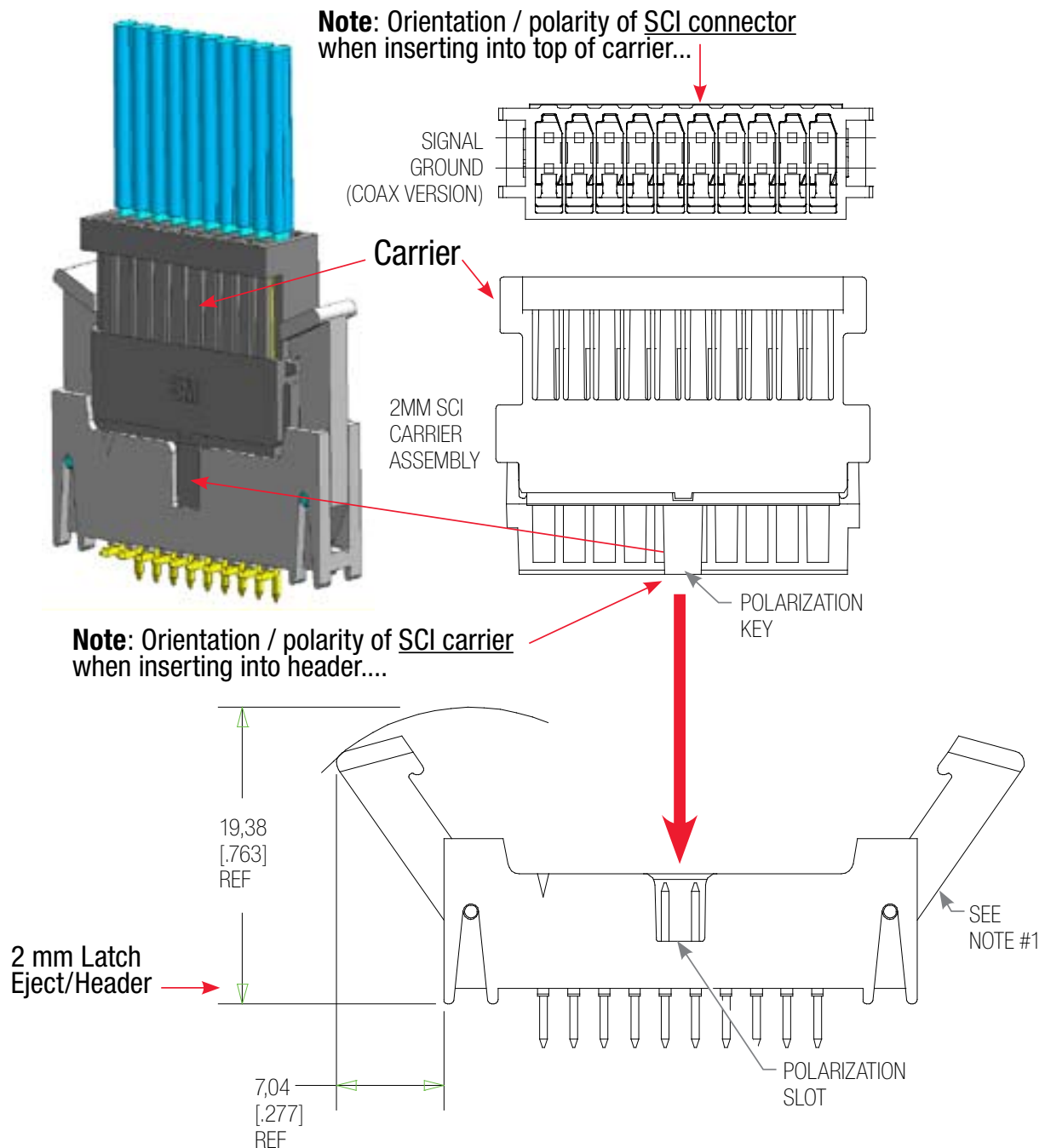

**Note 1:** Latches must be moved to approximate position shown before inserting carrier.

See 3M™ Latch/Eject Header Data Sheet TS-2199 for additional information.



## 4.0 Testing Guidelines

Since this development kit provides the test engineer with multiple signal traces on one PCB, “double-ended” SCI cable assemblies may be connected to the same board to simulate a board-to-board connection scheme. If separate ground planes are desired, two kits (with test boards) may be purchased to perform similar “thru type” measurements.

**Single-ended** or **Differential** Signal Integrity testing that can be performed at locations as noted below...

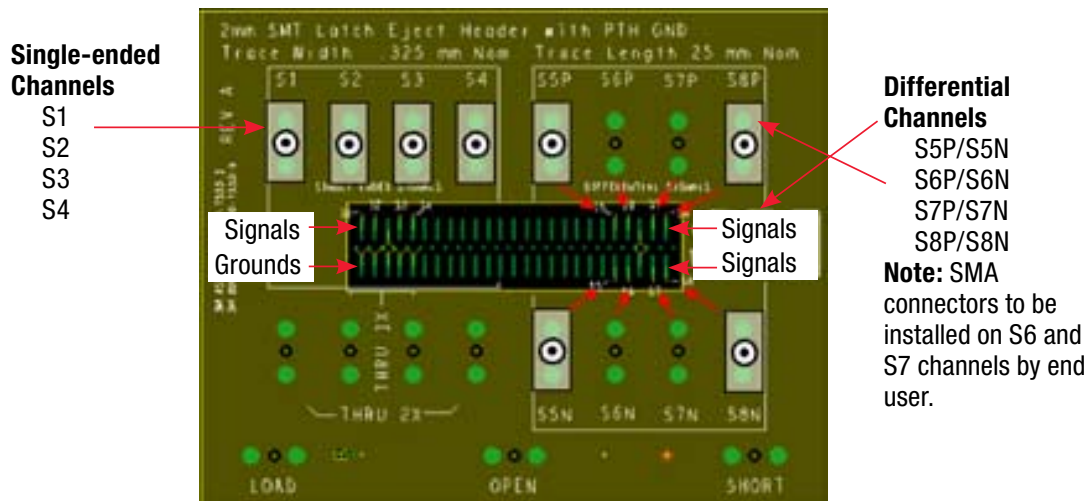

## Testing Options:

### TDR / TDT Testing

**Note 1:** 35ps step input to board typically results in approx 38-40ps rise time at header.

**Note 2:** Impedance of SMA connections typically 50 +/- 5Ω at 40ps rise time.

### Network analyzer “S-Parameter” and Eye Pattern Testing

**Note 1:** SMA and test board losses will be included in measurement unless calibrated out using calibration traces and structures provided.

**Note 2:** End user will need to install SMA connectors for calibration traces in order to eliminate board loss and impedance mis-match of SMA connections.

Examples of TDT, S-Parameter and Eye Pattern “thru” test set-up on the same board...

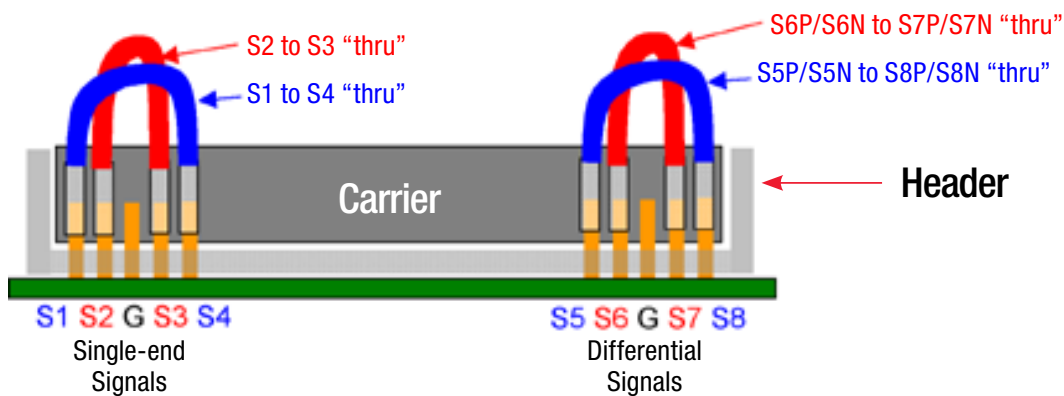

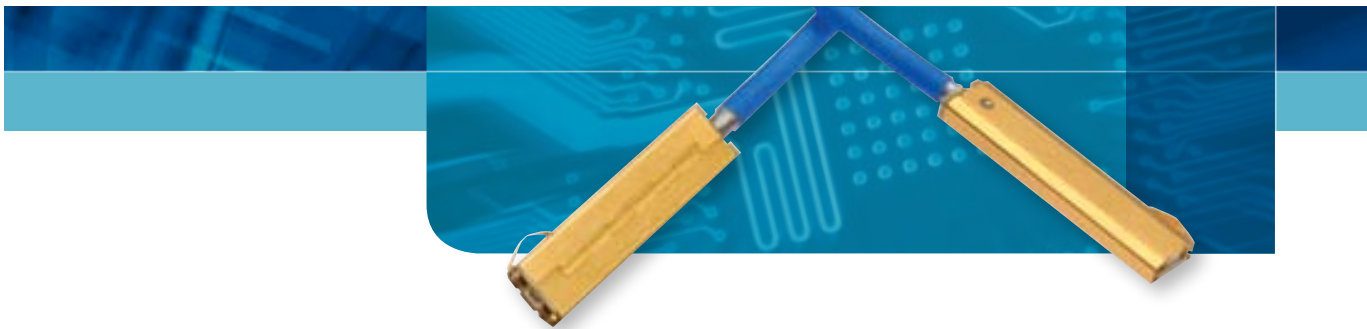

**Crosstalk** Test Setup example for “two adjacent aggressors” on the same board...

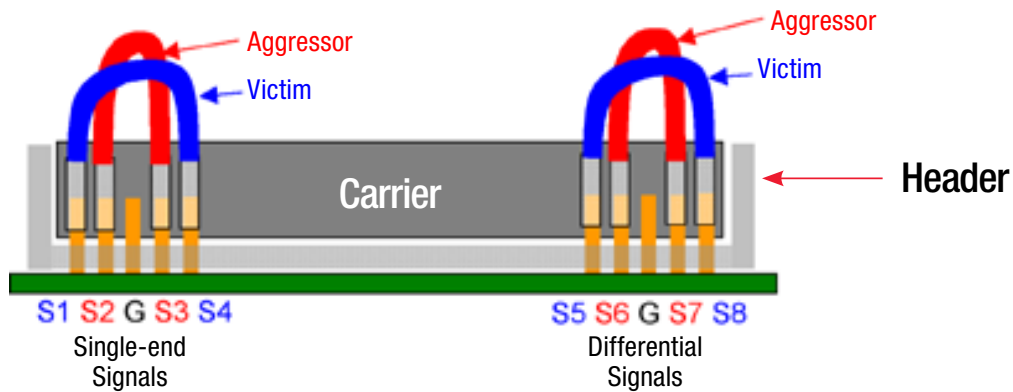

**Crosstalk** Test Setup example for a “single aggressor separated by grounded position” on the same board...

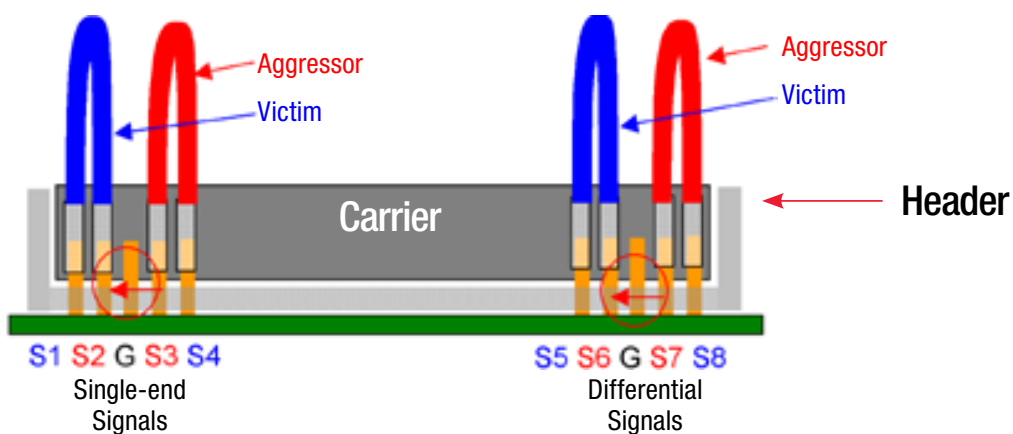

**NOTE:** Example test setups shown above utilize one test board; however, multiple boards may be purchased for board-to-board applications utilizing separate ground planes.

# 5.0 Examples of Test Data for a 3M™ SCI Cable Assembly 2 mm (12 inches) interconnecting two 3M™ Latch/Eject Headers

TDR profiles at various rise times examples...

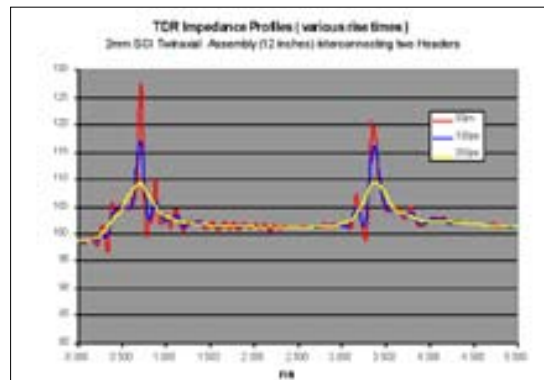
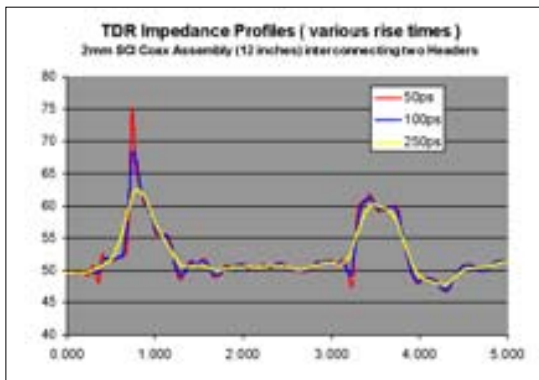

Insertion Loss (S-Parameter) examples...

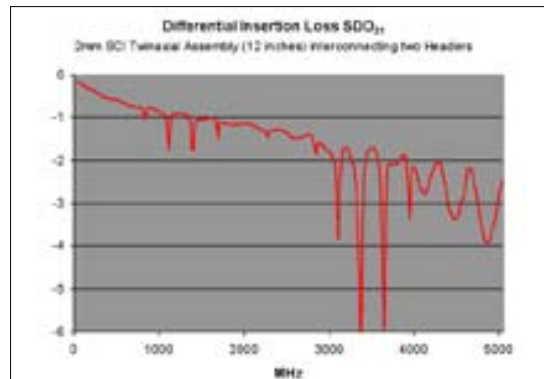
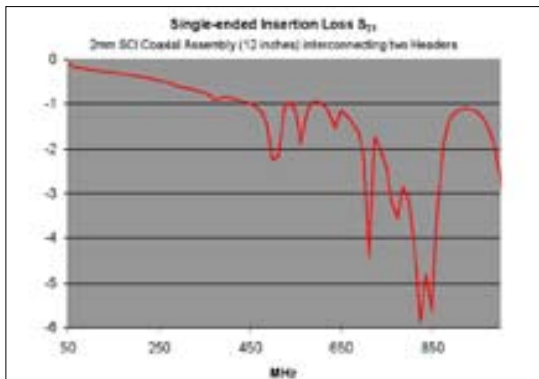

Eye Pattern example...

1Gbps Single-ended (50% eye height)

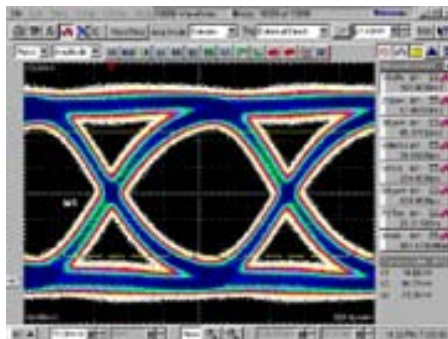

8Gbps Differential (50% eye height)

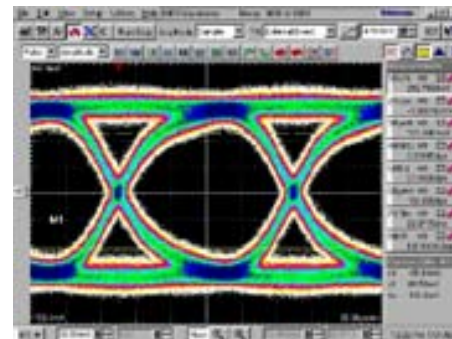



## 6.0 Additional Technical Assistance and Information

Please contact your local 3M Sales or Customer Service Representative if you would like additional assistance from our Signal Integrity Application Engineers.

- Website: [www.3M.com/interconnects](http://www.3M.com/interconnects)
- eTech Service Mailbox: [esd-interconnect-etechservice@mmm.com](mailto:esd-interconnect-etechservice@mmm.com)
- Customer Service: (800) 225-5373
- TS-2199 Data Sheet for 3M™ Latch Eject Header 2 mm
- TS-2105 Data Sheet for 3M™ SCI Cable Assemblies and Carriers 2 mm
- TS-2298 Data Sheet for 3M™ SCI 2 mm Design Kits with test boards, cable assemblies and headers



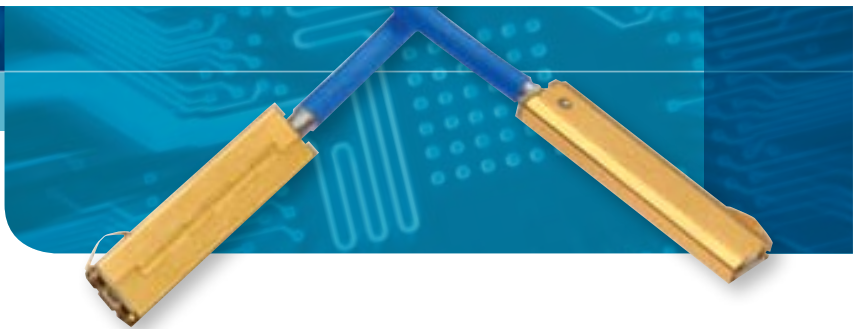

## NOTES

A series of horizontal dotted lines for taking notes.



Note: The test board used in the cover photo is for example only. See contents of this manual for full description of the actual board.

3M is a trademark of 3M Company. All other trademarks are owned by their respective companies.

### **Important Notice**

All statements, technical information, and recommendations related to 3M's products are based on information believed to be reliable, but the accuracy or completeness is not guaranteed. Before using this product, you must evaluate it and determine if it is suitable for your intended application. You assume all risks and liability associated with such use. Any statements related to the product which are not contained in 3M's current publications, or any contrary statements contained on your purchase order shall have no force or effect unless expressly agreed upon, in writing, by an authorized officer of 3M.

### **Warranty; Limited Remedy; Limited Liability.**

3M's product warranty is stated in its Product Literature available upon request. **3M MAKES NO OTHER WARRANTIES INCLUDING, BUT NOT LIMITED TO, ANY IMPLIED WARRANTY OF MERCHANTABILITY OR FITNESS FOR A PARTICULAR PURPOSE.** If this product is defective within the warranty period stated above, your exclusive remedy shall be, at 3M's option, to replace or repair the 3M product or refund the purchase price of the 3M product. **Except where prohibited by law, 3M will not be liable for any indirect, special, incidental or consequential loss or damage arising from this 3M product, regardless of the legal theory asserted.**



### **Electronic Solutions Division Interconnect Products**

6801 River Place Blvd.  
Austin, TX 78726-9000  
1-800-225-5373  
[www.3M.com/interconnects](http://www.3M.com/interconnects)

Please recycle. Printed in U.S.A.  
© 3M 2009. All rights reserved.  
78-9100-7516-3A