



Product Facts

- High current handling capability: 31 or 53 amperes maximum depending on application (reference product specs)
- Modular housings for multiple connector applications
- Assortment of mounting accessories available
- Interlock between adjacent housings to assist assembly
- Precision formed contacts available in strip form for high-speed automatic machine application or loose piece for hand tool application
- Integral stainless steel locking spring in housing for contact retention and reliable contact performance
- Choice of silver or gold plated copper contacts
- Housing of impact resistant thermoplastic
- Accepts wire size range 18–6 AWG [0.8-15 mm²]
- Positive electrical continuity provided by self-cleaning wiping action of mated contacts
- Recognized under the Component Program of Underwriters Laboratories Inc., File No. E-28476 
- Certified by Canadian Standards Association, File No. LR 7189 



AMP Power Lock Connectors have hermaphroditic housing and contact designs. The hermaphroditic housings are also modular in design and permit the clustering of connectors of the same series. Housings are made of impact resistant thermoplastic with stainless steel locking springs for contact stability. Terminals are available in strip and loose piece form with a material choice of silver, or gold plated copper. Contacts for Series I Connectors accept a wire size range of 18–12 AWG [0.8-3 mm²] and contacts for Series II Connectors accept a wire size range of 10–6 AWG [6-15 mm²].

Both insert easily into housings where integral locking springs provide positive retention.

AMP Power Lock Connectors can be adapted to most high current applications and may be used as free-hanging, surface mounted and thru-panel mounted connectors, or when posted contacts are used, they can be used on printed circuits.

Precision formed contacts are available in strip form for automatic machine application, providing maximum production and minimum assembly time.

Technical Documents:

Product Specifications

108-11026 Series I
108-11043 Series II

Instruction Sheets

408-2624 Series I Housings
408-2928 Series I Contacts
408-2597 Series II Housings
408-3196 Series II Contacts

Application Specification

114-6032 Series II

For complete product information, order Catalog 65864

Series I Connectors

Contacts

Material:

Contact— .035 [.089] copper

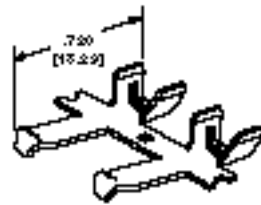

Crimp Contact



Solder Contact

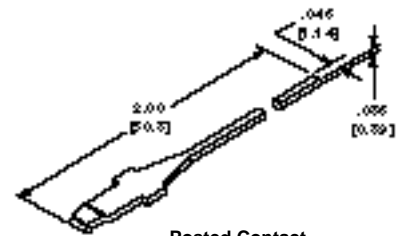

Posted Contact

Type	Wire Range		Plating	Part Numbers	
	AWG	mm ²		Strip Form	Loose Piece
Crimp Contact	18-12	0.8-3	Silver	53892-2	53892-4
			Gold*	53892-8	53892-7
Solder Contact	12Max.	3	Silver	—	54329-1
Posted Contact	—	—	Silver	—	54326-2
			Gold*	—	54326-1

*.000030 [0.00076] gold over .000050 [0.0013] nickel

Single-Circuit Housing Assemblies

Material:

Housing— Polycarbonate

Color	Part Number
White	53894-1
Black	53894-2
Green	53894-3
Red	53894-4
Yellow	53894-5
Blue	53894-6

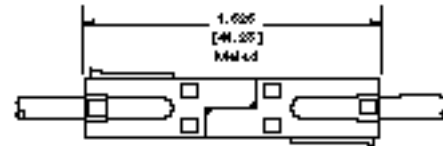
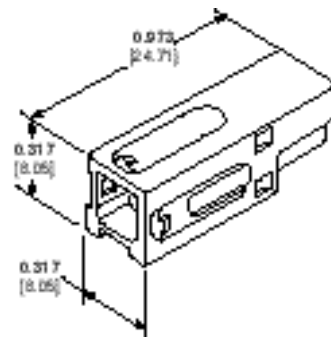

Adapters

Material:

Housing— Polycarbonate, red

Typical Mounting Configuration



Thru-Panel Mount Vertical Mount

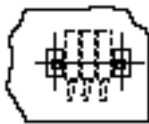

Surface Mount

Spacer

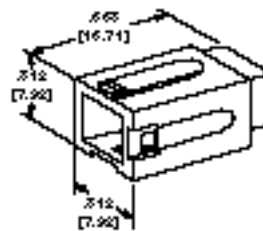

Part Number 53899-2

Mounting Adapter

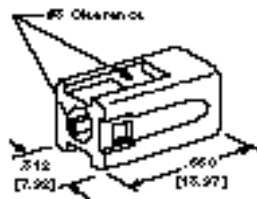

Part Number 54315-1

Key

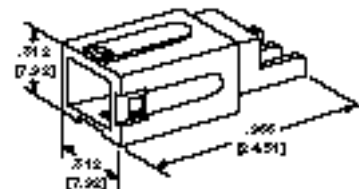

Part Number 53899-1

For complete product information, order Catalog 65864

Series I Connectors

2 to 6 Position In-Line Housings

Material:

Housing — Nylon, natural color

Note: In-Line Housings with and without mounting flanges can be mated with suitably arranged clusters of single-circuit housings found on page 2.

With Mounting Flanges

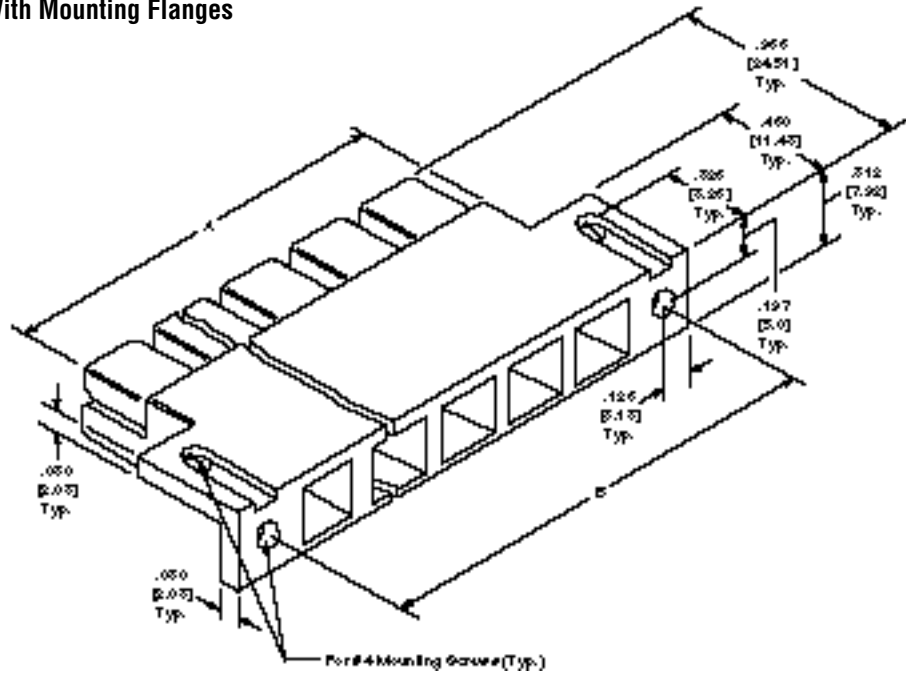

Without Mounting Flanges

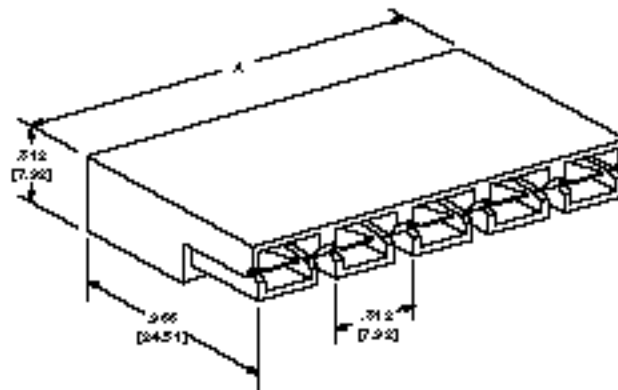

No. of Positions	Dimensions		Part Numbers	
	A	B*	With Flanges	Without Flanges
2	.624 15.85	.874 22.2	54489-2	54483-2
3	.936 23.77	1.186 30.12	54489-3	—
4	1.248 31.7	1.498 38.05	54489-4	54483-4
6	1.872 47.55	2.122 53.9	54489-6	—

*Dimension required only for housing with mounting flanges.

For complete product information, order Catalog 65864

Series II Connectors

Contacts

Material:

Contact — .048 [1.22] copper



Crimp Contact

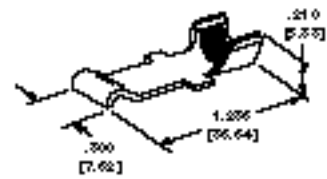

Solder Contact

Type	Wire Range		Plating	Part Numbers Loose Piece
	AWG	mm ²		
Crimp Contact	10-6	6-15	Silver	53880-4
Solder Contact	6 Max.	15	Silver	54330-1

Connector Housing Assembly

Part Numbers 53884-1 blue
53884-3 black
53884-4 red

Material:

Housing — Polycarbonate

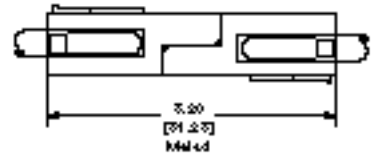
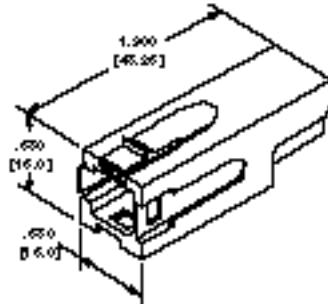

Panel Mounting Adapters

Part Numbers 53886-1 female
53887-1 male

Material:

Housing — Polycarbonate, blue

Mounting Dimensions

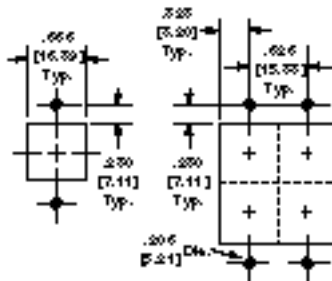

Male Adapter



Part Number 53887-1

Female Adapter

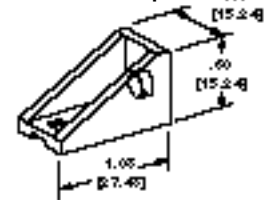

Part Number 53886-1

Surface Mounting Adapter

Part Number 53885-1

Material:

Housing — Polycarbonate, blue

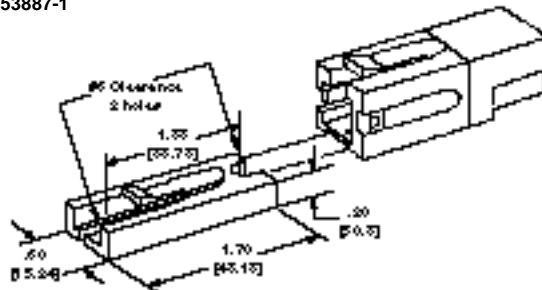

For complete product information, order Catalog 65864

Application Tooling

Series I Connector Tooling

The Series I AMP Power Lock Contact can be terminated in the industry accepted AMP-O-LECTRIC Semiautomatic Terminating Machine. This machine accepts a special side-feed mini-applicator which permits you to "dial-in" the proper crimp height and provides a reliable crimp. The Heavy Head Hand Tool is also available for limited production requirements using loose piece contacts.



Heavy Head Hand Tool
Part Number 68347-1 (Instruction Sheet 408-2734)



AMP-O-LECTRIC Model "G" Terminating Machine
Part Number 354500-1 (Customer Manual 409-5842)

AMPOMATOR CLS IV+ Lead-Making Machine
Part Number 356500-1, -2

Heavy-Duty, Side Feed Miniature Applicators
Part Number 466516-7 for Model "K" Terminating Machine (Applicator Instruction 408-8074)
Part Number 466516-6 for CLS IV+ Lead-Making Machine (Applicator Instruction 408-8074)

Note: Contact Extraction Tool
Part Number 68265-1
May be ordered, if desired.

Series II Connector Tooling

The Semiautomatic Power Applicator is designed to produce a carefully controlled uniform pressure crimp while providing a high rate of production. The applicator features matching dies that fully bottom at the completion of the crimp to provide proper crimp height. The one die set is fully adjustable to provide the full range of crimp heights for all wire sizes.

For limited applications the BANTAM ROTA-CRIMP Hand Tool produces the same uniform crimp.



BANTAM ROTA-CRIMP Hand Tool
Part Number 68321-1 (Instruction Sheet 408-2681)

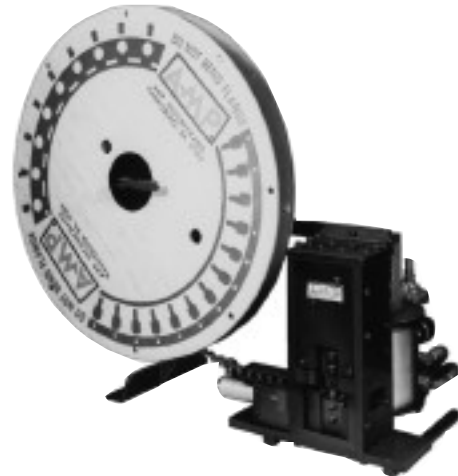

Power Applicator
Part Number 68296-1 (Customer Manual 409-2661)

For complete product information, order Catalog 65864