

REVISION C

DESIGNED & DIMENSIONED
IN MILLIMETERS [INCHES]

DCA-17-XX

- STYLE
 -01: PANEL MOUNT DUST CAP
 -02: CABLE DUST CAP
 -03: USB FLASH DRIVE COVER

DO NOT
SCALE FROM
THIS PRINT

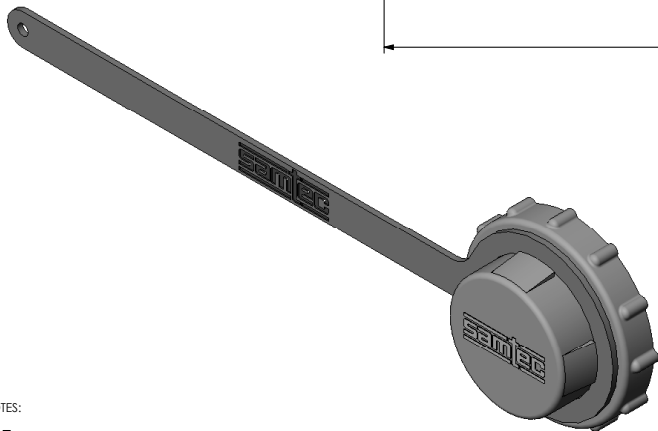
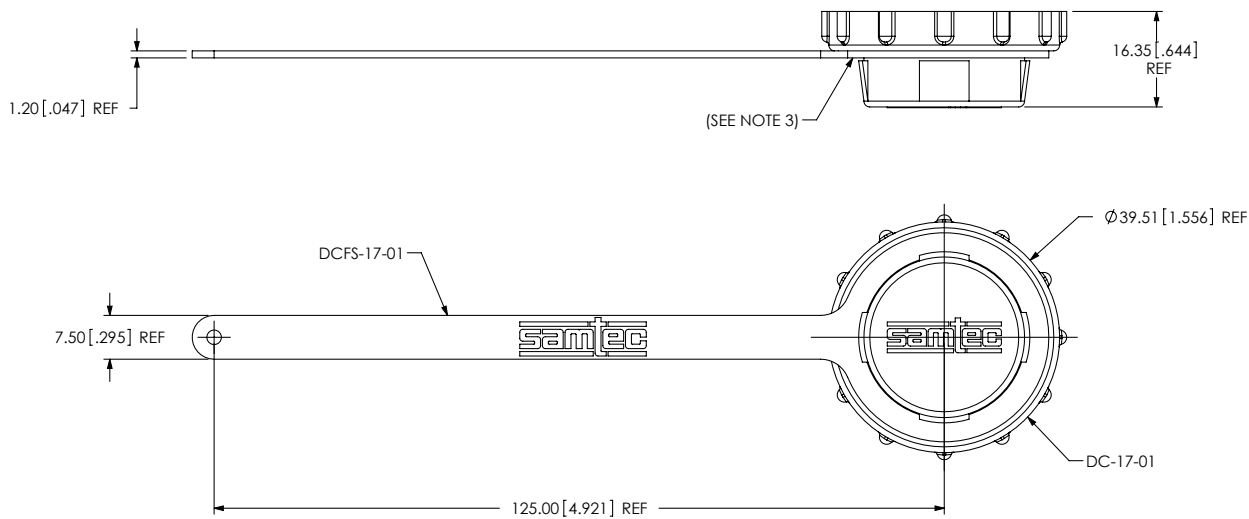

FIG. 1
DCA-17-01 SHOWN

NOTES:

1. ⊗ REPRESENTS A CRITICAL DIMENSION.
2. VENDOR TO ASSEMBLE PARTS.
3. COMPONENTS MUST BE PRESSED DOWN BELOW SNAPS.
4. DCA-17-03 WILL ACCOMMODATE USB DEVICE WITH DIMENSIONS 80.00mm X 13.30mm X 20.25mm.
5. TORQUE SPECIFICATION FOR SCN-17-04 IS 12 IN-LB.

UNLESS OTHERWISE SPECIFIED, DIMENSIONS ARE IN MILLIMETERS. TOLERANCES ARE: DECIMALS ANGLES .X: $\pm 0.3 [0.1]$ 2 * .XX: $\pm 0.13 [0.05]$.XXX: $\pm 0.051 [0.020]$	PROPRIETARY NOTE THIS DOCUMENT CONTAINS INFORMATION CONFIDENTIAL AND PROPRIETARY TO SAMTEC, INC. AND SHALL NOT BE REPRODUCED OR TRANSFERRED TO OTHER DOCUMENTS OR DISCLOSED TO OTHERS OR USED FOR ANY PURPOSE OTHER THAN THAT WHICH IT WAS OBTAINED WITHOUT THE EXPRESSED WRITTEN CONSENT OF SAMTEC, INC.	DESCRIPTION: DUST CAP ASSEMBLY	
		DWG. NO. DCA-17-XX	
MATERIAL: DO NOT SCALE DRAWING SHEET SCALE: 1:1 STRAP: LDPE CAP: PA66 O-RING: SILICONE		BY: CHAD F 11/22/2004	SHEET 1 OF 3



520 PARK EAST BLVD, NEW ALBANY, IN 47150
 PHONE: 812-944-6733 FAX: 812-948-5047
 e-Mail: info@SAMTEC.com code: 55322

c:\enterprise\vauf\DWG\MISC\MKTG\DCA-17-XX-MKT.SLDRW

REVISION C

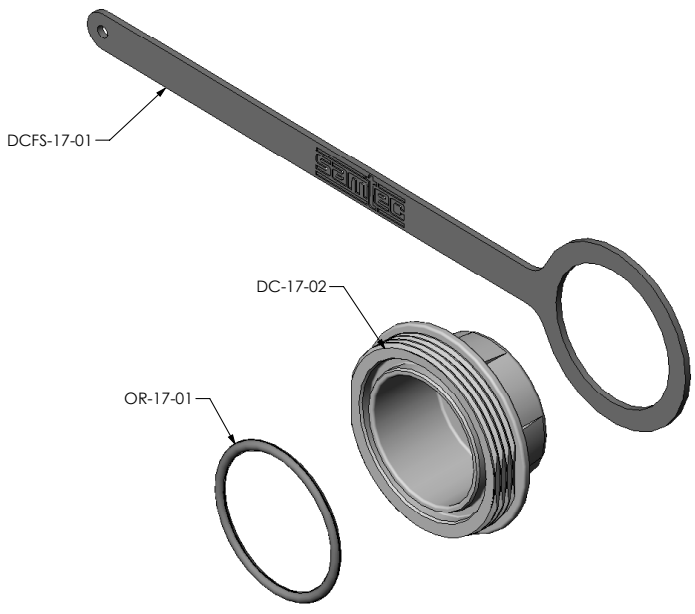
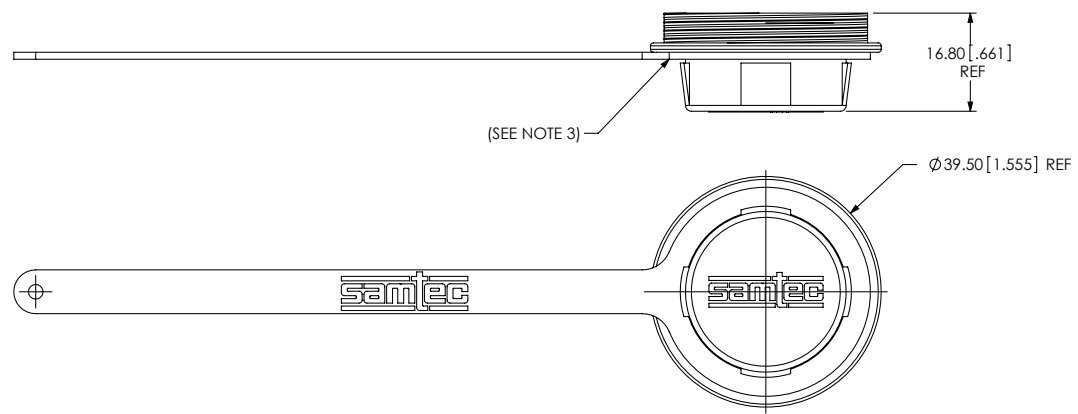



FIG. 2
DCA-17-02 SHOWN
(SAME AS FIG. 1, UNLESS OTHERWISE STATED)

PROPRIETARY NOTE
THIS DOCUMENT CONTAINS INFORMATION
CONFIDENTIAL AND PROPRIETARY TO
SAMTEC, INC. AND SHALL NOT BE REPRODUCED
OR TRANSFERRED TO OTHER DOCUMENTS OR
DISCLOSED TO OTHERS OR USED FOR ANY
PURPOSE OTHER THAN THAT WHICH IT WAS
OBTAINED WITHOUT THE EXPRESSED WRITTEN
CONSENT OF SAMTEC, INC.

DO NOT SCALE DRAWING

SHEET SCALE: 1:1

 520 PARK EAST BLVD, NEW ALBANY, IN 47150 PHONE: 812-944-6733 FAX: 812-948-5047 e-Mail: info@SAMTEC.com code: 55322	
DESCRIPTION:	DUST CAP ASSEMBLY
DWG. NO.	DCA-17-XX
BY: CHAD F	11/22/2004 SHEET 2 OF 3

c:\enterprisevault\DWG\MISC\MKTG\DCA-17-XX-MKT.SLDDRW

REVISION C

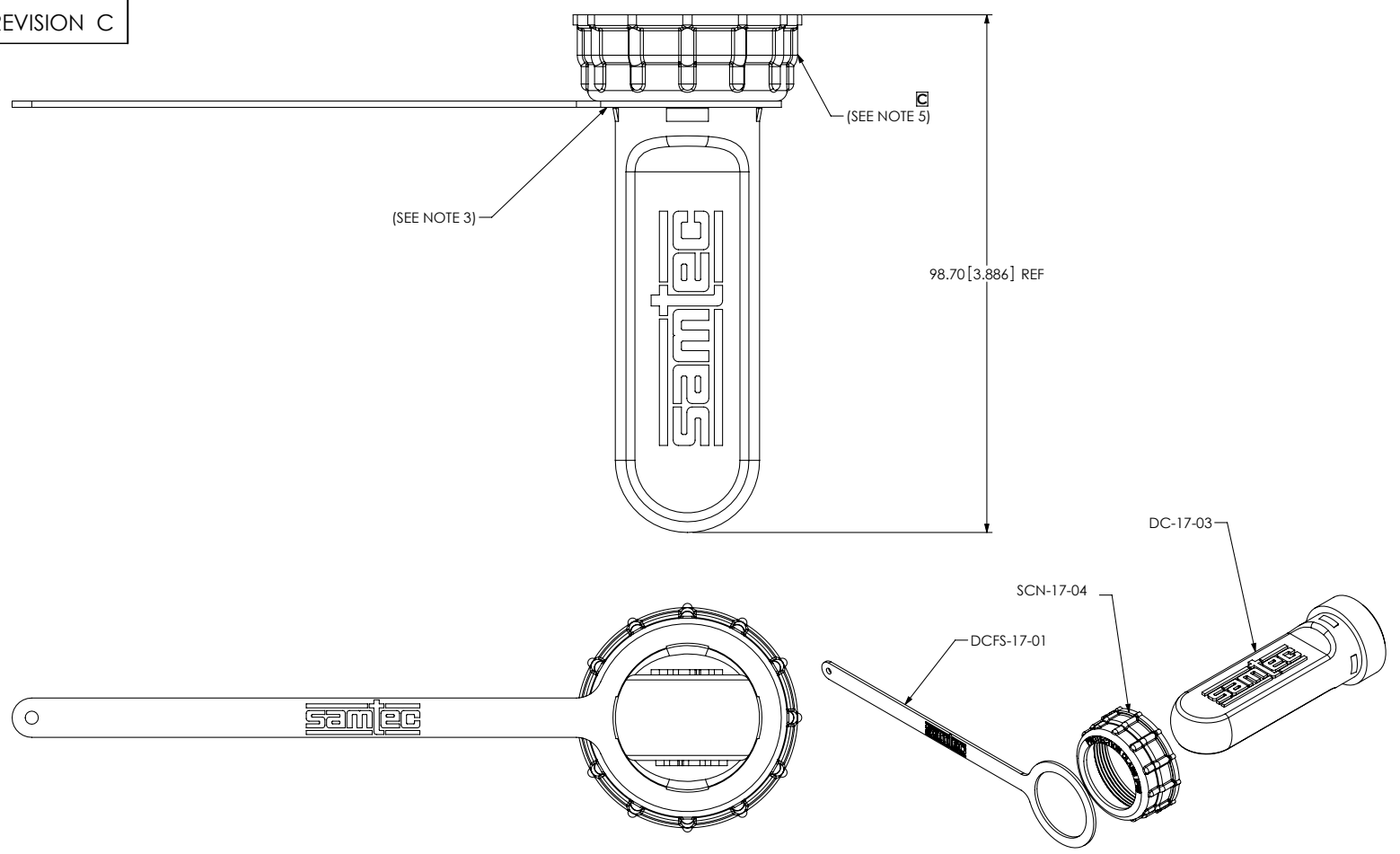



FIG. 3
DCA-17-03 SHOWN
(SAME AS FIG. 1, UNLESS OTHERWISE STATED)

PROPRIETARY NOTE
THIS DOCUMENT CONTAINS INFORMATION
CONFIDENTIAL AND PROPRIETARY TO
SAMTEC, INC. AND SHALL NOT BE REPRODUCED
OR TRANSFERRED TO OTHER DOCUMENTS OR
DISCLOSED TO OTHERS OR USED FOR ANY
PURPOSE OTHER THAN THAT WHICH IT WAS
OBTAINED WITHOUT THE EXPRESSED WRITTEN
CONSENT OF SAMTEC, INC.

DO NOT SCALE DRAWING

SHEET SCALE: 1:2

 520 PARK EAST BLVD, NEW ALBANY, IN 47150 PHONE: 812-944-6733 FAX: 812-948-5047 e-Mail: info@SAMTEC.com code: 55322	
DESCRIPTION:	DUST CAP ASSEMBLY
DWG. NO.	DCA-17-XX
BY: CHAD F	11/22/2004 SHEET 3 OF 3

c:\enterprisevault\DWG\MISC\MKTG\DCA-17-XX-MKT.SLDDRW