

TOOL NUMBER	WIRE SIZE mm ² [AWG]	INSULATION DIAMETER mm [in.]	STRIP LENGTH mm [in.]	CRIMP HEIGHT mm [in.]	CONTACT PART NUMBERS Δ		CONTACT DESCRIPTION	APPLICATION SPECIFICATION
					LOOSE PIECE	STRIP FORM		
91563-1 91563-3	0.20-0.56 [24-20]	150-2.20 [.059-.087]	4.0-4.5 [.157-.177]	0.98±0.05 [.039±.002]	171699-[] Δ	171630-[] Δ Δ	ECONOSEAL "J" II, .070 Series Contacts	114-5082
	0.20-0.56 [24-20]			1.02±0.05 [.040±.002]	173600-[] Δ	171631-[] Δ Δ		
91573-1 91573-3	0.50-0.89 [20-18]	2.00-2.60 [.079-.102]	3.5-4.5 [.138-.177]	1.20-1.35 [.047-.053]	175027-[] Δ	173631-[] Δ Δ	.070 Series Contacts	114-5091 114-5092 114-5091-9 114-5092-9
	1.25-1.42 [16]			1.45-1.60 [.057-.063]	175030-[] Δ	173645-[] Δ Δ		
91580-1 91580-3	0.20-0.22 [24]	120-1.50 [.047-.059]	3.5-4.5 [.138-.177]	1.00-1.10 [.039-.043]	175026-[] Δ	173630-[] Δ Δ	.070 Series Contacts	114-5091 114-5092 114-5091-9 114-5092-9
	0.30-0.35 [22]	120-1.60 [.047-.063]		1.05-1.18 [.041-.046]	175029-[] Δ	173633-[] Δ Δ		
91583-1 91583-3	0.50-0.89 [20-18]	2.00-2.70 [.079-.106]	4.5-5.0 [.177-.197]	1.20-1.32 [.047-.0512]	173707-[] Δ Δ	171662-[] Δ Δ Δ	ECONOSEAL "J" II, .070 Series Contacts	114-5082
	1.25-1.42 [16]			1.38-1.52 [.054-.060]				
91585-1 91585-3	0.50-0.89 [20-18]	2.00-2.70 [.079-.106]	4.5-5.0 [.177-.197]	1.20-1.32 [.047-.0512]	173706-[] Δ Δ	171661-[] Δ Δ Δ	ECONOSEAL "J" II, .070 Series Contacts	114-5082
	1.25-1.42 [16]			1.38-1.52 [.054-.060]				

Δ LIST OF APPLIED CONTACT PART NUMBERS MAY NOT BE COMPLETE AND IS SUBJECT TO CHANGE. FOR CURRENT INFORMATION ON TERMINAL PART NUMBERS, CONTACT THE TOOLING ASSISTANCE CENTER : 1-800-722-1111.

2. AMP, CERTI-CRIMP and ECONOSEAL ARE TRADEMARKS.

Δ TERMINAL MUST BE PRE-FORMED BEFORE IT CAN BE CRIMPED.

Δ .070 TYPE RUBBER PLUG 172746-[] OR 178210-[] IS USED WHEN CRIMPING THIS PRODUCT.

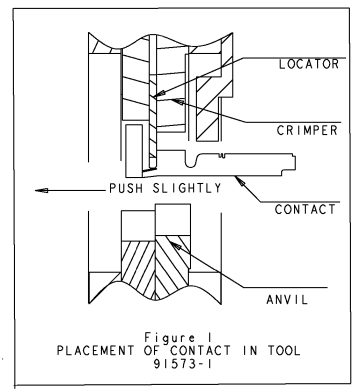

Δ .070 TYPE RUBBER PLUG 176886-[] OR 172888-[] IS USED WHEN CRIMPING THIS PRODUCT.



Δ POSITION CONTACT BETWEEN CRIMPS SO LOCATOR / INSULATION STOP ENTERS THE CONTACT. PUSH THE CONTACT TOWARD THE LOCATOR AS SHOWN IN FIGURE 1. HOLDING CONTACT IN PLACE, SQUEEZE TOOL HANDLES TOGETHER UNTIL INSULATION BARREL ANVIL STARTS ENTRY INTO INSULATION CRIMPER. DO NOT DEFORM INSULATION BARREL OR WIRE BARREL AT THIS MOMENT.

Δ -1 IS A COMPLETE CERTI-CRIMP II HAND TOOL ASSEMBLY.
-3 IS A CERTI-CRIMP II HEAD SUB-ASSEMBLY.

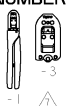
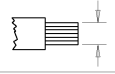
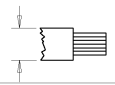
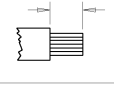
<small>THIS DRAWING IS UNPUBLISHED. RELEASED FOR PUBLICATION. ALL RIGHTS RESERVED.</small>		DATE: 19FEB2002 CHN: GULA 19FEB2002 APP: B. SCHAEFFER 19FEB2002	AMP Tyco Electronics Harrisburg, PA 17105-3600
DIMENSIONS: mm 0 PLC 1 PLC 2 PLC 3 PLC 4 PLC ANGLE: 90° FINISH:	DIMENSIONS: mm 0 PLC 1 PLC 2 PLC 3 PLC 4 PLC ANGLE: 90° FINISH:	TITLE: CERTI-CRIMP II TOOL DATA SHEET ECONOSEAL "J" II & .070 SERIES CONTACTS DRAWING NO: A2 00779 SCALE: 1:1 SHEET: 1 OF 2 REV: B2	CUSTOMER DRAWING

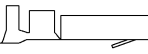
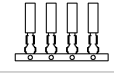
TOOL NUMBER 	WIRE SIZE mm ² [AWG] 	INSULATION DIAMETER mm [in.] 	STRIP LENGTH mm [in.] 	CRIMP HEIGHT mm [in.] 	CONTACT PART NUMBERS Δ		CONTACT DESCRIPTION	APPLICATION SPECIFICATION
					LOOSE PIECE 	STRIP FORM 		
1752959-1 1752959-3	128-142 [16] 194-215 [14]	2.08-2.64 [082-104]	3.60-4.20 [142-165]	142±0.05 [056±0.02] 160±0.05 [063±0.02]	-	1-1437709-3 1-1437709-6	16 MM SYSTEM TERMINAL W/SEAL	N/A
1752960-1 1752960-3	0.50-0.60 [20] 0.81-0.96 [18]	1.40-2.21 [055-087]	3.60-4.20 [142-165]	107±0.05 [042±0.02] 119±0.05 [047±0.02]	-	1-1437709-2 1-1437709-5	16 MM SYSTEM TERMINAL W/SEAL	N/A
-	-	-	-	-	-	-	-	-
-	-	-	-	-	-	-	-	-
-	-	-	-	-	-	-	-	-

<small>THIS DRAWING IS UNPUBLISHED. RELEASED FOR PUBLICATION. ALL RIGHTS RESERVED. ORGANIZATION SHOULD BE CONTACTED FOR THE LATEST REVISION.</small>		DWG: J GULA 19FEB2002 CHN: J GULA 19FEB2002 APPR: B SCHAEFFER 19FEB2002	AMP Tyco Electronics Harrisburg, PA 17105-3400
DIMENSIONS: mm 	DIMENSIONS: INCHES OPERATING SPECIFICATIONS 0 PLC - 1 PLC - 2 PLC - 3 PLC - 4 PLC - ANGLES - FINISH -	PRODUCT SPEC - APPLICATION SPEC - WEIGHT - CUSTOMER DRAWING	TITLE: A2 00779 CASE CODE: 1583009 DRAWING NO: 1583009 SCALE: - SHEET: 2 OF 2 REV: B2