

LOC	DIST	REVISIONS					
GP	00	P	LTR	DESCRIPTION	DATE	DWN	APVD
		0		REL. AS PER EC 0S13-0288-05	10AUG05	BL	JG

1. MATERIAL: ZINC PLATED STEEL.
2. ALL DIMENSIONS SHOWN ARE FOR REFERENCE ONLY UNLESS OTHERWISE SPECIFIED.

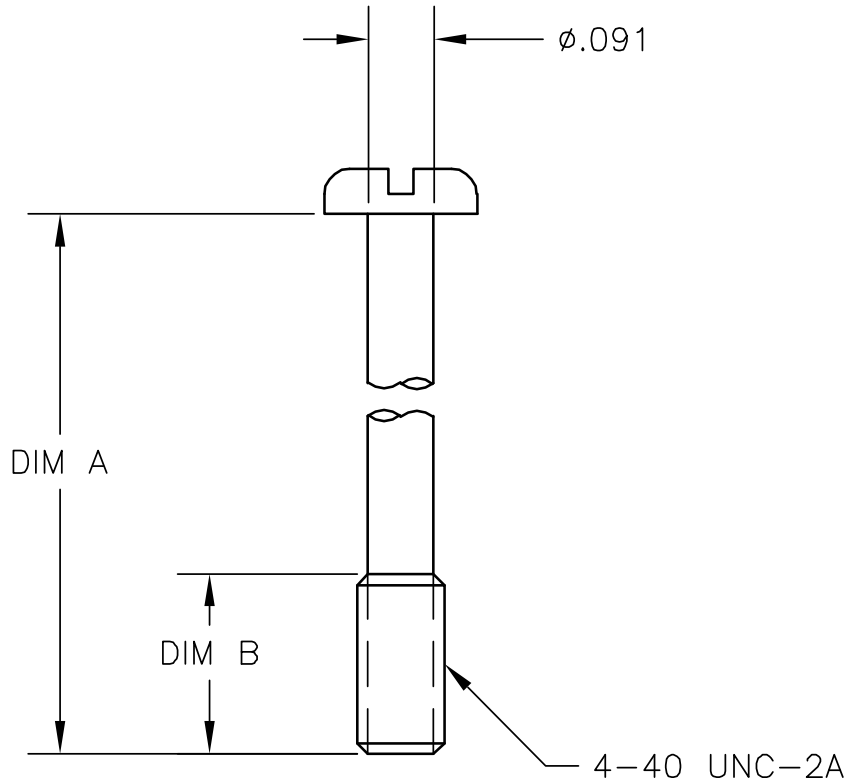

.100	.265	5229996-4
.100	.350	5229996-3
.100	.425	5229996-2
DIM B	DIM A	PART NO

THIS DRAWING IS UNPUBLISHED. ALL RIGHTS RESERVED. BY TYCO ELECTRONICS CORPORATION.

DIMENSIONS: INCHES		DWN B. LATTUCA 10AUG05	MATERIAL 	FINISH -
TOLERANCES UNLESS OTHERWISE SPECIFIED:		CHK J. GERACE 10AUG05	Tyco Electronics Corporation Harrisburg, Pa 17105-3608	
0 PLC ± - 1 PLC ± - 2 PLC ± - 3 PLC ± .005 4 PLC ± - ANGLES ± -		APVD M. WALMSLEY 10AUG05	NAME SCREW, PAN HD, CAPTIVE	
		PRODUCT SPEC -	SIZE A4	CAGE CODE 00779
		APPLICATION SPEC -	DRAWING NO C-5229996	RESTRICTED TO -
		WEIGHT -		
CUSTOMER DRAWING			SCALE 4:1	SHEET 1 OF 1
			REV 0	