

**CERTI-CRIMP II SAHT**

Standard Straight Action Hand Tool Design  
Widely used in the Aircraft and Military industries

*Image representative of type only*

**Features:**

Fixed dies  
Straight action jaw closure  
Ratchet mechanism ensures complete crimp cycle  
Emergency only ratchet release  
Terminal/wire positioning aids & Ins. adjustment on most tools  
Ergonomic non-slip handles  
Approximate weight 0.59 kg (1.3 lbs)



Part Number	Description	mm <sup>2</sup> (AWG) or other
91572-1	AMP CT 2.0 Receptacle	0.12 - 0.4 (26-22)
91576-1	AMP DYNAMIC D-2	0.08 - 0.22 (28-24)
91595-1	AMP DYNAMIC D-2	0.4 - 1.0 (22-18)
91559-1	AMP DYNAMIC D-3	0.2 - 0.6 (24-20)
91558-1	AMP DYNAMIC D-3	0.6 - 1.5 (20-16)
91549-1	AMPLIMITE HD-20	0.08 - 0.22 (28-24)
91503-1	AMPLIMITE HD-20	0.08 - 0.6 (28-20)
91548-1	AMPLIMITE HD-20	0.08 - 0.6 (28-20) No Ins. Crimp
91525-1	AMPLIMITE HD-20	0.15 - 0.4 (26-22)
91513-1	AMPLIMITE HD-20	0.4 - 1.0 (22-18) No Ins. Crimp
91520-1	AMPLIMITE HD-22	0.08 - 0.4 (28-22)
91537-1	AMPMODU II FFC	0.15 - 0.4 (26-22)
91516-1	AMPMODU IV	0.05 - 0.6 (30-20)
91517-1	AMPMODU IV, V	0.15 - 0.4 (26-22)
91512-1	Commercial MATE-N-LOK	0.2 - 0.96 (24-18) Ins. Ø1.52-2.54mm
91504-1	Commercial MATE-N-LOK	0.6 - 2.5 (20-14)
1901963-1	MATE-N-LOK 3.5 (.140)	0.5 - 2.1 (20-14)
91502-1	Micro MATE-N-LOK	0.05 - 0.12 (30-26)
91501-1	Micro MATE-N-LOK	0.2 - 0.6 (24-20)
91540-1	Mini Tandem-Spring Pin	0.03 - 0.4 (32-22)
91536-1	Mini-Universal MATE-N-LOK "F" Ins. Crimp	[20-16]
91529-1	Mini-Universal MATE-N-LOK	0.15 - 0.4 (26-22)
91522-1	Mini-Universal MATE-N-LOK	0.4 - 1.0 (22-18)
91594-1	Mini-Universal MATE-N-LOK, type "O" Ins. Crimp	0.5 - 1.42 (20-16)
91577-1	MULTILOCK 040	0.4 - 0.6 (22-20)
91588-1	MULTILOCK 040 MkII	0.6 - 1.0 (20-18)
91542-1	TYPE III+	0.2 - 0.6 (24-20)
91505-1	TYPE III+	0.2 - 1.42 (24-16) Ins. Ø1.14-2.54mm
91523-1	TYPE III+	0.2 - 1.5 (24-16) Ins. Ø2.03-2.54mm
91521-1	TYPE III+	1.0 - 2.5 (18-14)
91515-1	TYPE III+; Type VI; Commercial MATE-N-LOK	0.05 - 0.6 (30-20)
91510-1	Universal MATE-N-LOK	0.2 - 0.96 (24-18)
91506-1	Universal MATE-N-LOK	1.2 - 2.1 (16-14) Ins. Ø3.30-5.08mm

*Only the most popular options are listed here, please use our online search by terminal PN to find the right tool for your application, and contact us where information is unclear or missing - there may well be something available for your requirement.*

## CERTI-CRIMP II SAHT - Short Handle

Ideal for working in confined spaces  
Widely used in the Aircraft and Military industries

*Image representative of type only*

### Features:

- Fixed dies
- Straight action jaw closure
- Ratchet mechanism ensures complete crimp cycle
- Emergency only ratchet release
- Terminal/wire positioning aids & Ins. adjustment on most tools
- Ergonomic non-slip handles
- Approximate weight 0.5 kg (1.1 lbs)



Part Number	Description	mm <sup>2</sup> (AWG) or other
1901611-2	PIDG STRATO-THERM Terminals & Splices	0.2 - 0.6 (24-20)
1901600-2	PIDG STRATO-THERM Terminals & Splices	1.0 - 1.5 (18-16)

*Only the most popular options are listed here, please use our online search by terminal PN to find the right tool for your application, and contact us where information is unclear or missing - there may well be something available for your requirement.*

## CERTI-CRIMP II SAHT - Long Handle

Low handle force for ease of operation  
Widely used in the Aircraft and Military industries

*Image representative of type only*

### Features:

- Fixed dies
- Straight action jaw closure
- Ratchet mechanism ensures complete crimp cycle
- Emergency only ratchet release
- Terminal/wire positioning aids & Ins. adjustment on most tools
- Ergonomic non-slip handles
- Approximate weight 0.59 kg (1.3 lbs)



Part Number	Description	mm <sup>2</sup> (AWG) or other
1901611-1	PIDG STRATO-THERM Terminals & Splices	0.2 - 0.6 (24-20)
1901600-1	PIDG STRATO-THERM Terminals & Splices	1.0 - 1.5 (18-16)

*Only the most popular options are listed here, please use our online search by terminal PN to find the right tool for your application, and contact us where information is unclear or missing - there may well be something available for your requirement.*

## CERTI-CRIMP II SAHT - Head Assy (Square)

Head only for use with Power Assist options

*Image representative of type only*

### Features:

- Fixed Dies
- Straight action jaw closure
- Ratchet mechanism ensures complete crimp cycle
- Emergency only ratchet release
- Terminal/wire positioning aids & Ins. adjustment on most tools

Use with:

- 1213805-[ ] Battery Tool Kit
- 1213860-[ ] Adapter, Electric Terminator

Part Number	Description	mm <sup>2</sup> (AWG) or other
1-1901611-1	PIDG STRATO-THERM Terminals & Splices	0.2 - 0.6 (24-20)
1-1901600-2	PIDG STRATO-THERM Terminals & Splices	1.0 - 1.5 (18-16)

*Only the most popular options are listed here, please use our online search by terminal PN to find the right tool for your application, and contact us where information is unclear or missing - there may well be something available for your requirement.*

## CERTI-CRIMP II SA Battery Tool Kit

Convert your existing Hand Tools into Powered!

- 1213805-2 - Kit only without Head
- 1213805-5 - Kit only without Head (GB Power Plug)

*Image representative of type only*

### Features:

Heads can be removed from Hand Tools, or are also available as a [-3] option.  
 Example 91500-1 CERTI-CRIMP II SAHT; handles can be removed and the head used with this kit. Alternatively 91500-3 (head only) is also available.

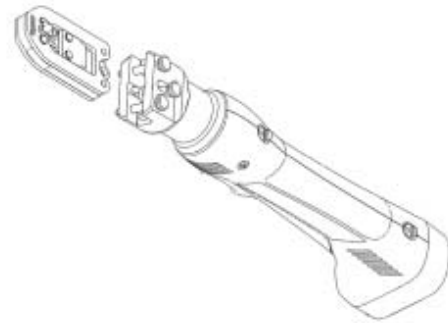

Over 100 crimps per charge  
 Compact - only 360mm (14") long and weighs 1.57kg (3.48lbs)

The Tool Kit is supplied in a durable plastic carry case and includes:  
 Battery Tool with the relevant CERTI-CRIMP II SAHT Adapter  
 Battery Charger 230 v  
 Two Batteries

for more information, please see the Power Assist section

## Adapter - CERTI-CRIMP II to Electric Terminator

1213860-1 - Adapter only

### Features:

For use with Electric Terminator 539630-1 and any CERTI-CRIMP II SAHT Head.

*Image representative of type only*

Heads can be removed from Hand Tools, or are also available as a [-3] option.  
 Example 91500-1 CERTI-CRIMP II SAHT; the head can be removed from the handles and used along with this adapter on the Electric Terminator. Alternatively 91500-3 (head only) is also available.



## Double Action Hand Tool

Note: The approvals shown against the tools listed are only applicable when using terminals and wires recommended for the relevant industry.  
Widely used in Aircraft and Military applications

*Image representative of type only*

### Features:

- Fixed dies
- Ratchet mechanism ensures complete crimp cycle
- Emergency only ratchet release
- Terminal/wire positioning aids & Ins. adjustment on many tools
- Ergonomic non-slip handles
- Approximate weight 0.54 kg (1.2 lbs)



Part Number	Description	mm <sup>2</sup> (AWG) or other
45216	PIDG Closed End Splice	1.0 - 1.5 (18-16)
47386	PIDG & PLASTI-GRIP Terminals; PIDG Splices Standard tool for GB Railways - Qualified; Mil-T-7928/7; LUL RSE 024 pt6 & EE6161 Marks the applied product with a one dot indent code.	0.4 - 1.5 (22-16)
47386-5	PIDG & PLASTI-GRIP Terminals; PIDG Splices French Special - Qualified; Mil-T-7928 - AMP specified level Marks the applied product with a one dot indent code. Includes French Instruction Sheet	0.4 - 1.5 (22-16)
47387	PIDG & PLASTI-GRIP Terminals; PIDG Splices Standard tool for GB Railways - Qualified; Mil-T-7928; LUL RSE 024 pt6 & EE6161 Marks the applied product with a two dot indent code.	1.25 - 2.0 (16-14) 0.6 - 1.5 (20-16) HD
47386-4	PIDG & PLASTI-GRIP Terminals; PIDG Splices & FASTON EMEA Special - Qualified; Mil-T-7928 - AMP specified level for Ringtongues only Marks the applied product with a one dot indent code.	0.4 - 1.5 (22-16)
47387-7	PIDG & PLASTI-GRIP Terminals; PIDG Splices & FASTON EMEA Special - Qualified; Mil-T-7928 - AMP specified level for Ring Tongues only Marks the applied product with a two dot indent code.	1.5 - 2.5 (16-14) 0.6 - 1.5 (20-16) HD
90035-3	PIDG FASTON - Special GB Railways Tool Qualified; LUL RSE 024 pt6 & EE6161	0.4 - 1.0 (22-18)
90009-8	PIDG FASTON - Special GB Railways Tool Qualified; LUL RSE 024 pt6 & EE6161	1.5 - 2.5 (16-14)
482930-1	Special French tool for PIDG FASTON 2.8 (.110) with crimp orientation at 90° Marks the applied product with a one dot indent code.	0.15 - 0.4 (26-22)
47907-1	PIDG Terminals & Splices	0.2 - 0.56 (24-20)
46121	PIDG Terminals & Splices; PLASTI-GRIP Butt Splices Marks the applied product with a one dot indent code	0.15 - 0.4 (26-22)
47304	PIDG Terminals & Splices; PLASTI-GRIP Butt Splices for thin wall insulation Marks the applied product with a one dot indent code	0.15 - 0.4 (26-22)
525690	Special GB Aerospace PIDG & PLASTI-GRIP Ring Tongue Tool. Equivalent to 47386 but has special retaining pins/rings to reduce the risk of tool parts falling off whilst building and maintaining aircraft.	0.6 - 1.0 (20-18)
525691	Special GB Aerospace PIDG & PLASTI-GRIP Ring Tongue Tool. Equivalent to 47387 but has special retaining pins/rings to reduce the risk of tool parts falling off whilst building and maintaining aircraft.	1.25 - 2.0 (16-14)
69363	SOLISTRAND Terminals & Splices - Standard Tool. Qualified; Mil-T-7928; LUL RSE 024 pt6 & EE6161	0.15 - 0.6 (26-20)
49935	SOLISTRAND Terminals & Splices Qualified; Mil-T-7928; LUL RSE 024 pt6 & EE6161	0.4 - 6.0 (22-10)
525693	Special tool for SOLISTRAND Terminals & Splices (GB) Equivalent to 49935 but has special retaining pins/rings to reduce the risk of tool parts falling off whilst building and maintaining aircraft.	0.4 - 6.0 (22-10)
49592	SOLISTRAND Terminals & Splices Qualified; Mil-T-7928; LUL RSE 024 pt6 & EE6161	2.5 - 4.0 (14-12)
46447	SOLISTRAND STRATO-THERM High Temp & Heat Resistant Terminals & Splices	0.4 - 6.0 (22-10)
46673	STRATO-THERM Uninsulated Terminals & Splices	0.4 - 1.5 (22-16)
46673-1	STRATO-THERM Uninsulated Terminals & Splices [thin wall cable]	0.4 - 1.5 (22-16)

*Only the most popular options are listed here, please use our online search by terminal PN to find the right tool for your application, and contact us where information is unclear or missing - there may well be something available for your requirement.*

## Double Action Hand Tool Battery Tool Kit

Convert your existing Hand Tools into Powered!

1213804-2 - Kit only without Head

1213804-5 - Kit only without Head (GB Power Plug)

*Image representative of type only*

### Features:

Example 47386 DAHT; handles can be removed and the head used with this kit.

Over 100 crimps per charge

Compact - only 360mm (14") long and weighs 1.57kg (3.48lbs)

The Tool Kit is supplied in a durable plastic carry case and includes:

Battery Tool with the relevant DAHT Adapter

Battery Charger 230 v

Two Batteries

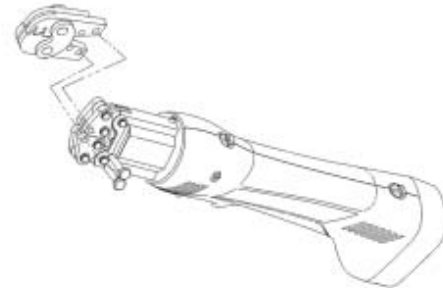

for more information, please see the Power Assist section

## Adapter - Double Action Hand Tool to 626 Pneumatic

1213563-1 - Adapter only

*Image representative of type only*

### Features:

Heads can be removed from Hand Tools, example: the Handles from 47386 can be removed and the head used with this Adapter (includes cam).

Also required:

Hand held power unit 189721-1

or

Foot actuated Power Unit 189722-1

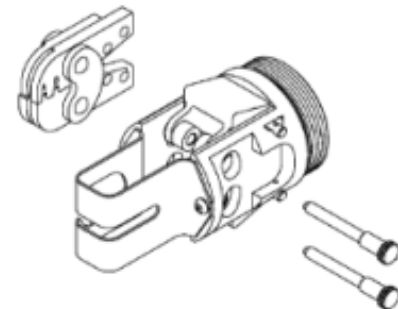

for more information, please see the Power Assist section

## C-Head SAHT

69710-1 - Base Tool without Die-set  
Widely used in Aircraft and Military applications  
Can be used with all C-Head SAHT Dies

*Image representative of type only*

### Features:

Interchangeable Dies  
Straight action jaw closure  
Ratchet mechanism ensures complete crimp cycle  
Emergency only ratchet release  
Approximate weight 0.86 kg (1.9 lbs)



## C-Head SAHT - LD

1901260-1 Base Tool without Die-set  
A light duty alternative to 69710-1  
Can be used with all C-Head SAHT Dies EXCEPT:  
- Die-set - C-Head SAHT - HD  
- Through Splice applicatons

*Image representative of type only*

### Features:

Interchangeable Dies  
Straight action jaw closure  
Ratchet mechanism ensures complete crimp cycle  
Emergency only ratchet release  
Ergonomic non-slip handles  
Approximate weight 0.5 kg (1.1 lbs)



## Die-set - C-Head SAHT

A range of Die-sets for many premium crimp applications

*Image representative of type only*

### Features:

Use in:

Hand Tool Frame 69710-1

Hand Tool Frame 1901260-1 (see restrictions)

Battery Tool Kits:

Open Head 1213840-[ ]

Closed Head 1213819-[ ]

Adapters for C-Head Dies:

Electric Terminator 1901556-1

Press SSC- 2FP 8-1481221-3

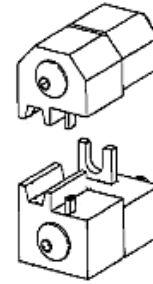

Part Number	Description	mm <sup>2</sup> (AWG) or other
58212-1	AMPLIMITE	RG 142, 142A, 142B
576711	PIDG STRATO-THERM Terminals with PTFE or PEEK for thin-wall Insulation	0.2 - 0.4 (24-22)
576720	PIDG STRATO-THERM Terminals with PTFE or PEEK for thin-wall Insulation	0.5 (22)
576715	PIDG STRATO-THERM Terminals with PTFE or PEEK for thin-wall Insulation	1.0 (18)
576714	PIDG STRATO-THERM Terminals with PTFE or PEEK for thin-wall Insulation	1.5 (16)
47807-1	PIDG, PLASTI-GRIP Terminals & Splices	1.5 - 2.5 (16-14)
47806-2	PIDG, PLASTI-GRIP, Terminals & Splices	0.4 - 1.5 (22-16)
1-539634-9	Pin / Socket size 8	Gore Cable Type: GSC-03-81748-00

*Only the most popular options are listed here, please use our online search by terminal PN to find the right tool for your application, and contact us where information is unclear or missing - there may well be something available for your requirement.*

## Die-set - C-Head SAHT - HD

A range of Heavy Duty Die-sets for many premium crimp applications

*Image representative of type only*

### Features:

Use in:

Hand Tool Frame 69710-1

Adapters for C-Head Dies:

Electric Terminator 1901556-1

Press SSC- 2FP 8-1481221-3

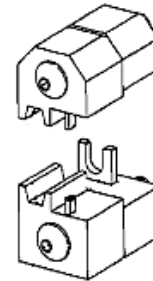

Part Number	Description	mm <sup>2</sup> (AWG) or other
59993-1	AMPLIMITE	8 (10)
69735	PIDG STRATO-THERM Terminals & Splices with PTFE Insulation	4.0 - 6.0 (12-10)
576716	PIDG STRATO-THERM Terminals with PTFE or PEEK for thin-wall Insulation	2.5 (14)
576742	PIDG STRATO-THERM Terminals with PTFE or PEEK for thin-wall Insulation	4.0 (12)
576723	PIDG STRATO-THERM Terminals with PTFE or PEEK for thin-wall Insulation	6.0 (10)
47808-6	PIDG, PLASTI-GRIP Terminals & Splices	4.0 - 6.0 (12-10)
90145-1	TYPE XII Contact	2.5 - 4.0 (14-12)
90140-1	TYPE XII Contact	6.0 - 10.0 (10-8)
58380-1	Universal MATE-N-LOK	3.0 (12)
58380-2	Universal MATE-N-LOK	5.0 (10)

*Only the most popular options are listed here, please use our online search by terminal PN to find the right tool for your application, and contact us where information is unclear or missing - there may well be something available for your requirement.*

## C-Head SAHT Battery Tool Kit

- 1213819-2 - CLOSED head
- 1213819-5 - CLOSED head (GB Power Plug)
- 1213840-2 - OPEN head
- 1213840-5 - OPEN head (GB Power Plug)

*Image representative of type only*

### Features:

- Over 100 crimps per charge
- Compact - only 360mm (14") long and weighs 1.57kg (3.48lbs)

The Tool Kit is supplied in a durable plastic carry case and includes:

- Battery Tool with the relevant C-Head SAHT Adapter
- Battery Charger 230 v
- Two Batteries

for more information, please see the Power Assist section

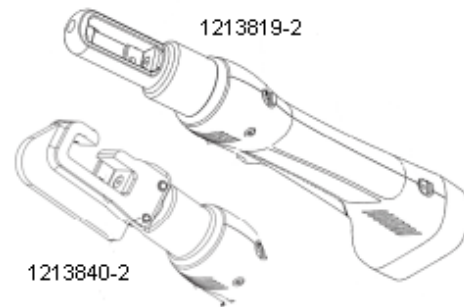

## Adapter - C-Head SAHT to Bench Press SSC-2FP

8-1481221-3 - Adapter only

### Features:

Adapts Bench Top Press SSC- 2FP (1481004-7 pictured) to take C-Head SAHT Dies

for more information on the Press and Press options, please see the Power Assist section

*Image representative of type only*



## Adapter - C-Head SAHT to Electric Terminator

1901556-1 - Adapter only

### Features:

Adapts the Electric Terminator 539630-1 to take C-Head SAHT Dies

for more information on the Press and Press options, please see the Power Assist section

*Image representative of type only*





## Heavy Head Hand Tool

Note: The specifications shown against the tools listed are only applicable when using terminals recommended for the relevant industry  
Widely used in Aircraft and Military applications

*Image representative of type only*

### Features:

Fixed dies  
Straight action jaw closure  
Ratchet mechanism ensures complete crimp cycle  
Emergency only ratchet release  
Terminal/wire positioning aids & Ins. adjustment on most tools  
Approximate weight 0.95 kg (2.1 lbs)



Part Number	Description	mm <sup>2</sup> (AWG) or other
234170-1	AMP DYNAMIC D-5	1.5 - 2.5 (16-14)
234171-1	AMP DYNAMIC D-5	4.0 - 6.0 (12-10)
1366044-1	AMP DYNAMIC D-5 Receptacle	8.0 (10)
90246-1	PIDG FASTON - Standard tool	2.5 - 4.0 (14-12)
90276-2	PIDG FASTON Qualified; LUL RSE 024 pt6 & EE6161	4.0 - 6.0 (12-10) 1.5 - 2.5 (16-14) HD
484364-1	PIDG STRATO-THERM Terminals & Splices	1.0 (18)
576782	Special GB Aerospace tool for PIDG STRATO-THERM Terminals with PTFE or PEEK for thin-wall Insulation Qualified to BS 4G178	2.5 (14)
576783	Special GB Aerospace tool for PIDG STRATO-THERM Terminals with PTFE or PEEK for thin-wall Insulation Qualified to BS 4G178	4.0 (12)
576784	Special GB Aerospace tool for PIDG STRATO-THERM Terminals with PTFE or PEEK for thin-wall Insulation Qualified to BS 4G178	6.0 (10)
576778	Special GB Aerospace tool for PIDG STRATO-THERM Terminals with PTFE or PEEK for thin-wall Insulation Qualified to BS 4G178	0.2 - 0.4 (24-22)
576779	Special GB Aerospace tool for PIDG STRATO-THERM Terminals with PTFE or PEEK for thin-wall Insulation Qualified to BS 4G178	0.6 (20)
576780	Special GB Aerospace tool for PIDG STRATO-THERM Terminals with PTFE or PEEK for thin-wall Insulation Qualified to BS 4G178	1.0 (18)
576781	Special GB Aerospace tool for PIDG STRATO-THERM Terminals with PTFE or PEEK for thin-wall Insulation Qualified to BS 4G178	1.5 (16)
59239-4	PIDG, PLASTI-GRIP Terminals & Splices - Standard tool for GB Railways Qualified; Mil-T-7928; LUL RSE 024 pt6 & EE6161 Marks the applied product with a one dot indent code.	3.0 - 5.0 (12-10) 1.5 - 2.5 (16-14) HD
59287-2	PIDG, PLASTI-GRIP Large Expansion Terminals & Splices	4.0 - 6.0 (12-10) (16-14) HD
525692	Special GB Aerospace PIDG & PLASTI-GRIP Ring Tongue Tool. Equivalent to 59239-4 but has special retaining pins/rings to reduce the risk of tool parts falling off whilst building and maintaining aircraft.	4.0 - 6.0 (12-10)
69355	SOLISTRAND Terminals & Splices	10.0 (8)
59461	STRATO-THERM Uninsulated Terminals & Splices with Insulation Support	4.0 - 6.0 (12-10) (16-14) HD
90382-2	TYPE XII Contact	1.5 - 4.0 (16-12)
90384-1	TYPE XII Contact	6.0 - 10.0 (10-8)

*Only the most popular options are listed here, please use our online search by terminal PN to find the right tool for your application, and contact us where information is unclear or missing - there may well be something available for your requirement.*

## Heavy Head Hand Tool Battery Tool Kit

Convert your existing Hand Tools into Powered!

1901235-2 - Kit only without head

1901235-5 - Kit only without head (GB Power Plug)

*Image representative of type only*

### Features:

Heads can be removed from many Heavy Head Hand Tools, example:  
the Handles from 59239-4 can be removed and the head used with this kit.  
See Instruction sheet 409-10068 for a list of compatible tools

Over 100 crimps per charge

Compact - only 360mm (14") long and weighs 1.57kg (3.48lbs)

The Tool Kit is supplied in a durable plastic carry case and includes:

Battery Tool with Heavy Head Adapter

Battery Charger 230 v

Two Batteries

for more information, please see the Power Assist section

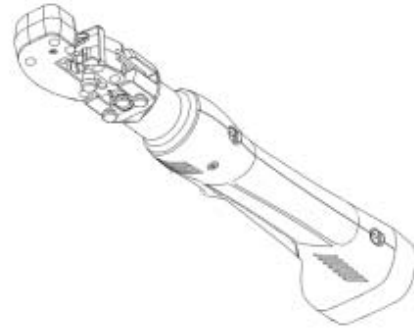

## Adapter - Heavy Head to 626 Pneumatic

525432-1 - Adapter only

### Features:

Heads can be removed from Hand Tools, example:  
the Handles from 59239-4 can be removed and the head used with this Adapter on the 626 Pneumatic system.

Also required:

Adapter Holder with Ratchet 356304-1

or Adapter Holder without Ratchet 189928-1

and

Hand held power unit 189721-1

or Foot actuated Power Unit 189722-1

*Image representative of type only*

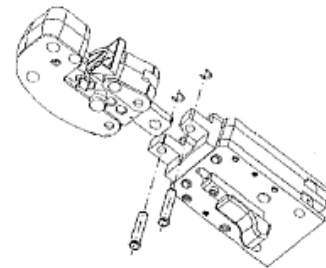

## Reel-Fed CERTI-LOK

A unique tool that applies terminals from special small reels

### Features:

- Terminal feeding and cutting device
- Straight action jaw closure
- Ratchet mechanism ensures complete crimp cycle
- Easy access ratchet release
- Handle pressure adjustment with locking device
- Ergonomic non-slip handles

*Image representative of type only*



Part Number	Description	mm <sup>2</sup> (AWG) or other
734643-1	AMPLIVAR	
734203-1	AMPMODU IV	0.12 - 0.14 (26)
734204-1	AMPMODU IV	0.2 - 0.56 (24-20)
734870-2	MICRO MATCH COSI contact	0.08 - 0.2 (28-24)
734870-1	MICRO MATCH COSI contact	0.2 - 0.6 (24-20)
539608-1	MODU II	0.02 - 0.20 (32-24)
734216-1	TYPE III+	0.2 - 1.5 (24-16)

*Only the most popular options are listed here, please use our online search by terminal PN to find the right tool for your application, and contact us where information is unclear or missing - there may well be something available for your requirement.*

## CERTI-LOK

169400 - Base Tool without Die-set

### Features:

- Interchangeable Dies
- Straight action jaw closure
- Ratchet mechanism ensures complete crimp cycle
- Easy access ratchet release
- Handle pressure adjustment with locking device
- Ergonomic non-slip handles
- Approximate weight 0.64 kg (1.4 lbs)

*Image representative of type only*



## Adapter - CERTI-LOK to Electric Terminator

169411 - Adapter only

### Features:

Adapts the Electric Terminator 539630-1 to take CERTI-LOK Dies

for more information on the Press and Press options, please see the Power Assist section

*Image representative of type only*



## PEZ 100

539717-1 - Base Tool without Die-set  
 1579000-1 - Base Tool without Die-set Long Handles

*Image representative of type only*

### Features:

- Interchangeable Dies
- Flap type terminal locator
- Straight action jaw closure
- Ratchet mechanism ensures complete crimp cycle
- Easy access ratchet release
- Handle pressure adjustment with locking device
- Ergonomic non-slip handles



## ERGOCRIMP

539635-1 - Base tool without Die-set  
 Note: This tool is not compatible with SDE Dies

*Image representative of type only*

### Features:

- Interchangeable Dies
- Virtually a straight action jaw closure
- Ratchet mechanism ensures complete crimp cycle
- Easy access ratchet release
- Handle pressure adjustment with locking device
- Ergonomic non-slip handles
- Approximate weight 0.59 kg (1.3 lbs)

Spare parts Kit 539635-2 (excluding main spring)  
 Main Spring PN 1579005-1



## Tetra-Crimp Hand Tool

58078-3 - Base Tool without Die-set

*Image representative of type only*

### Features:

- Interchangeable Dies
- Ratchet mechanism ensures complete crimp cycle
- Tamper proof ratchet release setting
- Emergency ratchet release feature
- Terminal locator / support and wire stop on many tools
- Approximate weight 0.64 kg (1.4 lbs)
- Ergonomic non-slip handles



Part Number	Description	mm <sup>2</sup> (AWG) or other
58052-3	Die-set for ULTRA FAST	0.15 - 0.4 (26-22)
90390-3	Die-set for ULTRA FAST (including Flag Terminals)	0.4 - 1.0 (22-18)
90391-3	Die-set for ULTRA FAST (including Flag Terminals)	1.5 - 2.5 (16-14)
58079-3	Die-set for ULTRA FAST PLUS	0.4 - 1.0 (22-18)
58080-3	Die-set for ULTRA FAST PLUS	1.5 - 2.5 (16-14)

*Only the most popular options are listed here, please use our online search by terminal PN to find the right tool for your application, and contact us where information is unclear or missing - there may well be something available for your requirement.*

## Mini CERTI-LOK

A light weight and compact tool for many commercial applications

*Image representative of type only*

### Features:

- Fixed dies
- Straight action jaw closure
- Ratchet mechanism ensures complete crimp cycle
- Easy access ratchet release
- Handle pressure adjustment with locking device
- Easy terminal positioning with 'Flap Locator' (some tools)
- Ergonomic non-slip handles
- Approximate weight 0.46 kg (1.0 lbs)



## Modular Mini CERTI-LOK

Based on the Mini Certi-Lok tool

*Image representative of type only*

### Features:

Heads with identical features to the Mini Certilok tool

Choice of two handle lengths:

2-1579005-1 Short Handle

2-1579005-2 long Handle

Interchangerability via snap-in pins.



## C-Frame Hand Tool

6-1419172-9 - Base Tool without Die-set

*Image representative of type only*

### Features:

- Interchangeable Dies
- Double action jaw closure
- Ratchet mechanism ensures complete crimp cycle
- Easy access ratchet release
- Handle pressure adjustment with locking device
- Ergonomic non-slip handles
- Approximate weight 0.55 kg (1.2 lbs)



Part Number	Description	mm <sup>2</sup> (AWG) or other
1583684-1	Die-set for ADK Series Back Shell	6.0 mm Cable Dia Max
1583684-2	Die-set for ADK Series Back Shell	7.5 mm Cable Dia Max
1583684-3	Die-set for ADK Series Back Shell	8.5 mm Cable Dia Max
1583684-4	Die-set for ADK Series Back Shell	9.5 mm Cable Dia Max
948761-1	Complete tool for HDE20 Ferrule	Cable Ø4.8 - 6.3
948761-2	Complete tool for HDE 20 Ferrule	Cable Ø6.3 - 8.2
948761-3	Complete tool for HDE20 Ferrule	cabl e Ø8.2 - 11.1
734566-1	Complete tool for N Series 50 & 70 ohm	

*Only the most popular options are listed here, please use our online search by terminal PN to find the right tool for your application, and contact us where information is unclear or missing - there may well be something available for your requirement.*

## D-Frame Tool

*Image representative of type only*

### Features:

- Fixed Die-sets
- Small and lightweight
- Ratchet mechanism ensures complete crimp cycle
- Easy access ratchet release
- Handle pressure adjustment with locking device
- Ergonomic non-slip handles
- Approximate weight 0.55 kg (1.2 lbs)



Part Number	Description	mm <sup>2</sup> (AWG) or other
947488-1	Coax - BNC, TNC	Cable Dia 5 & 6mm
947679-1	HE 13 / 14 Crimp-on Snap-in	0.08 - 0.2 (28-24)
2-1579002-0	Wire Wire End Ferrules (Square crimp form)	0.5 - 6.0 (22-10)

*Only the most popular options are listed here, please use our online search by terminal PN to find the right tool for your application, and contact us where information is unclear or missing - there may well be something available for your requirement.*

## Trapezium Crimp Tool

Special Trapezium crimp tool for Wire End Ferrule applications

*Image representative of type only*

### Features:

- Ratchet mechanism ensures complete crimp cycle
- Easy access ratchet release
- Handle pressure adjustment with locking device
- Ergonomic non-slip handles



Part Number	Description	mm <sup>2</sup> (AWG) or other
734641-2	Wire End Ferrules (trapezium crimp form)	0.14 - 6.0 (26-10)
734641-3	Wire End Ferrules (trapezium crimp form)	0.5 - 10 (22-6)
734641-4	Wire End Ferrules (trapezium crimp form)	10.0 - 16.0 (8-6)

*Only the most popular options are listed here, please use our online search by terminal PN to find the right tool for your application, and contact us where information is unclear or missing - there may well be something available for your requirement.*

## Square Crimp Tool

Special Square crimp tool for Wire End Ferrule applications

*Image representative of type only*

### Features:

- Ratchet mechanism ensures complete crimp cycle
- Easy access ratchet release
- Handle pressure adjustment with locking device
- Ergonomic non-slip handles



Part Number	Description	mm <sup>2</sup> (AWG) or other
539660-1	Wire Wire End Ferrules (square crimp form)	0.08 - 6.0 (28-10)
539661-1	Wire Wire End Ferrules (square crimp form)	0.75 - 10 (20-8)
7-1579014-0	Wire End Ferrules DIN 46228 Pt. 1 & 4 - crimp length 13mm. Crimp is indented on two sides only - (better for smaller sizes)	0.08 - 10.0 (28-8)

*Only the most popular options are listed here, please use our online search by terminal PN to find the right tool for your application, and contact us where information is unclear or missing - there may well be something available for your requirement.*

## Service Tool

734790-1 - Base Tool without Die-set

*Image representative of type only*

### Features:

- Interchangeable Dies
- Ratchet mechanism ensures complete crimp cycle
- Easy access ratchet release
- Handle pressure adjustment with locking device
- Ergonomic non-slip handles
- Approximate weight 0.59 kg (1.3 lbs)



## TERMI-POINT Hand Tool

### Features:

Pneumatic options (pictured)  
Interchangeable Mandrels  
Terminals fed from Reel

*Image representative of type only*



Part Number	Description	mm <sup>2</sup> (AWG) or other
655032-1	Hand Tool without Mandrel for Maxi TERMI-POINT	0.2 - 0.56 (24-20)
69526-2	Hand Tool without Mandrel	0.08 - 0.4 (28-22)
69551-5	Mandrel (black) for 69526-2	0.08 (28) Ins. Ø1.14-1.65mm
69551-6	Mandrel (brown) for 69526-2	0.15 (26) Ins. Ø0.56-1.14 mm
871295-5	Mandrel (brown) for 871087-2	0.15 (26) Ins. Ø0.76-1.40mm
1-69411-9	Mandrel (brown) for 69526-2	0.15 (26) Ins. Ø1.14-1.65mm
655136-3	Hand Tool without Mandrel	0.2 - 0.4 (24-22)
69551-9	Mandrel (red) for 69526-2	0.2 (24) Ins. Ø0.74-1.23mm
871295-2	Mandrel (red) for 871087-1	0.2 (24) Ins. Ø0.86-1.65mm
871295-4	Mandrel (red) for 871087-2	0.2 (24) Ins. Ø0.86-1.65mm
69561-4	Mandrel (red) for 654182-1	0.2 (24) Ins. Ø1.1 -1.65mm
1-69411-3	Mandrel (red) for 69526-2	0.2 (24) Ins. Ø1.10-1.65mm
871087-2	Hand Tool (pneumatic) without Mandrel	0.4 - 0.15 (22-26)
69551-8	Mandrel (orange) for 69526-2	0.4 (22) Ins. Ø0.87-1.23mm
871295-3	Mandrel (orange) for 871087-2	0.4 (22) Ins. Ø0.91-1.65mm
1-69411-4	Mandrel (orange) for 69526-2	0.4 (22) Ins. Ø1.14-1.65mm
871295-1	Mandrel (yellow) for 871087-1	0.56 (22) Ins. Ø0.91-1.65mm
69561	Mandrel (yellow) for 654182-1	0.56 (22) Ins. Ø1.17-1.65mm
69561-1	Mandrel (yellow) for 654182-1	0.56 (22) Ins. Ø1.68-2.16mm
654182-1	Hand Tool without Mandrel	0.6 - 0.2 (20-24)
871087-1	Hand Tool (pneumatic) without Mandrel	0.6 - 0.2 (20-24)

*Only the most popular options are listed here, please use our online search by terminal PN to find the right tool for your application, and contact us where information is unclear or missing - there may well be something available for your requirement.*



## Service Kit Tool

Ideal for Service and Repair

### Features:

- Tool-less Die change
- Ratchet mechanism ensures complete crimp cycle
- Emergency ratchet release feature
- Ergonomic non-slip handles
- Approximate weight 0.46 kg (1.0 lbs)

*Image representative of type only*



Part Number	Description	mm <sup>2</sup> (AWG) or other
3-1579000-0	Hand Tool Frame only - Service Kit Tool	

*Only the most popular options are listed here, please use our online search by terminal PN to find the right tool for your application, and contact us where information is unclear or missing - there may well be something available for your requirement.*

## Die-set - Service Kit Tool

Build up your own kit!

### Features:

- Upper & lower Dies are permanently joined
- Interlocking Die-set holders

Use in Service Kit Tool 3-1579000-0

*Image representative of type only*



Part Number	Description	mm <sup>2</sup> (AWG) or other
3-1579016-4	FASTON 6.3 [.250]	0.5 - 6.0 (22-10)
3-1579016-1	PIDG, PLASTIGRIP Terminals & Splices	0.1 - 6.0 (26-10) Green / Yellow
3-1579016-2	PIDG, PLASTIGRIP Terminals & Splices	0.5 - 2.5 (22-14) Red / Blue
3-1579016-3	SOLISTRAND Terminals & Splices	0.5 - 6.0 (22-10)
3-1579016-5	Wire End Ferrules	0.25 - 10.0 (24-8)

*Only the most popular options are listed here, please use our online search by terminal PN to find the right tool for your application, and contact us where information is unclear or missing - there may well be something available for your requirement.*