

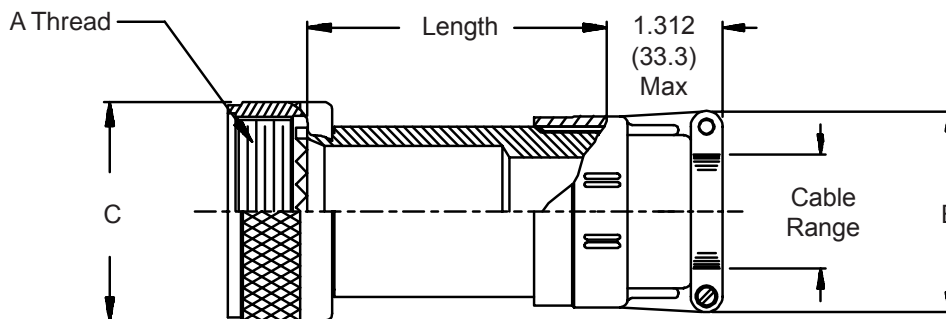

## AS85049/21 Non-Environmental Strain Relief Backshells

**Glenair Connector  
Designator H**

**MIL-DTL-38999  
Series III & IV,  
EN3645**

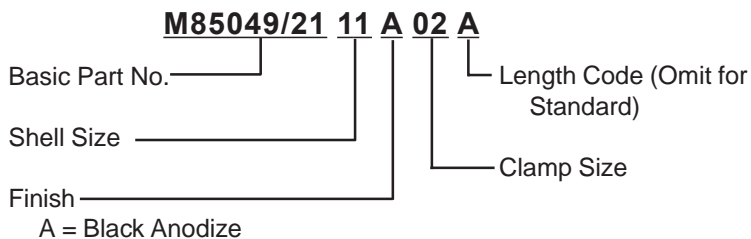

**TABLE I**

Shell Size	Clamp Size (Table IV)		A Thread Class 2B	C Dia Max
	Min	Max		
9	01	02	M12 X 1 - 6H	.75 (19.1)
11	01	03	M15 X 1 - 6H	.85 (21.6)
13	02	04	M18 X 1 - 6H	1.00 (25.4)
15	02	05	M22 X 1 - 6H	1.10 (27.9)
17	02	06	M25 X 1 - 6H	1.25 (31.8)
19	03	07	M28 X 1 - 6H	1.40 (35.6)
21	03	08	M31 X 1 - 6H	1.50 (38.1)
23	03	09	M34 X 1 - 6H	1.65 (41.9)
25	04	10	M37 X 1 - 6H	1.75 (44.5)

**TABLE II**

Clamp Size	Cable Range		E Max
	Min	Max	
01	.062 (1.6)	.125 (3.2)	.80 (20.3)
02	.125 (3.2)	.250 (6.4)	1.00 (25.4)
03	.250 (6.4)	.375 (9.5)	1.10 (27.9)
04	.312 (7.9)	.500 (12.7)	1.20 (30.5)
05	.437 (11.1)	.625 (15.9)	1.25 (31.8)
06	.562 (14.3)	.750 (19.1)	1.40 (35.6)
07	.687 (17.4)	.875 (22.2)	1.50 (38.1)
08	.812 (20.6)	1.000 (25.4)	1.65 (41.9)
09	.937 (23.8)	1.125 (28.6)	1.75 (44.5)
10	1.062 (27.0)	1.250 (31.8)	1.90 (48.3)

**TABLE III**

Length Code	Available Shell Sizes	Length
Std.	09 - 25	1.500 (38.1)
A	09 - 25	2.500 (63.5)
B	15 - 25	3.500 (88.9)
C	21 - 25	4.500 (114.3)

1. For complete dimensions see applicable Military Specification.
2. Metric dimensions (mm) are indicated in parentheses.
3. Cable range is defined as the accommodation range for the wire bundle or cable. Dimensions shown are not intended for inspection criteria.