

Features

- Multiturn / Cermet / Industrial / Sealed
- Low temperature coefficient: ± 100 ppm/°C
- Stable, infinite resolution cermet element
- CRV 1.0 % or 1 ohm
- Panel mount option available
- RoHS compliant* version available

3009 - 3/4 " Rectangular Trimpot® Trimming Potentiometer

Electrical Characteristics

Standard Resistance Range
..... 10 to 2 megohms
(see standard resistance table)

Resistance Tolerance ± 10 % std.
(tighter tolerance available)

Absolute Minimum Resistance
..... 1.0 % or 2 ohms max.
(whichever is greater)

Contact Resistance Variation
..... 1.0 % or 1 ohm max.
(whichever is greater)

Adjustability
Voltage..... ± 0.01 %
Resistance..... ± 0.05 %
Resolution..... Infinite

Insulation Resistance 500 vdc
100 megohms min.

Dielectric Strength
Sea Level..... 1,000 vac
80,000 Feet 250 vac
Adjustment Angle 15 turns nom.

Environmental Characteristics

Power Rating (400 volts max.)
70 °C..... 0.75 watt
150 °C 0 watt

Temperature Range..... -55 °C to +125 °C

Temperature Coefficient
..... ± 100 ppm/°C

Seal Test..... 85 °C Fluorinert†

Humidity..... MIL-STD-202 Method 103
96 hours
(3 % Δ TR, 20 megohms IR)

Vibration..... 20 G (2 % Δ TR; 2 % Δ VR)

Shock..... 50 G (2 % Δ TR; 2 % Δ VR)

Load Life
..... 1,000 hours, 0.75 watt @ 70 °C
(4 % Δ TR)

Rotational Life..... 200 cycles
(3 % Δ TR; 1 % or 1 ohm,
whichever is greater, CRV)

Physical Characteristics

Torque 5.0 oz-in. max.

Mechanical Stops..... Wiper idles

Terminals..... Solderable pins

Weight 0.05 oz.

Marking Manufacturer's
trademark, resistance code,
terminal numbers, date code,
manufacturer's model number
and style

Standard Packaging..... 25 pcs. per tube

REV. 08/10

*RoHS Directive 2002/95/EC Jan 27 2003 including Annex.
"Trimpot" is a registered trademark of Bourns, Inc.
†"Fluorinert" is a registered trademark of 3M Co.
Specifications are subject to change without notice.
Customers should verify actual device performance in their specific applications.

Product Dimensions

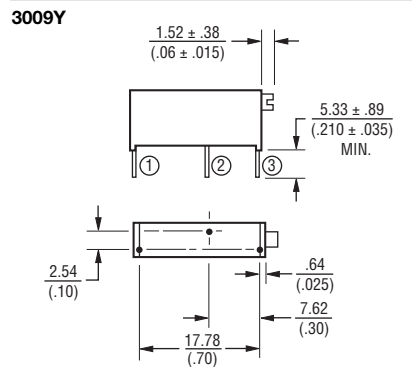
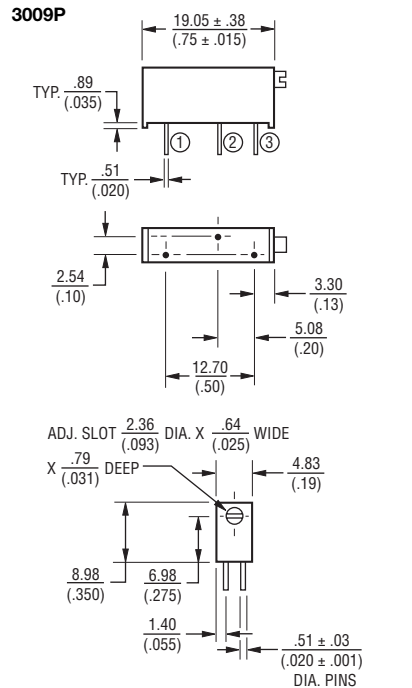

DIMENSIONS: $\frac{\text{MM}}{\text{(INCHES)}}$

TOLERANCES: $\frac{0.25}{(.010)}$ EXCEPT WHERE NOTED



Standard Resistance Table

Resistance (Ohms)	Resistance Code
10	100
20	200
50	500
100	101
200	201
500	501
1,000	102
2,000	202
5,000	502
10,000	103
20,000	203
25,000	253
50,000	503
100,000	104
200,000	204
250,000	254
500,000	504
1,000,000	105
2,000,000	205

How To Order

3009 P - 1 - 103 Z LF

Model _____

Style _____

Standard or Modified _____

Product Indicator _____
-1 = Standard Product
-11 = 5 % Resistance Tolerance

Resistance Code _____

Optional Suffix Letter _____
Z = Panel Mount (Factory Installed)

Terminations _____
LF = 100 % Tin-plated (RoHS compliant)
Blank = 90 % Tin / 10 % Lead-plated (Standard)

Consult factory for other available options.