

AME50461 SERIES

EMI FILTER HYBRID-HIGH RELIABILITY

Description

The AME Series of EMI filters have been designed to provide full compliance with the input line reflected ripple current requirement specified by CE03 of MIL-STD-461C over the full military temperature range while operating in conjunction with the corresponding AFL series of DC-DC converters. These filters are offered as part of a complete family of conversion products providing single and dual output voltages while operating from nominal +28, +50 or +270 input line voltage. Other converters operating with a similar switching frequency will also benefit by use of this device.

These EMI filters are hermetically packaged in two enclosure variations, utilizing copper-core pins to minimize resistive DC losses. Three lead styles are available, each fabricated with International Rectifiers's rugged ceramic lead-to-package seal assuring long term hermetic seal integrity in harsh environments.

Manufactured in a facility fully qualified to MIL-PRF-38534, these converters are available in four screening grades to satisfy a wide range of applications. The CH grade is fully compliant to the requirements of MIL-PRF-38534 for class H. The HB grade is fully processed and screened to the class H requirement, but does not include element evaluation to the class H requirement.

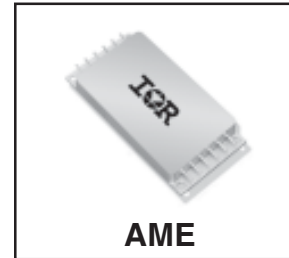

Features

- Up to 7.0 Ampere Output Current
- Attenuation > 35dB @ 200 KHz
- Low Profile (0.38") Seam Welded Package
- Ceramic Feedthru Copper-Core Pins
- Operation Over Full Military Temp. Range
- Standard Military Drawings Available

Both grades are tested to meet the complete group "A" test specification over the full military temperature range with no derating. Two grades with more limited screening are also available for use in less demanding applications. Variations in electrical, mechanical and screen requirements can be accommodated. Contact IR San Jose for special requirements.

Typical Connection Diagram

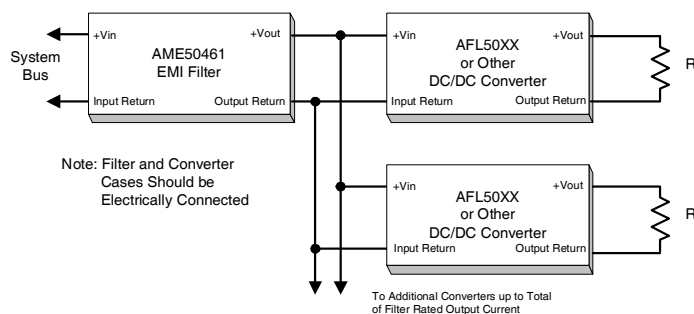

Specifications

ABSOLUTE MAXIMUM RATINGS Note 1	
Input Voltage	-300V to +300V Note 2
Input Current	7.0A
Lead Soldering Temperature	300°C for 10 seconds
Case Temperature	Operating -55°C to +125°C Storage -65°C to +135°C

Electrical Characteristics $-55^{\circ}\text{C} \leq T_{\text{CASE}} \leq +125^{\circ}\text{C}$, $-100\text{V} \leq V_{\text{IN}} \leq +100\text{V}$ unless otherwise specified

Parameter	Group A Subgroups	Test Conditions	Min	Max	Unit
Leakage Current Note 3	1, 2, 3	$\pm 250\text{V}$ DC Input Voltage	0	50	μA
DC Resistance Note 4	1, 2, 3	$T_{\text{C}} = 25^{\circ}\text{C}$ $T_{\text{C}} = 125^{\circ}\text{C}$		60 100	$\text{m}\Omega$
Noise Reduction	4, 5, 6	200 KHz - 500 KHz 500 KHz - 1 MHz 1 MHz - 10 MHz	35 60 65		dB
Isolation	1	Any Pin to Case, Tested @ 500VDC	100		$\text{M}\Omega$
Capacitance	1 2, 3	Measured Between Any Pin and Case	34 30	56 62	nF

Notes to Specifications

1. Operation above maximum ratings may cause permanent damage to the device. Operation at maximum ratings may degrade performance and affect reliability.
2. Device can tolerate ± 300 Volt transient whose duration is ≤ 100 ms when $R_{\text{S}} \geq 0.5 \Omega$.
3. Derate Output Current linearly from 100% at 125°C to 0 at 135°C .
4. DC resistance is the total resistance of the device and includes the sum of the *input to output* resistance and the *return in to return out* resistance paths.

Block Diagram

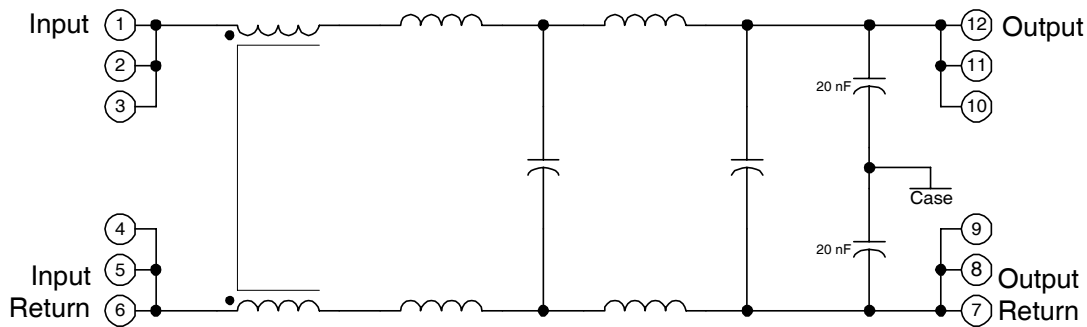

Refer to last page for Pin Designation

Circuit Operation and Application Information

The AME series of filters employ three stages of filtering in a low pass configuration designed to attenuate the higher frequency components of ripple currents generated by high frequency switching DC-DC converters. The Block Diagram describes the general arrangement of the principal elements which have been connected to provide both differential and normal mode buffering between the input and output terminals.

Employing only passive elements, AME filter operation is initiated simply by insertion into the input power path between one or more DC-DC converters and their input DC voltage bus. In this connection, output pins of the filter will be connected to input pins of the converters.

When a single AME filter is used in conjunction with multiple DC-DC converters, the use will be limited to the maximum output current capability specified in the AME electrical table.¹ A typical connection utilizing one filter to drive two converters is illustrated on page1.

Although expressly designed to complement the AFL series of DC-DC converters, the AME50461 filters can be successfully operated in conjunction with other converters in the Advanced Analog line including the ASA, AHF, AHV and ATR series.

¹ To calculate the input current (i_{in}) requirement of any one converter, first determine the maximum output power by multiplying output voltage by maximum load current, divide this power by the efficiency to obtain input power and then divide input power by input voltage to obtain the input current (i_{in}). Note that to obtain worst case input current, you must use maximum load current, minimum efficiency and minimum line voltage in this calculation.

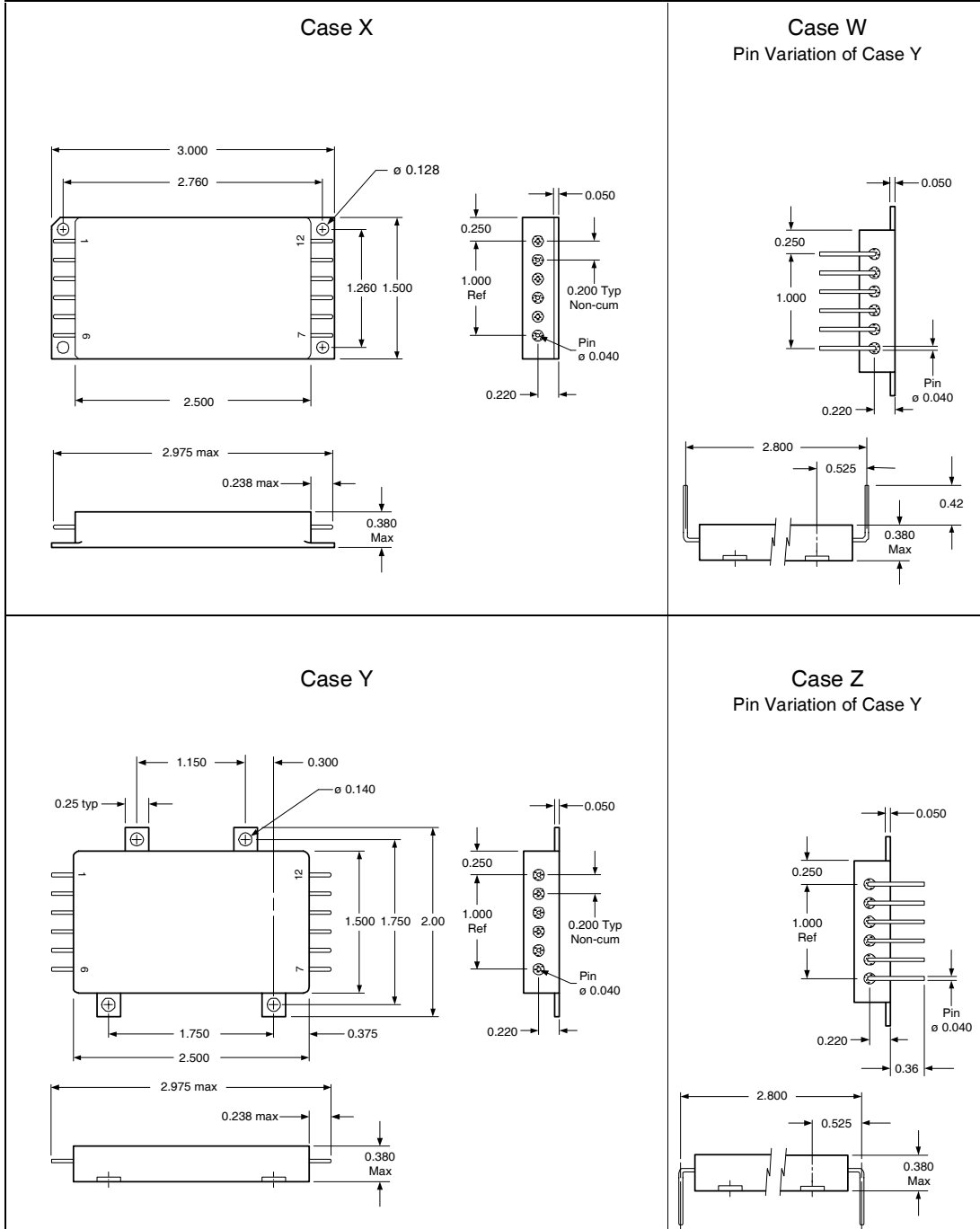

Tolerances, unless otherwise specified: .XX = ±0.010
.XXX = ±0.005

Available Screening Levels and Process Variations

Requirement	MIL-STD-883 Method	No Suffix	ES Suffix	HB Suffix	CH Suffix
Temperature Range		-20 to +85°C	-55°C to +125°C	-55°C to +125°C	-55°C to +125°C
Element Evaluation					MIL-PRF-38534
Internal Visual	2017	*	Yes	Yes	Yes
Temperature Cycle	1010		Cond B	Cond C	Cond C
Constant Acceleration	2001		500g	Cond A	Cond A
Burn-in	1015	48hrs @ 85°C	48hrs @ 125°C	160hrs @ 125°C	160hrs @ 125°C
Final Electrical (Group A)	MIL-PRF-38534 & Specification	25°C	25°C	-55, +25, +125°C	-55, +25, +125°C
Seal, Fine & Gross	1014	Cond A	Cond A, C	Cond A, C	Cond A, C
External Visual	2009	*	Yes	Yes	Yes

* Per Commercial Standards

Pin Designation

Pin No.	Designation
1	Positive Input
2	Positive Input
3	Positive Input
4	Input Return
5	Input Return
6	Input Return
7	Output Return
8	Output Return
9	Output Return
10	Positive Output
11	Positive Output
12	Positive Output

Part Numbering

