

MODEL LC SERIES

Low Pass Filter

Leadless Surface Mount Chip Inductor/Capacitors

NEW PRODUCT



LOW PASS FILTER TECHNOLOGY

LC and RC filters are offered by BI to solve issues of unwanted noise. Each has cost/performance trade offs.

LC composite construction has superior performance through the entire frequency range and has the sharpest roll off compared with RCs.

Thick film RC is the lowest cost and provides good performance.

Thin film RC offers good performance (under 1GHz), moderate cost and very good multi-element density.

APPLICATIONS

- EMI/RFI filtering
- On-board controllers and ethernet
- Digital communications: facsimile machines, modems and ISDN
- Digital AV equipment: television, video camrecorders and DVD
- LAN, WAN, universal serial bus cards and graphics card
- Computers and peripherals

FEATURES AND BENEFITS

- Integrated ladder filter
- Small outline 0805 and 1206 sizes
- Low profile suitable for PCMCIA cards
- Nickel barrier terminations
- Monolithic construction
- Steep insertion loss
- Eliminates noise over a wide frequency range
- Requires no chip orientation
- Ideal for high frequency, space limited designs

Specifications subject to change without notice.

4

TYPICAL PERFORMANCE - MODEL LC 0805

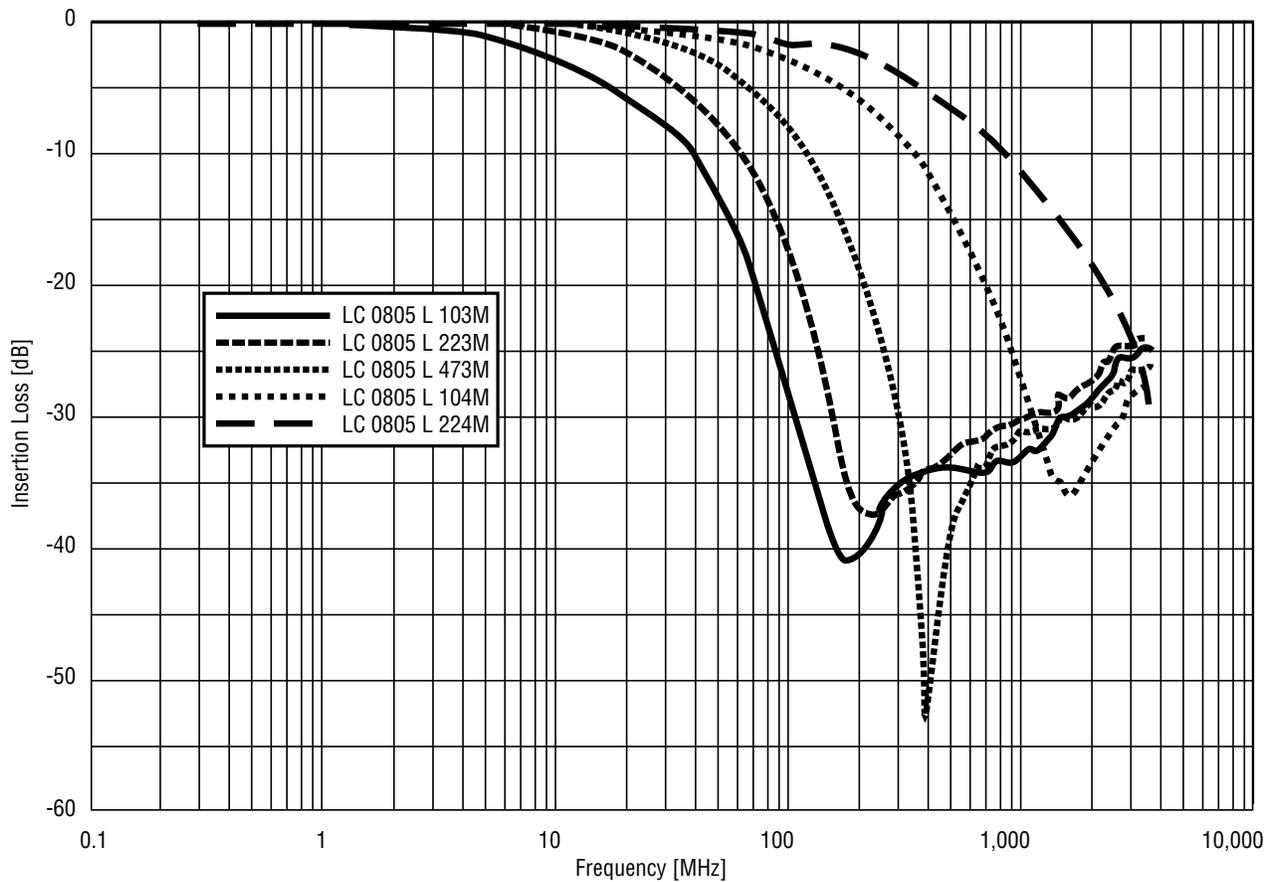

| Cutoff Frequency (Code) | 103 | 223 | 473 | 104 | 224 |
|-----------------------------|------------------------|-------|-------|-------|-------|
| Temperature Characteristics | -25°C to +85°C | | | | |
| (Tolerance) | +30%, -20% | | | | |
| Inductance at 1MHz | Meets cutoff frequency | | | | |
| (Reference) | 200nH | 180nH | 200nH | 110nH | 70nH |
| Magnetic Loss at 1MHz | ≤3.0 | | | | |
| (Reference) | 2.5 | 1.8 | 1.4 | 2.2 | 2.7 |
| Capacitance at 1MHz | Meets cutoff frequency | | | | |
| (Reference) | 600pF | 300pF | 100pF | 30pF | 15pF |
| Dissipation Factor at 1MHz | ≤5.0% | | | | |
| (Reference) | 2.4% | 1.8% | 1.9% | 1.9% | 2.3% |
| DC Resistance | ≤6.0 Ω | | | | |
| (Reference) | 3.0 Ω | 1.8 Ω | 1.8 Ω | 1.5 Ω | 1.2 Ω |

TYPICAL PERFORMANCE - MODEL LC 1206

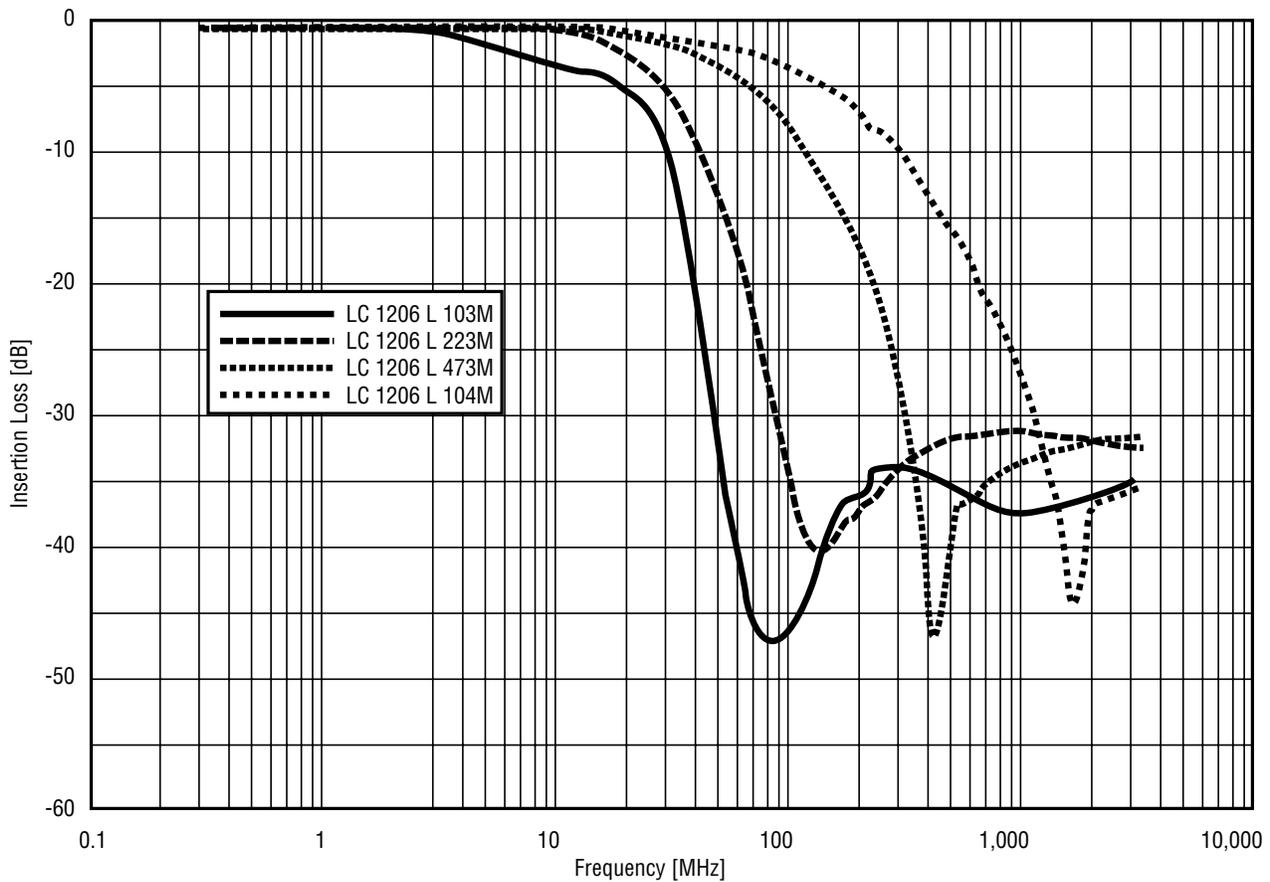

| Cutoff Frequency (Code) | 103 | 223 | 473 | 104 |
|-----------------------------|------------------------|-------|-------|-------|
| Temperature Characteristics | -25°C to +85°C | | | |
| (Tolerance) | +30%, -20% | | | |
| Inductance at 1MHz | Meets cutoff frequency | | | |
| (Reference) | 330nH | 550nH | 220nH | 150nH |
| Magnetic Loss at 1MHz | ≤3.0 | | | |
| (Reference) | 1.1 | 0.6 | 1.0 | 1.5 |
| Capacitance at 1MHz | Meets cutoff frequency | | | |
| (Reference) | 760pF | 200pF | 100pF | 20pF |
| Dissipation Factor at 1MHz | ≤5.0% | | | |
| (Reference) | 3.0% | 1.7% | 2.0% | 2.3% |
| DC Resistance | ≤6.0 Ω | | | |
| (Reference) | 2.6 Ω | 1.9 Ω | 1.4 Ω | 1.4 Ω |

ELECTRICAL

| Part Number | Cutoff Frequency -3dB ($\pm 20\%$) | Rated Voltage | Rated Current Max. | DCR Max. |
|------------------|--------------------------------------|---------------|--------------------|--------------|
| LC 0805 L 103M | 10 MHz | 25Vdc | 100mA dc | 6 Ohms |
| LC 1206 L 103M | 10 MHz | 25Vdc | 100mA dc | 6 Ohms |
| LC 0805 L 223M | 22 MHz | 25Vdc | 100mA dc | 6 Ohms |
| LC 1206 L/H 223M | 22 MHz | 25Vdc | 100mA dc/1A dc | 6 Ohms/1 Ohm |
| LC 0805 L/H 473M | 47 MHz | 25Vdc | 100mA dc/1A dc | 6 Ohms/1 Ohm |
| LC 1206 L/H 473M | 47 MHz | 25Vdc | 100mA dc/1A dc | 6 Ohms/1 Ohm |
| LC 0805 L/H 104M | 100 MHz | 25Vdc | 100mA dc/1A dc | 6 Ohms/1 Ohm |
| LC 1206 L/H 104M | 100 MHz | 25Vdc | 100mA dc/1A dc | 6 Ohms/1 Ohm |
| LC 0805 L/H 224M | 220 MHz | 25Vdc | 100mA dc/1A dc | 6 Ohms/1 Ohm |

FILTER DESIGN COMPARISON AND BENEFITS

Low pass filters are most commonly used in high frequency circuits where the probability of noise is significant.

The LC Series, a ladder type low pass filter, is the most suitable for attenuating unwanted noise.

The LC Series is an integrated passive device with the equivalent of four inductors and three capacitors imbedded into a single 0805 or 1206 monolithic chip.

The LC Series **integrated passive ladder construction**

is superior to discrete solutions at **high frequencies** due to very short internal interconnections.

The LC Series' ladder construction is superior to "T" styles by offering greater attenuation beyond the cutoff frequency.

The LC Series low pass filters offer **steeper** insertion loss and **greater** noise attenuation than other filters.

The LC Series provides signal attenuation below -20dB above 1GHz.

ENVIRONMENTAL

| | |
|---------------------|--|
| Solderability | JIS C5102 8.4, 230°, 4 seconds, 90% coverage |
| Life | 2 x rated voltage, ΔC , ΔL , $\leq 30\%$, 1,000 hours at 85°C |
| Temperature Cycle | JIS C5102 9.3, -25°C to +85°C, 5 cycles, ΔC , ΔL , $\leq 20\%$ |
| Moisture Resistance | +65°C, 90% R.H., 1,000 hours, ΔC , ΔL , $\leq 30\%$ |

OUTLINE DIMENSIONS (Inch/mm)

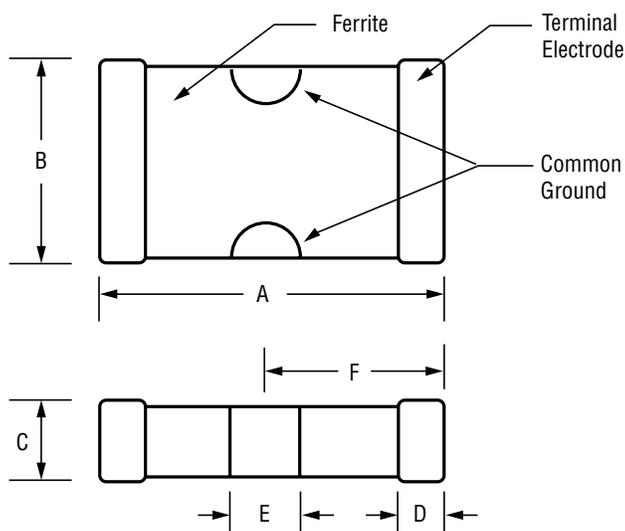

| Size | A Dim. | B Dim. | C Dim. | D Dim. | E Dim. | F Dim. |
|------|-----------|-----------|-----------|-----------|-----------|-----------|
| 0805 | .079±.008 | .049±.008 | .031±.008 | .012±0.10 | .024±0.12 | .039±008 |
| 2012 | 2.0±0.20 | 1.25±0.20 | 0.8±0.20 | 0.3±0.25 | 0.6±0.30 | 1.0±0.20 |
| 1206 | .126±.008 | .063±008 | .039±008 | .016±012 | .043±.012 | .063±.012 |
| 3216 | 3.2±0.20 | 1.6±0.20 | 1.0±0.20 | 0.4±0.30 | 1.1±0.30 | 1.6±0.30 |

RECOMMENDED PCB LAYOUT (Inch/mm)

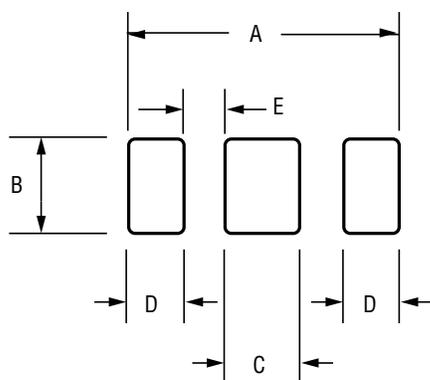

| Model | A Dim. | B Dim. | C Dim. | D Dim. | E Dim. |
|---------|--------|--------|--------|--------|--------|
| LC 0805 | .160 | .080 | .060 | .036 | .014 |
| | 4.0 | 2.0 | 1.5 | .90 | .35 |
| LC 1206 | .110 | .070 | .036 | .025 | .012 |
| | 2.8 | 1.8 | .90 | .65 | .30 |

Note: Via recommended between ground plane and center pad.

SCHEMATIC

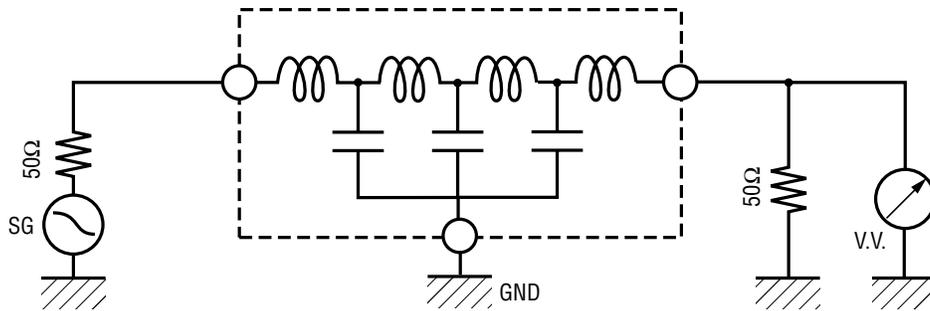

ORDERING INFORMATION

