

2-line IPAD™, EMI filter with ESD protection

Features

- 2-line low-pass filter + ESD protection
- High efficiency in EMI filtering
- Lead-free package
- Very low PCB space occupation <math>< 3.2 \text{ mm}^2</math>
- Very thin package: 0.65 mm
- High efficiency in ESD suppression
- High reliability offered by monolithic integration
- High reduction of parasitic elements through integration and wafer level packaging

Complies with the following standards:

- IEC 61000-4-2
 - 15 kV (air discharge)
 - 8 kV (contact discharge)
- MIL STD 883E - Method 3015-6 Class 3

Application

EMI filtering and ESD protection for USB port.

Description

The EMIF02-USB02F2 is a highly integrated array designed to suppress EMI / RFI noise for a USB port. The EMIF02-USB02F2 Flip Chip packaging means the package size is equal to the die size.

Additionally, this filter includes ESD protection circuitry which prevents damage to the application when subjected to ESD surges up to 15 kV.

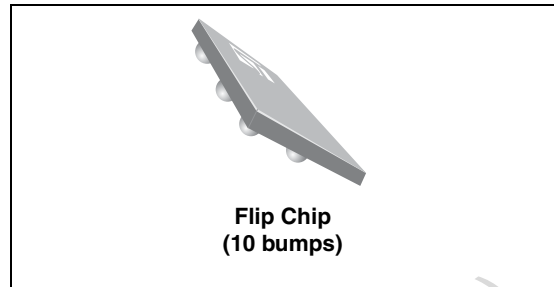

Figure 1. Pin layout (bump side)

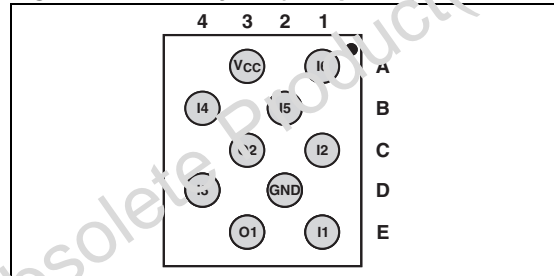
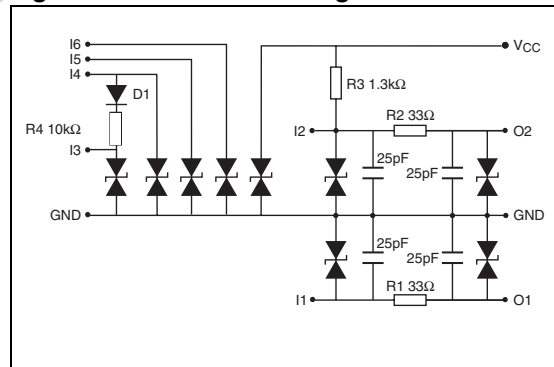

Figure 2. Basic cell configuration



1 Characteristics

Table 1. Absolute ratings ($T_{amb} = 25\text{ }^{\circ}\text{C}$)

Symbol	Parameter and test conditions	Value	Unit
V_{PP}	ESD discharge IEC 61000-4-2, air discharge ESD discharge IEC 61000-4-2, contact discharge	15 8	kV
T_j	Junction temperature	125	$^{\circ}\text{C}$
T_{op}	Operating temperature range	- 40 to + 85	$^{\circ}\text{C}$
T_{stg}	Storage temperature range	- 55 to + 150	$^{\circ}\text{C}$

Table 2. Electrical characteristics ($T_{amb} = 25\text{ }^{\circ}\text{C}$)

Symbol	Parameter								
V_{BR}	Breakdown voltage								
I_{RM}	Leakage current @ V_{RM}								
V_{RM}	Stand-off voltage								
V_{CL}	Clamping voltage								
R_d	Dynamic impedance								
I_{PP}	Peak pulse current								
$R_{I/O}$	Series resistance between input and output								
C_{line}	Input capacitance per line								
Symbol	Test conditions					Min.	Typ.	Max.	Unit
V_{BR}	$I_R = 1\text{ mA}$					6			V
I_{RM}	$V_{RM} = 3\text{ V}$		0.1	0.5	μA				
C_{line}	@ 0V			50	pF				
R_1, R_2	Tolerance $\pm 5\%$		33		Ω				
R_3	Tolerance $\pm 5\%$		1.3		k Ω				
R_4	Tolerance $\pm 5\%$		10		k Ω				
V_F	@ 1 mA (D1 diode)		1		V				

Figure 3. Attenuation measurement

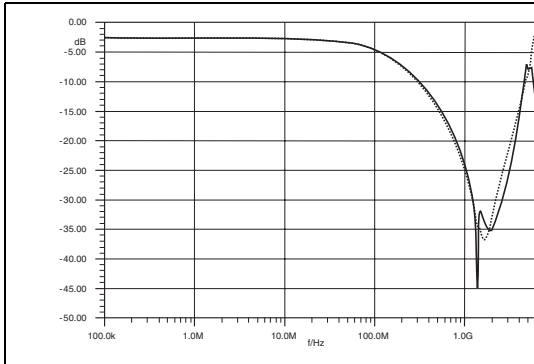

Figure 4. Analog crosstalk measurement (I1- O2)

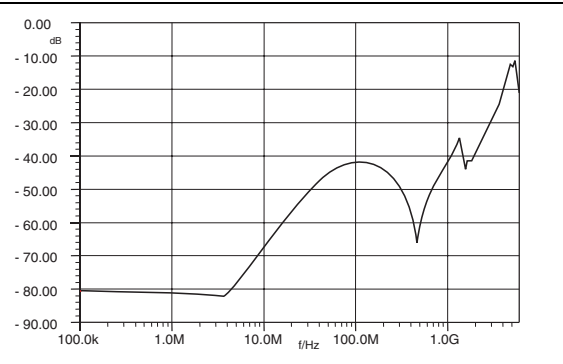

Figure 5. ESD response to IEC 61000-4-2 (+15kV contact discharge)

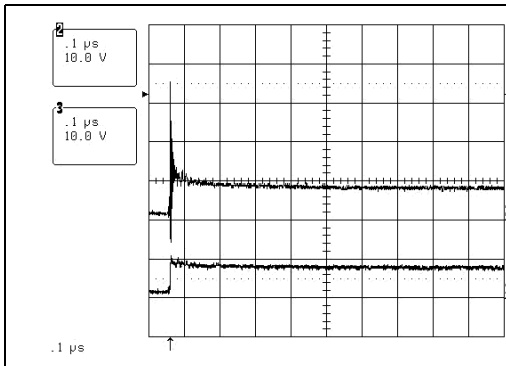
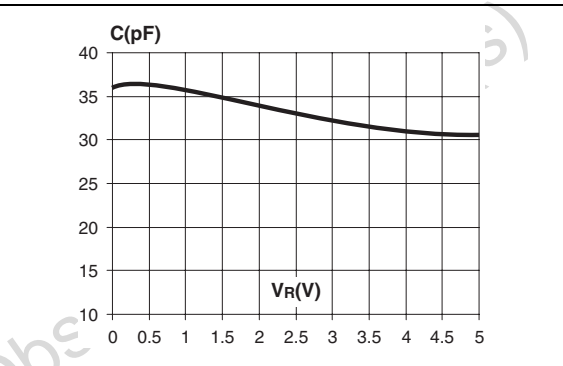

Figure 6. Line capacitance versus reverse applied voltage



Obsolete Product(s) - Obsolete

2 Application information

Figure 7. APlac model of D+ & D- cells

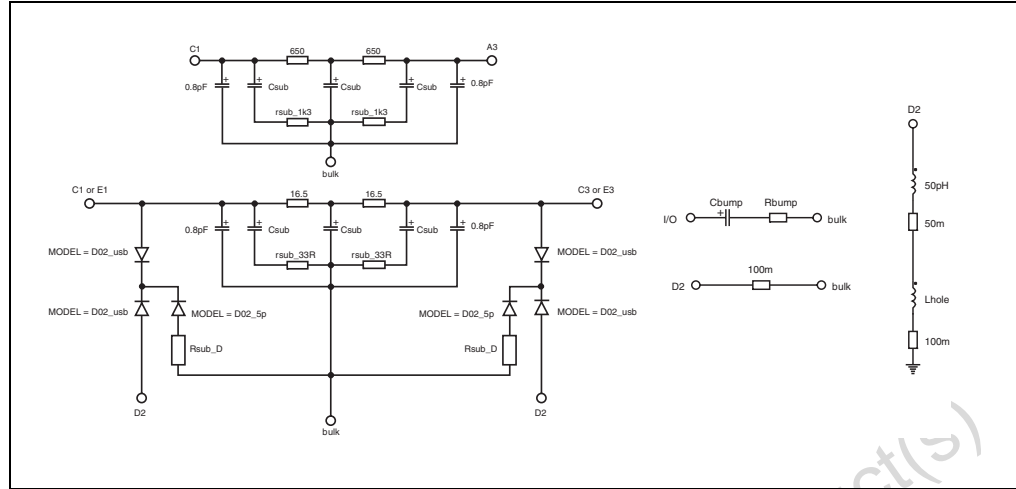
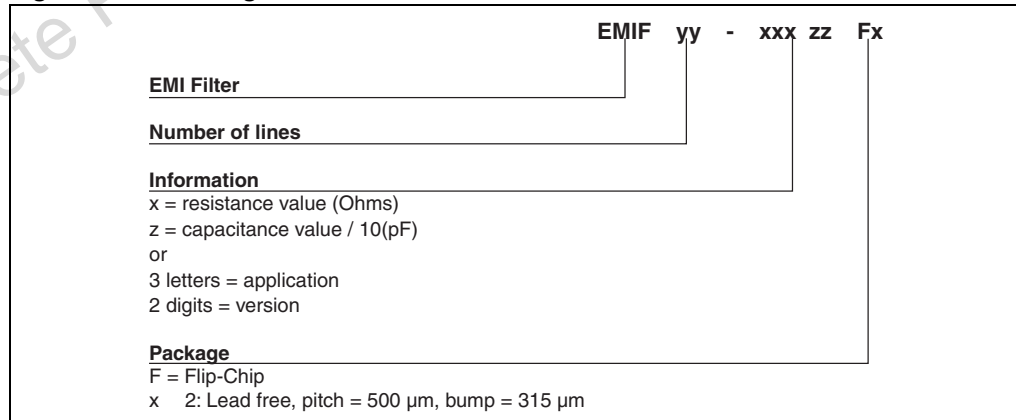

Figure 8. APlac model parameters

Cz 17pF opt	D02_usb diodes model	D02_5p diodes model
Ls 0.4nH	+ BV = 7	+ BV = 100
Rs 0.1	+ IBV = 1m	+ IBV = 1m
Rsub_D 10	+ CJO = Cz	+ CJO = 5p
Csub 0.3pF	+ M = 0.3333	+ M = 0.3333
Rsub_33R 16	+ RS = 2	+ RS = 2
Rsub_1k3 18	+ VJ = 0.6	+ VJ = 0.6
Lhole 170pH opt	+ TT = 100n	+ TT = 100n
Cbump 1.2pF opt		
Rbump 350		

3 Ordering information scheme

Figure 9. Ordering information scheme



4 Package information

In order to meet environmental requirements, ST offers these devices in ECOPACK[®] packages. These packages have a lead-free second level interconnect. The category of second level interconnect is marked on the inner box label, in compliance with JEDEC Standard JESD97. The maximum ratings related to soldering conditions are also marked on the inner box label. ECOPACK is an ST trademark. ECOPACK specifications are available at www.st.com.

Figure 10. Flip Chip package dimensions

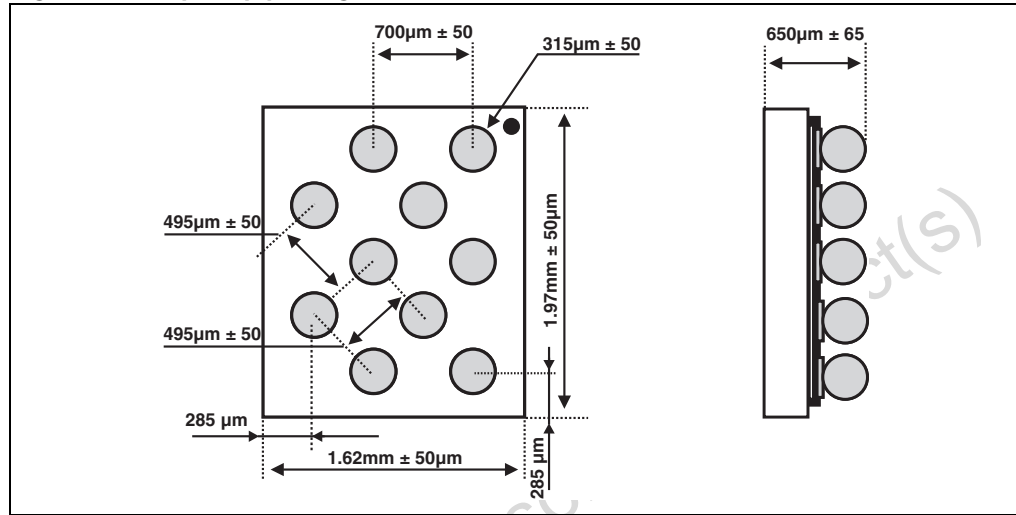

Figure 11. Footprint recommendations Figure 12. Marking

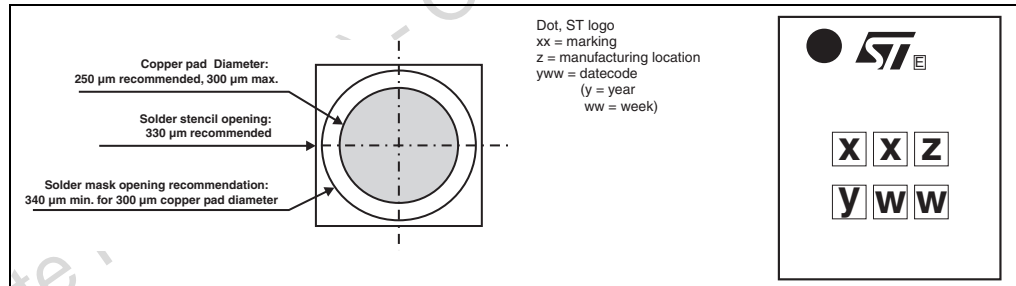
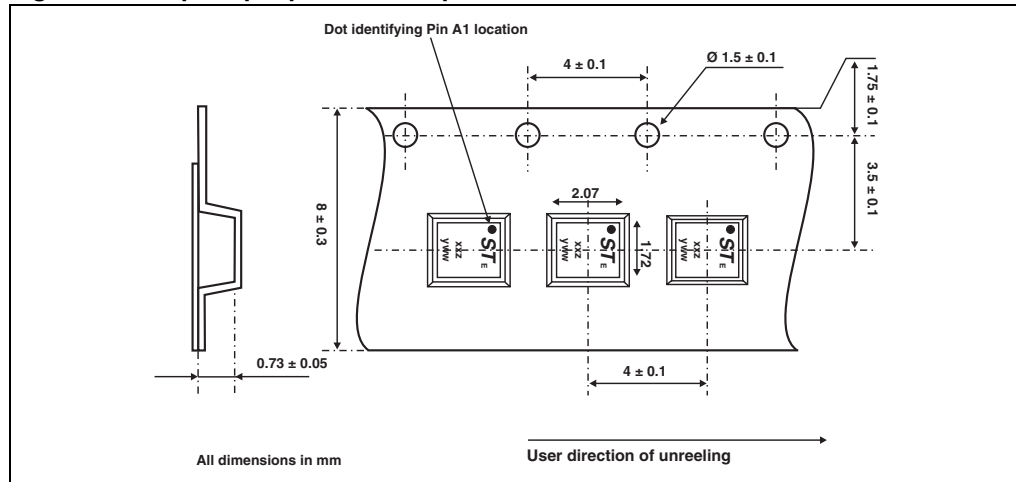

Figure 13. Flip Chip tape and reel specification



Note: More information is available in the application notes:
 AN1235: "Flip Chip: Package description and recommendations for use"
 AN1751: "EMI Filters: Recommendations and measurements"

5 Ordering Information

Table 3. Ordering information

Order code	Marking	Package	Weight	Base qty	Delivery mode
EMIF02-USB02F2	FG	Flip Chip	4.25 mg	5000	Tape and reel 7"

6 Revision history

Table 4. Document revision history

Date	Revision	Changes
14-Dec-2004	1	First issue
28-Apr-2008	2	Updated ECOPACK statement. Updated Figure 9 , Figure 10 , Figure 12 , and Figure 13 . Reformatted to current standards.

Please Read Carefully:

Information in this document is provided solely in connection with ST products. STMicroelectronics NV and its subsidiaries ("ST") reserve the right to make changes, corrections, modifications or improvements, to this document, and the products and services described herein at any time, without notice.

All ST products are sold pursuant to ST's terms and conditions of sale.

Purchasers are solely responsible for the choice, selection and use of the ST products and services described herein, and ST assumes no liability whatsoever relating to the choice, selection or use of the ST products and services described herein.

No license, express or implied, by estoppel or otherwise, to any intellectual property rights is granted under this document. If any part of this document refers to any third party products or services it shall not be deemed a license grant by ST for the use of such third party products or services, or any intellectual property contained therein or considered as a warranty covering the use in any manner whatsoever of such third party products or services or any intellectual property contained therein.

UNLESS OTHERWISE SET FORTH IN ST'S TERMS AND CONDITIONS OF SALE ST DISCLAIMS ANY EXPRESS OR IMPLIED WARRANTY WITH RESPECT TO THE USE AND/OR SALE OF ST PRODUCTS INCLUDING WITHOUT LIMITATION IMPLIED WARRANTIES OF MERCHANTABILITY, FITNESS FOR A PARTICULAR PURPOSE (AND THEIR EQUIVALENTS UNDER THE LAWS OF ANY JURISDICTION), OR INFRINGEMENT OF ANY PATENT, COPYRIGHT OR OTHER INTELLECTUAL PROPERTY RIGHT.

UNLESS EXPRESSLY APPROVED IN WRITING BY AN AUTHORIZED ST REPRESENTATIVE, ST PRODUCTS ARE NOT RECOMMENDED, AUTHORIZED OR WARRANTED FOR USE IN MILITARY, AIR CRAFT, SPACE, LIFE SAVING, OR LIFE SUSTAINING APPLICATIONS, NOR IN PRODUCTS OR SYSTEMS WHERE FAILURE OR MALFUNCTION MAY RESULT IN PERSONAL INJURY, DEATH, OR SEVERE PROPERTY OR ENVIRONMENTAL DAMAGE. ST PRODUCTS WHICH ARE NOT SPECIFIED AS "AUTOMOTIVE GRADE" MAY ONLY BE USED IN AUTOMOTIVE APPLICATIONS AT USER'S OWN RISK.

Resale of ST products with provisions different from the statements and/or technical features set forth in this document shall immediately void any warranty granted by ST for the ST product or service described herein and shall not create or extend in any manner whatsoever, any liability of ST.

ST and the ST logo are trademarks or registered trademarks of ST in various countries.

Information in this document supersedes and replaces all information previously supplied.

The ST logo is a registered trademark of STMicroelectronics. All other names are the property of their respective owners.



© 2008 STMicroelectronics - All rights reserved

STMicroelectronics group of companies

Australia - Belgium - Brazil - Canada - China - Czech Republic - Finland - France - Germany - Hong Kong - India - Israel - Italy - Japan - Malaysia - Malta - Morocco - Singapore - Spain - Sweden - Switzerland - United Kingdom - United States of America

www.st.com

