

Applications

- Overcurrent and short-circuit protection

Features

- Lead-free terminals
- Manufacturer's logo and type designation stamped on
- Short response times
- Reduced device temperature at V_{max}
- Type C 860, C 870 and C 890 also available with insulating voltage test to IEC 60738-1
- UL approval for $T_{Ref} = 130\text{ °C}$ to UL 1434 with $V_{max} = 220\text{ V}$ and $V_N = 220\text{ V}$ (file number E69802), except C 810 and PTCs with insulating voltage test
- UL approval for $T_{Ref} = 120\text{ °C}$ to UL 1434 with $V_{max} = 230\text{ V}$ and $V_N = 220\text{ V}$ (file number E69802), except for PTCs with insulating voltage test
- VDE approval (license number 104843 E), except PTCs with insulating voltage test (VDE pending) and C 810

Options

- Leadless disks and leaded disks without coating available on request
- Thermistors with diameter $b \leq 11,0\text{ mm}$ are also available on tape (to IEC 60286-2)

Delivery mode

- Cardboard strips (standard)
- Cardboard tape reeled or in AMMO pack on request

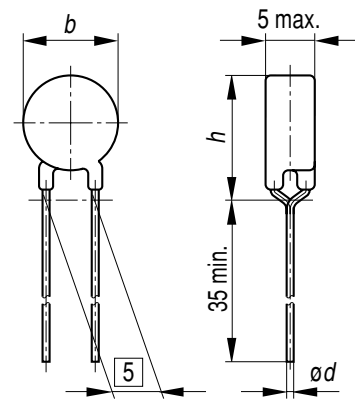

TPT0648-4

Dimensions (mm)

Type	T_{Ref}	b_{max}	$\varnothing d$	h_{max}
C 810	130 °C	22,0	0,8	25,5
C 830	80/120 °C	22,0	0,6	25,5
C 830	130 °C	17,5	0,8	21,0
C 840	80/120 °C	17,5	0,6	21,0
C 840	130 °C	13,5	0,6	17,0
C 850	80/120 °C	13,5	0,6	17,0
C 850	130 °C	11,0	0,6	14,5
C 860	80/120 °C	11,0	0,6	14,5
C 860	130 °C	9,0	0,6	12,5
C 870	80/120 °C	9,0	0,6	12,5
C 870	130 °C	6,5	0,6	10,0
C 872	120 °C	9,0	0,6	12,5
C 873	120 °C	9,0	0,6	12,5
C 874	120 °C	9,0	0,6	12,5
C 875	120 °C	9,0	0,6	12,5
C 880	80/120 °C	6,5	0,6	10,0
C 880	130 °C	4,0	0,6	7,5
C 883	120 °C	6,5	0,6	10,0
C 890	80/120 °C	4,0	0,5	7,5

General technical data

Max. operating voltage ($T_A = 60\text{ °C}$)	V_{max}	265	VDC or VAC
Rated voltage	V_N	230	VDC or VAC
Switching cycles (typ.)	N	100	
Resistance tolerance	ΔR_N	± 25 % for $T_{Ref} = 80\text{ °C}$ or 120 °C ± 20 % for $T_{Ref} = 130\text{ °C}$	
Operating temperature range ($V = 0$)	T_{op}	- 40/+ 125	°C
	T_{op}	0/+ 60	°C

Electrical specifications and ordering codes

Type	I_N mA	I_S mA	I_{Smax} ($V=V_{max}$) A	I_r (typ.) ($V=V_{max}$) mA	T_{ref} °C	R_N Ω	R_{min} Ω	Ordering code
C 810	650	980	7,0	20	130	3,5	2,3	B59810C0130A070
C 830	460	920	7,0	20	120	3,7	2,4	B59830C0120A070
C 830	450	680	4,1	15	130	5	3,3	B59830C0130A070
C 840	330	660	4,1	15	120	6	3,8	B59840C0120A070
C 840	330	500	2,2	13	130	9	5,9	B59840C0130A070
C 830	250	510	7,0	15	80	3,7	2,2	B59830C0080A070
C 850	200	400	2,2	13	120	10	6,4	B59850C0120A070
C 850	200	320	1,5	10	130	13	8,6	B59850C0130A070
C 840	170	350	4,1	10	80	6	3,6	B59840C0080A070
C 860	140	280	1,5	10	120	15	9,0	B59860C0120A070
C 860	140	230	1,0	9	130	25	16,5	B59860C0130A070
C 850	110	230	2,2	8	80	10	6,0	B59850C0080A070
C 870	100	200	1,0	9	120	25	15	B59870C0120A070
C 870	100	150	0,4	6	130	50	33	B59870C0130A070
C 860	90	180	1,5	6	80	15	7,8	B59860C0080A070
C 872	80	160	1,0	9	120	35	21	B59872C0120A070
C 873	70	140	1,0	9	120	45	27	B59873C0120A070
C 874	60	125	1,0	9	120	55	31	B59874C0120A070
C 870	60	130	1,0	5	80	25	13,1	B59870C0080A070
C 880	55	110	0,4	6	120	70	39	B59880C0120A070
C 875	55	110	1,0	9	120	65	36	B59875C0120A070
C 880	55	90	0,2	5	130	160	106	B59880C0130A070
C 883	35	70	0,4	5	120	120	67	B59883C0120A070
C 890	30	60	0,2	5	120	150	84	B59890C0120A070
C 880	30	70	0,4	4	80	70	36,7	B59880C0080A070
C 890	15	40	0,2	3	80	150	78,7	B59890C0080A070
<i>Insulating voltage test (265 V_{rms})</i>								
C 860	140	280	1,5	10	120	15	9,0	B59860C0120A470 ¹⁾
C 870	100	200	1,0	9	120	25	15	B59870C0120A470 ¹⁾
C 890	30	60	0,2	5	120	150	84	B59890C0120A470 ¹⁾

1) Insulating voltage test (265 V_{rms}) to IEC 60738-1, chapter 4.8, metall ball method.

Reliability data

Test	Standard	Test conditions	$ \Delta R_{25}/R_{25} $
Switching test at room temperature	IEC 60738-1	I_{Smax} V_{max} Number of cycles: 100	< 25%
Dry heat at upper category temperature	IEC 60738-1	Storage at upper category temperature for t : 1000 h	< 25%
Life test at V_{max}/T_{op}	IEC 60738-1	Storage at V_{max}/T_{op} for t : 1000 h	< 25%
Storage in damp heat	IEC 60068-2-3	Temperature of air: 40 °C Relative humidity of air: 93% Duration: 56 days	< 10%
Rapid change of temperature in air	IEC 60068-2-14, Test N_a	$T = T_{LCT}$, $T = T_{UCT}$ Number of cycles: 5 t : 30 min	< 10%
Vibration	IEC 60068-2-6, Test F_C	$f = 10-55$ Hz $h = 0,75$ mm (respectively 10 g) t : 3 · 2 h	< 5%
Bump	IEC 60068-2-27	Pulse shape: half-sine $a = 50$ g Pulse duration: 1 ms; 6 · 3 pulses	< 5%
Climatic sequence	IEC 60068-2-30	Dry heat: $T = T_{UCT}$ t : 16 h Damp heat first cycle Cold: $T = T_{LCT}$ t : 2 h Damp heat 5 cycles	< 10%

Characteristics (typical) for $T_{Ref} = 80\text{ }^{\circ}\text{C}$

PTC resistance R_{PTC} versus
PTC temperature T_{PTC}
(measured at low signal voltage)

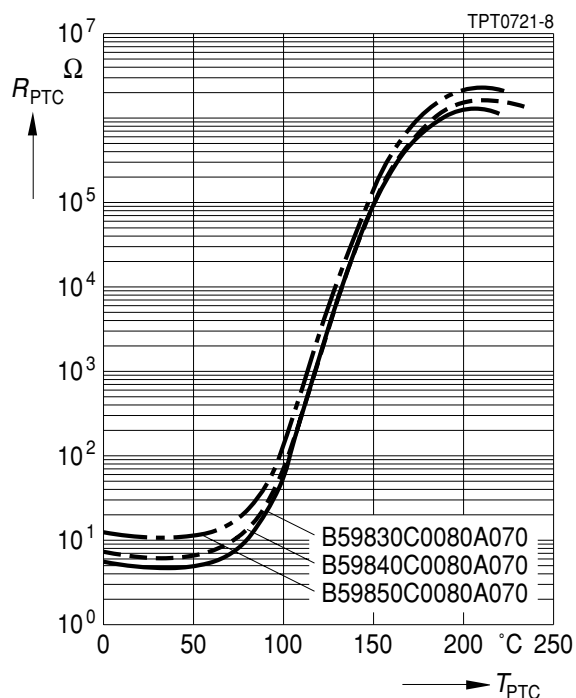

PTC current I_{PTC} versus PTC voltage V_{PTC}
(measured at $25\text{ }^{\circ}\text{C}$ in still air)

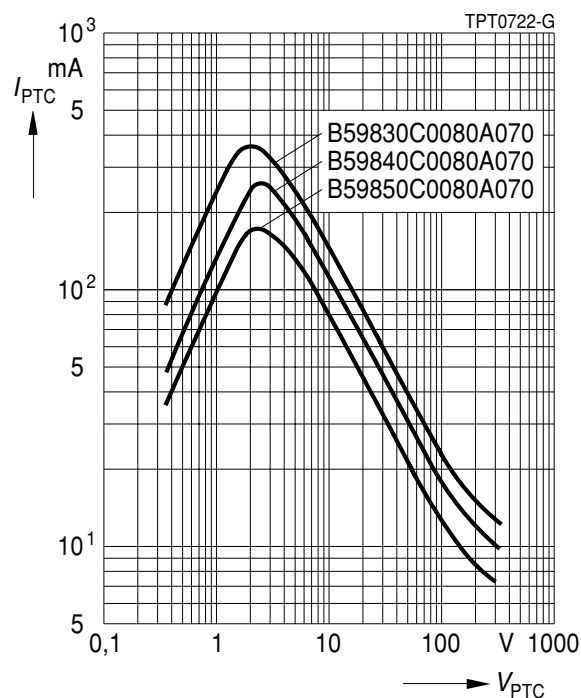

Switching time t_S versus switching current I_S
(measured at $25\text{ }^{\circ}\text{C}$ in still air)

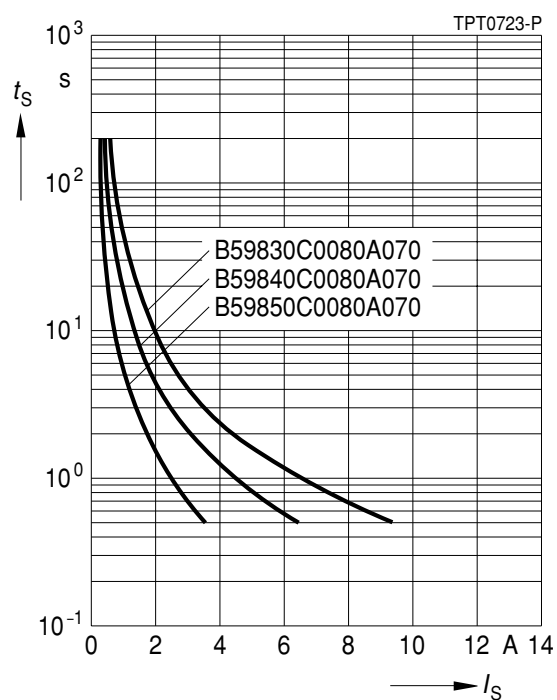

Rated current I_N versus ambient temperature T_A
(measured in still air)

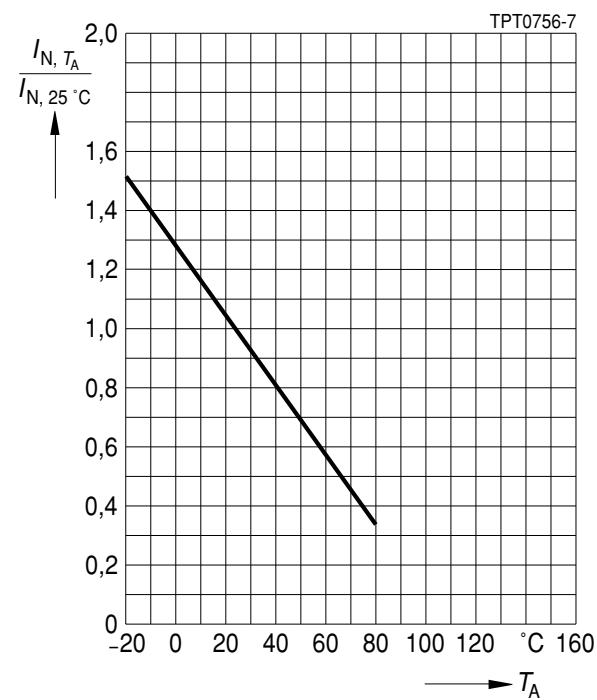

Characteristics (typical) for $T_{Ref} = 80\text{ °C}$

PTC resistance R_{PTC} versus
PTC temperature T_{PTC}
(measured at low signal voltage)

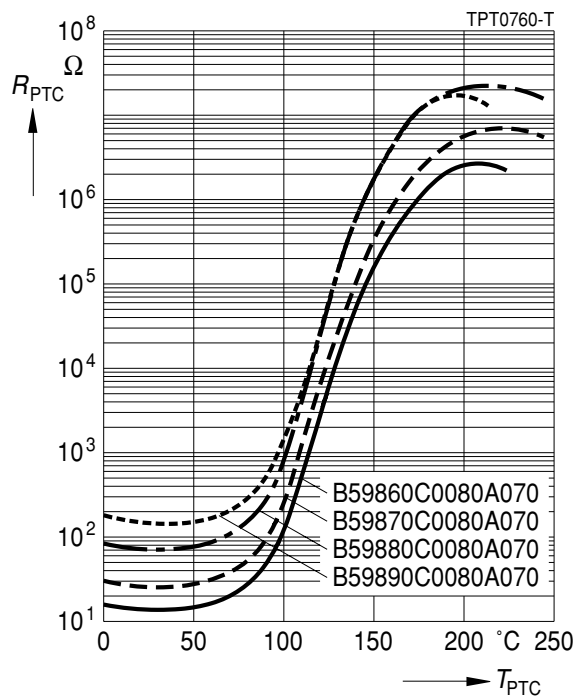

PTC current I_{PTC} versus PTC voltage V_{PTC}
(measured at 25 $^{\circ}\text{C}$ in still air)

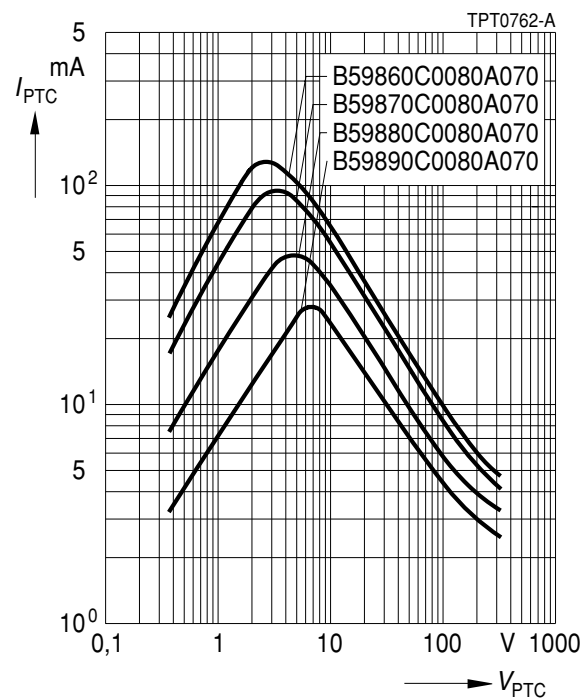

Switching time t_S versus switching current I_S
(measured at 25 $^{\circ}\text{C}$ in still air)

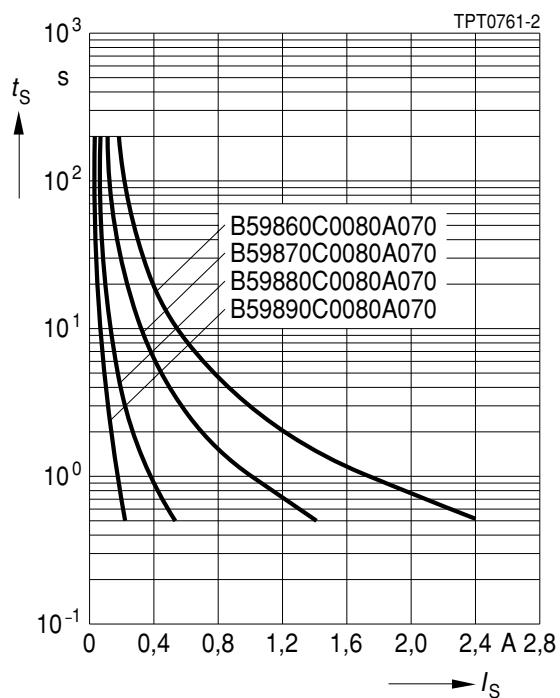

Rated current I_N versus ambient temperature T_A
(measured in still air)

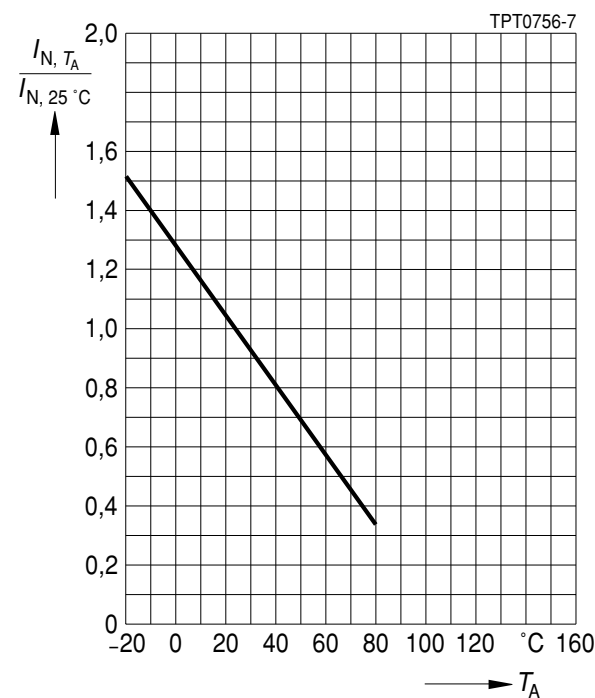

Characteristics (typical) for $T_{Ref} = 120\text{ }^\circ\text{C}$

PTC resistance R_{PTC} versus
PTC temperature T_{PTC}
(measured at low signal voltage)

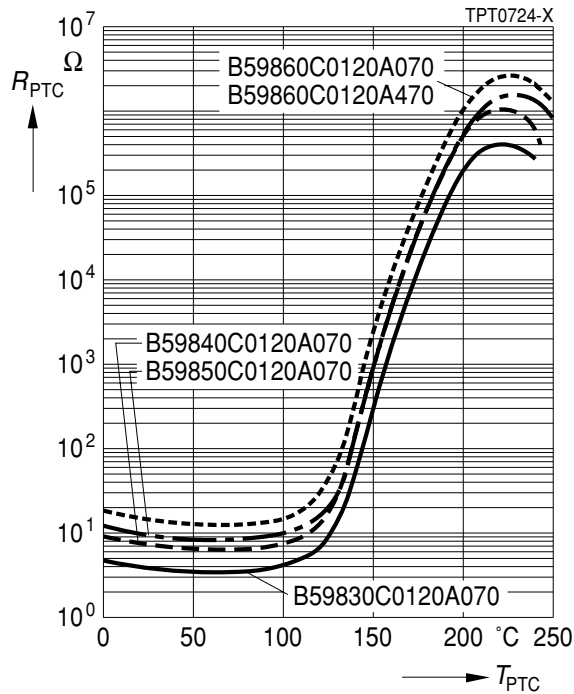

PTC current I_{PTC} versus PTC voltage V_{PTC}
(measured at $25\text{ }^\circ\text{C}$ in still air)

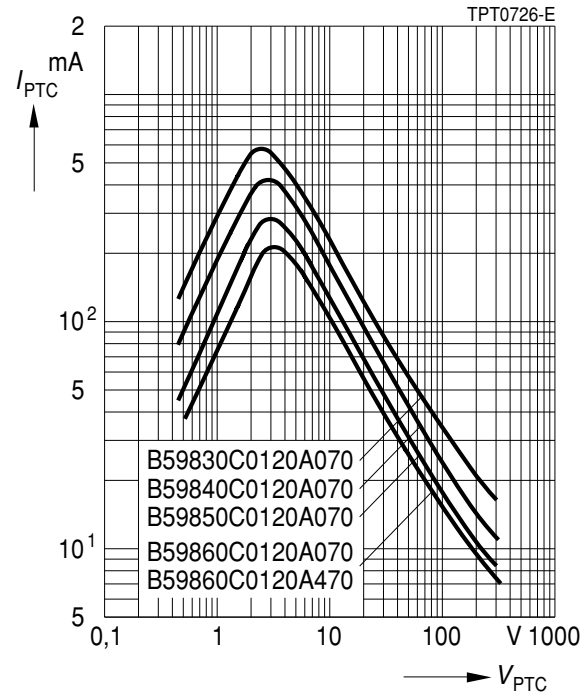

Switching time t_S versus switching current I_S
(measured at $25\text{ }^\circ\text{C}$ in still air)

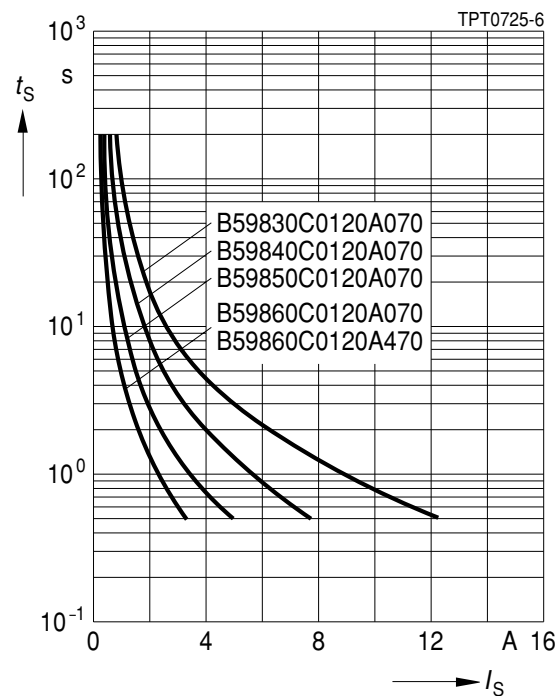

Rated current I_N versus ambient temperature T_A
(measured in still air)

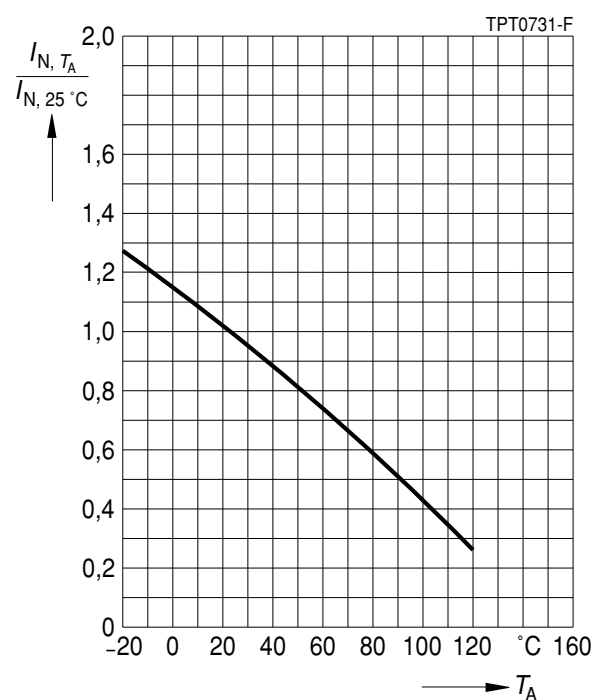

Characteristics (typical) for $T_{Ref} = 120\text{ }^{\circ}\text{C}$

PTC resistance R_{PTC} versus
PTC temperature T_{PTC}
(measured at low signal voltage)

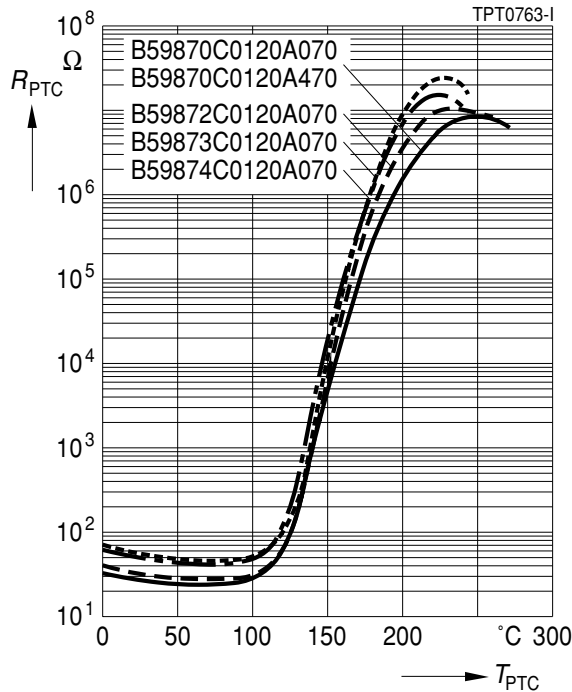

PTC current I_{PTC} versus PTC voltage V_{PTC}
(measured at $25\text{ }^{\circ}\text{C}$ in still air)

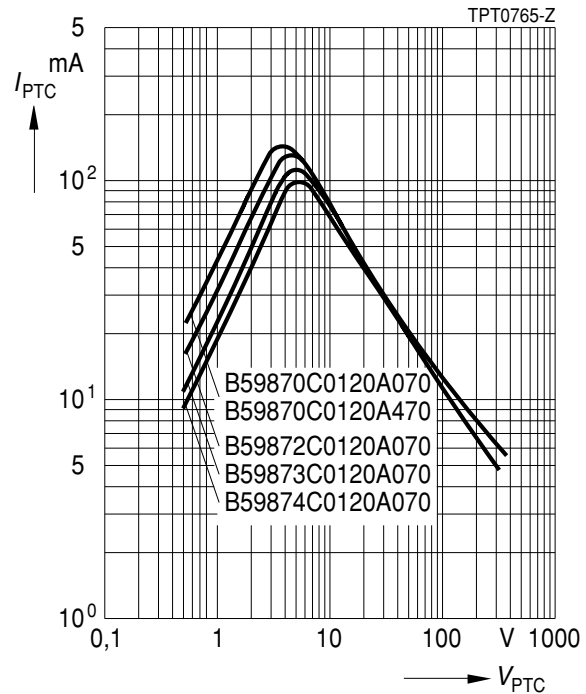

Switching time t_S versus switching current I_S
(measured at $25\text{ }^{\circ}\text{C}$ in still air)

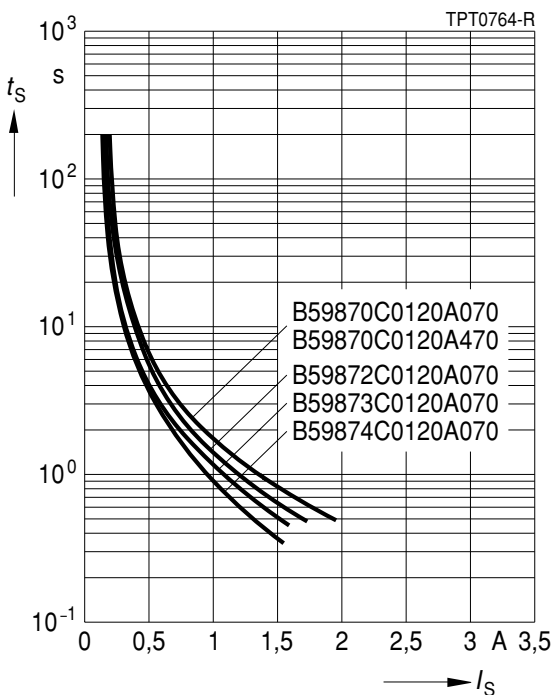

Rated current I_N versus ambient temperature T_A
(measured in still air)

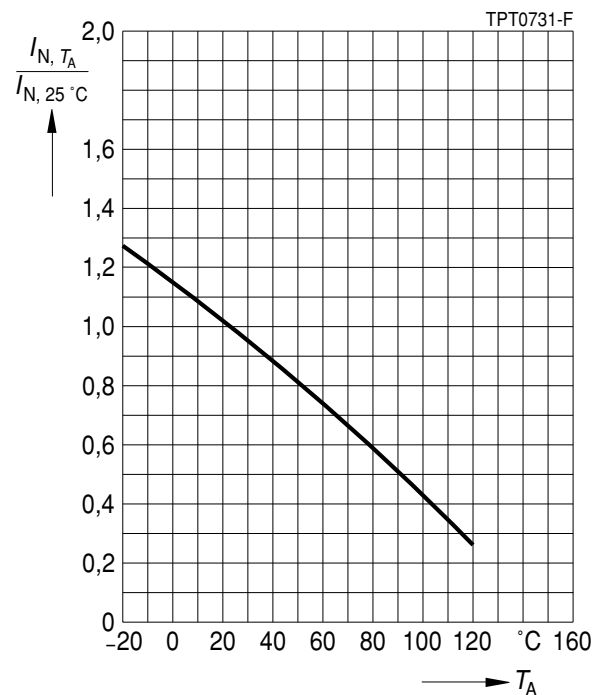

Characteristics (typical) for $T_{Ref} = 120\text{ }^{\circ}\text{C}$

PTC resistance R_{PTC} versus
PTC temperature T_{PTC}
(measured at low signal voltage)

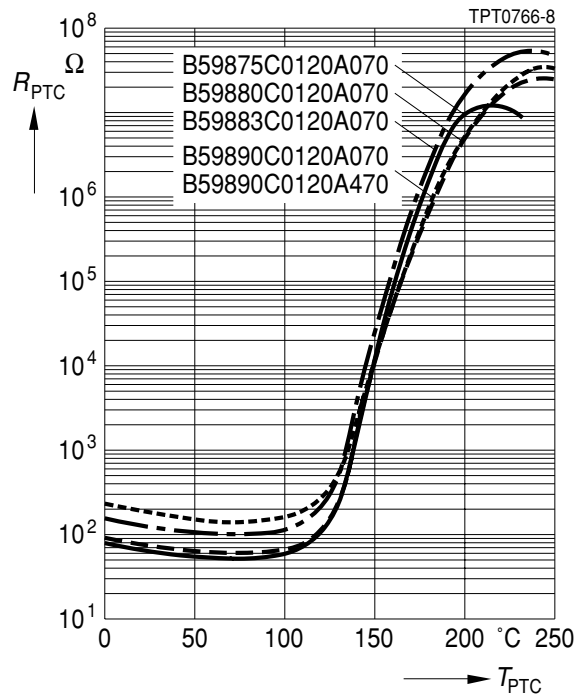

PTC current I_{PTC} versus PTC voltage V_{PTC}
(measured at $25\text{ }^{\circ}\text{C}$ in still air)

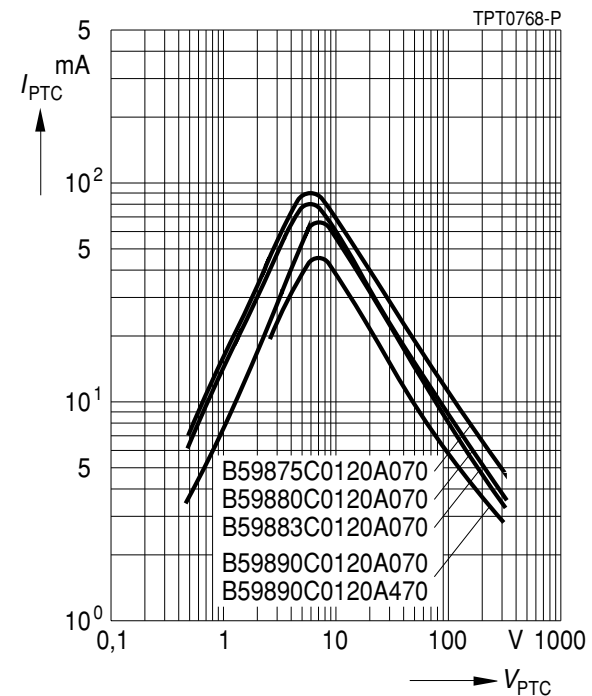

Switching time t_S versus switching current I_S
(measured at $25\text{ }^{\circ}\text{C}$ in still air)

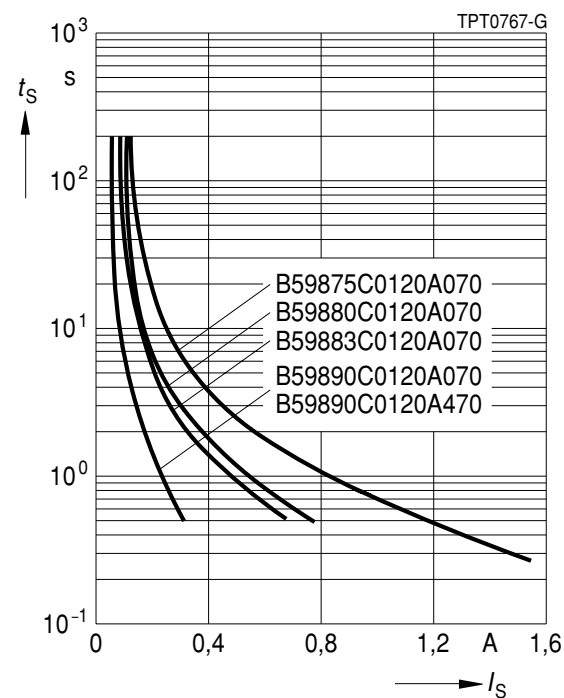

Rated current I_N versus ambient temperature T_A
(measured in still air)

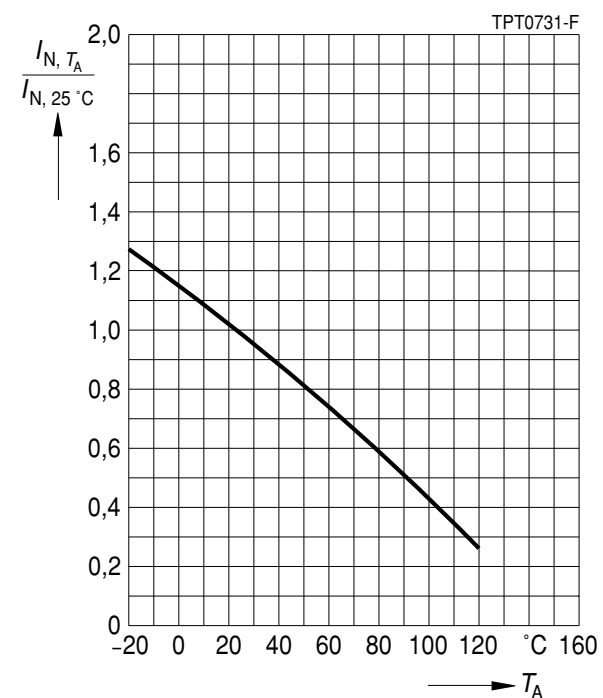

Characteristics (typical) for $T_{Ref} = 130\text{ }^{\circ}\text{C}$

PTC resistance R_{PTC} versus
PTC temperature T_{PTC}
(measured at low signal voltage)

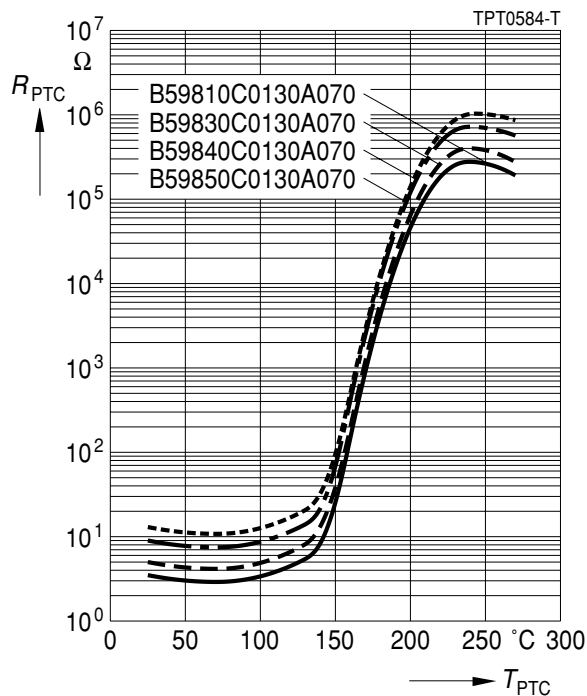

PTC current I_{PTC} versus PTC voltage V_{PTC}
(measured at $25\text{ }^{\circ}\text{C}$ in still air)

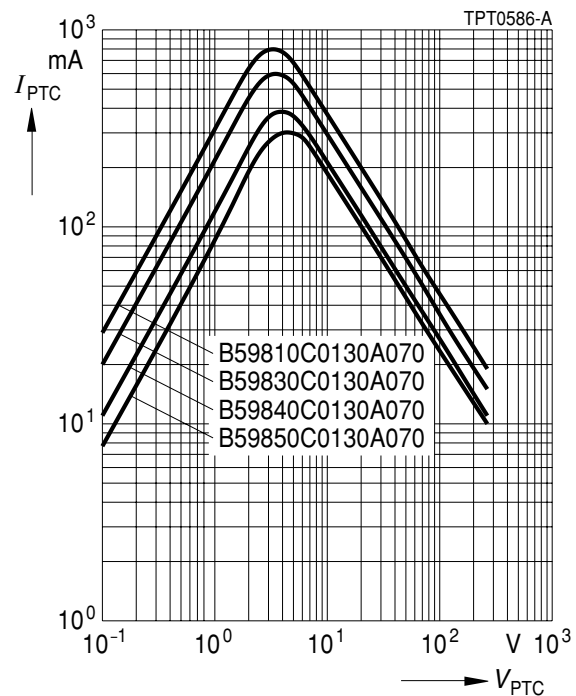

Switching time t_S versus switching current I_S
(measured at $25\text{ }^{\circ}\text{C}$ in still air)

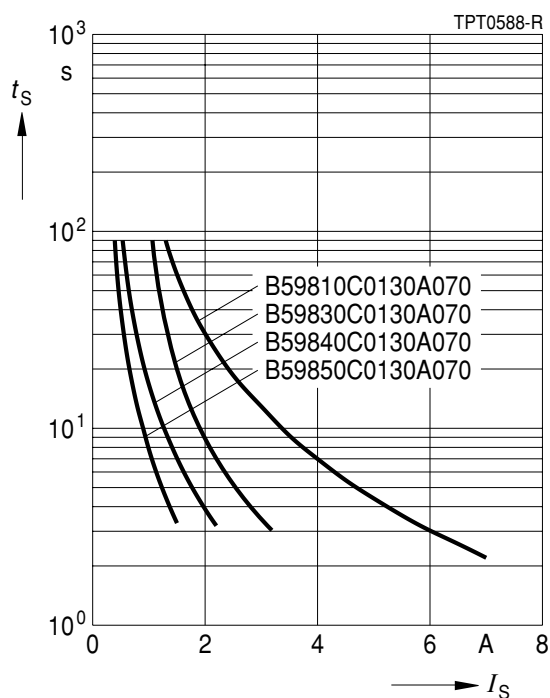

Rated current I_N versus ambient temperature T_A
(measured in still air)

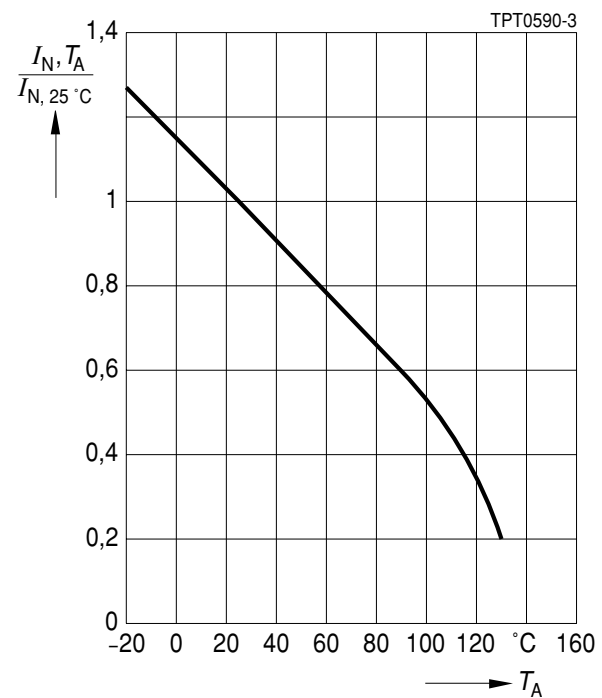

Characteristics (typical) for $T_{Ref} = 130\text{ }^{\circ}\text{C}$

PTC resistance R_{PTC} versus
PTC temperature T_{PTC}
(measured at low signal voltage)

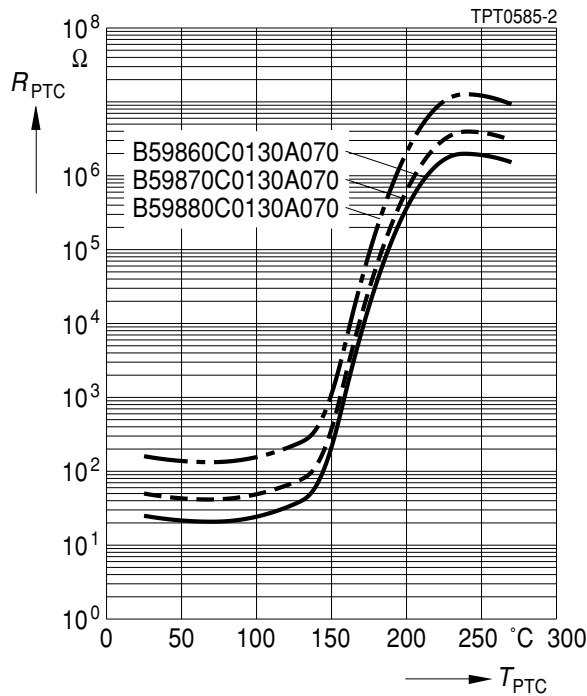

PTC current I_{PTC} versus PTC voltage V_{PTC}
(measured at 25 °C in still air)

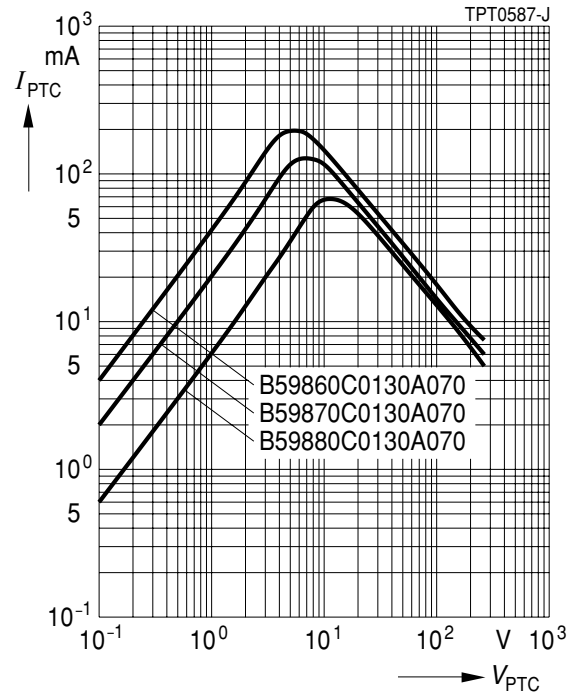

Switching time t_S versus switching current I_S
(measured at 25 °C in still air)

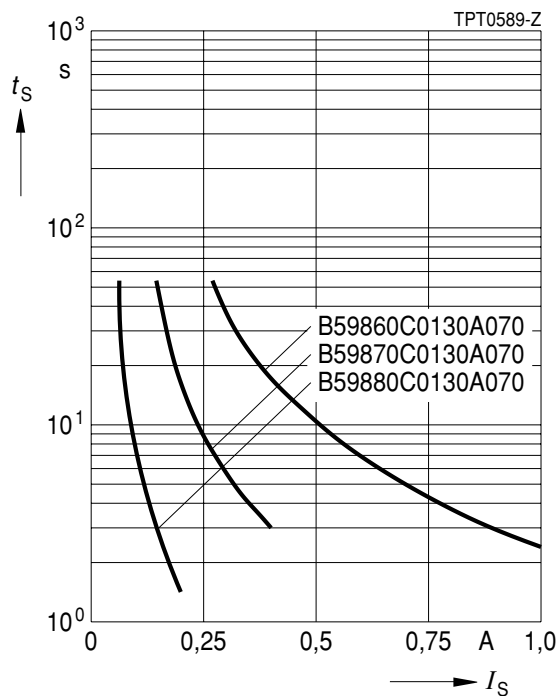

Rated current I_N versus ambient temperature T_A
(measured in still air)

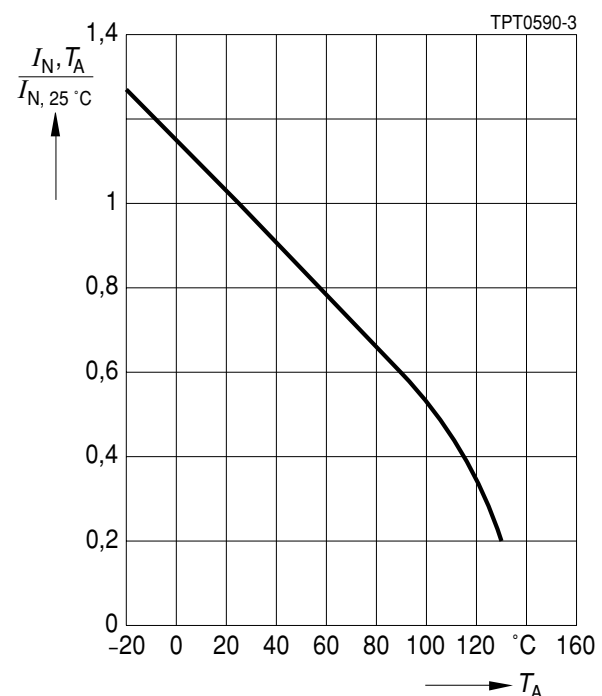

Herausgegeben von EPCOS AG

Unternehmenskommunikation, Postfach 80 17 09, 81617 München, DEUTSCHLAND

☎ ++49 89 636 09, FAX (0 89) 636-2 26 89

© EPCOS AG 2002. Vervielfältigung, Veröffentlichung, Verbreitung und Verwertung dieser Broschüre und ihres Inhalts ohne ausdrückliche Genehmigung der EPCOS AG nicht gestattet.

Bestellungen unterliegen den vom ZVEI empfohlenen Allgemeinen Lieferbedingungen für Erzeugnisse und Leistungen der Elektroindustrie, soweit nichts anderes vereinbart wird.

Diese Broschüre ersetzt die vorige Ausgabe.

Fragen über Technik, Preise und Liefermöglichkeiten richten Sie bitte an den Ihnen nächstgelegenen Vertrieb der EPCOS AG oder an unsere Vertriebsgesellschaften im Ausland. Bauelemente können aufgrund technischer Erfordernisse Gefahrstoffe enthalten. Auskünfte darüber bitten wir unter Angabe des betreffenden Typs ebenfalls über die zuständige Vertriebsgesellschaft einzuholen.

Published by EPCOS AG

Corporate Communications, P.O. Box 80 17 09, 81617 Munich, GERMANY

☎ ++49 89 636 09, FAX (0 89) 636-2 26 89

© EPCOS AG 2002. Reproduction, publication and dissemination of this brochure and the information contained therein without EPCOS' prior express consent is prohibited.

Purchase orders are subject to the General Conditions for the Supply of Products and Services of the Electrical and Electronics Industry recommended by the ZVEI (German Electrical and Electronic Manufacturers' Association), unless otherwise agreed.

This brochure replaces the previous edition.

For questions on technology, prices and delivery please contact the Sales Offices of EPCOS AG or the international Representatives.

Due to technical requirements components may contain dangerous substances. For information on the type in question please also contact one of our Sales Offices.