

Multilayer Varistor for ESD pulse

Series **EZJZ** : For high speed signal line
(ZnO:Zinc Oxide) (Small capacitance)

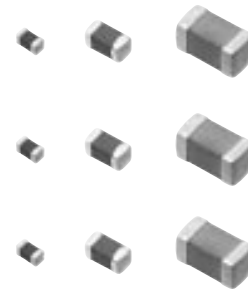

■ Features

- Multilayer monolithic ceramic construction
- Excellent solderability and superior heat resistance
- Large surge current and energy capabilities in withstanding small size.

● Series EZJZ

- Multilayer varistor of Zinc oxide ceramic. suppresses the pulse noise(ESD, burst-noise) and protects the equipment from the transient surge.
- This Varistor is suitable for high-speed signal line due to small capacitance.

■ Precautions for Handling

see Page 112 to 118

■ Packing method

see Page 111, 182

■ Explanation of Part Numbers

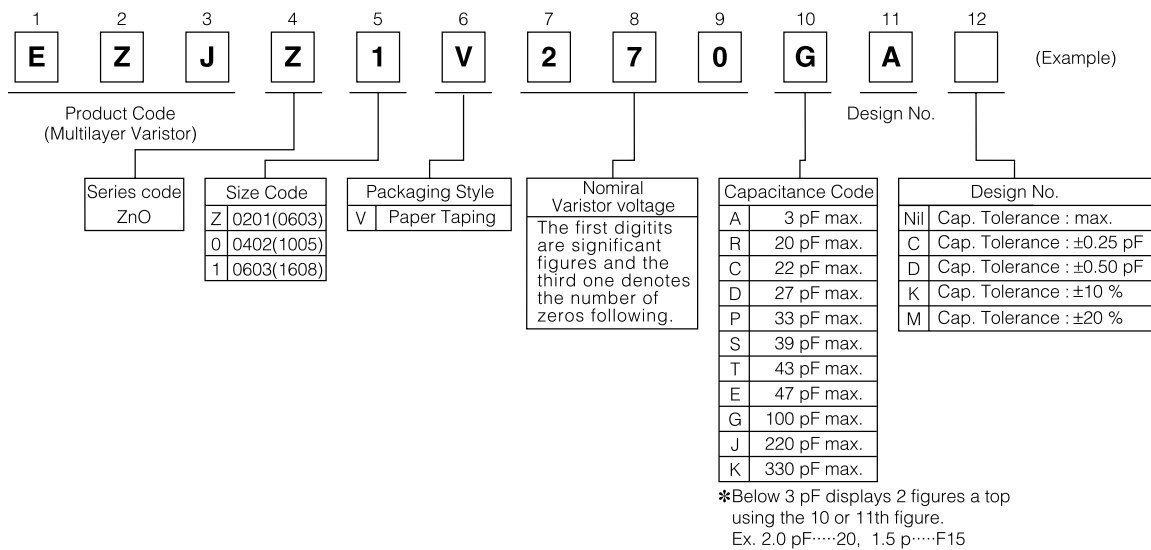

■ Construction

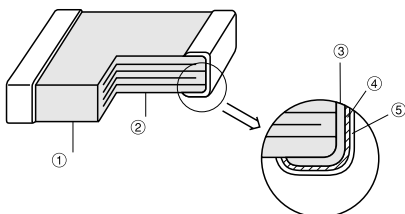

No	Name
①	Semiconductive Ceramics
②	Inner electrode
③	Substrate electrode
④	Intermediate electrode
⑤	External electrode

Design and specifications are each subject to change without notice. Ask factory for the current technical specifications before purchase and/or use. Should a safety concern arise regarding this product, please be sure to contact us immediately.

■ Dimension in mm(not to scale)

(Unit:mm)

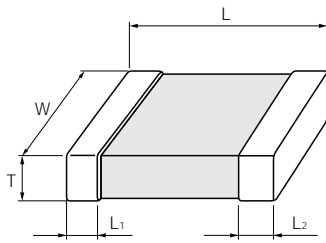

Size Code (EIA)	Part Numbers	L	W	T	L1, L2
0201	EZJZ□□□□□A	0.60±0.03	0.30±0.03	0.30±0.03	0.15±0.05
0402	EZJZ0□□□□□A	1.00±0.50	0.50±0.05	0.50±0.05	0.2±0.1
0603	EZJZ1□□□□□A	1.6±0.1	0.8±0.1	0.8±0.1	0.3±0.2

■ Ratings and Characteristics

Type	Size Code (EIA)	Part No.	Maximum Allowable Voltage	Varistor Voltage @ 1mA	Capacitance @ 1 MHz	Maximum Peak Current @ 8/20 μs	Maximum ESD IEC61000-4-2
Ultra low capacitance	0201	EZJZV800AA	DC 5 V	80 V	3 pF max.	—	Contact Discharge Voltage: 8 kV Air Gap Discharge Voltage: 15 kV
		0402	EZJZ0V80015D	DC 5 V	80 V	1.5±0.5 pF	
	EZJZ0V500AA		DC 5 V	50 V	3 pF max.	—	
	EZJZ0V800AA		DC 18 V	80 V	3 pF max.	—	
	EZJZ0V171AA		DC 18 V	170 V	3 pF max.	—	
	EZJZ1V500AA		DC 5 V	50 V	3 pF max.	—	
	0603	EZJZ1V800AA	DC 18 V	80 V	3 pF max.	—	
EZJZ1V171AA		DC 18 V	170 V	3 pF max.	—		
Low capacitance	0201	EZJZV120EA	DC 6.7 V	12 V	47 pF max.	1 A	
		EZJZV270RA	DC 16 V	27 V	20 pF max.	1 A	
	0402	EZJZ0V120JA	DC 6.7 V	12 V	220 pF max.	10 A	
		EZJZ0V270RA	DC 16 V	27 V	20 pF max.	3 A	
		EZJZ0V270EA	DC 16 V	27 V	47 pF max.	10 A	
	0603	EZJZ1V120KA	DC 6.7 V	12 V	330 pF max.	20 A	
		EZJZ1V270GA	DC 16 V	27 V	100 pF max.	20 A	
		EZJZ1V330GA	DC 26 V	33 V	100 pF max.	20 A	

● Operating Temperature Range: -40 to 85 °C

■ Typical Characteristics

● Voltage vs. Current

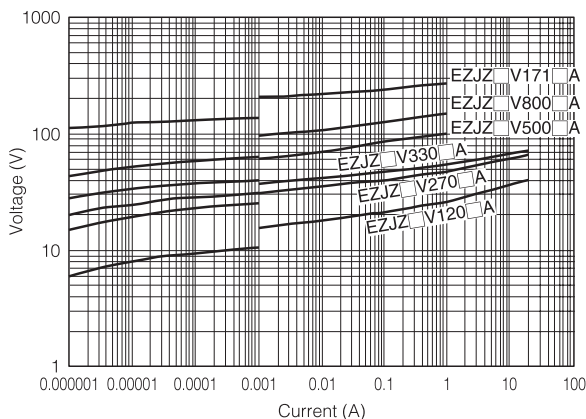

■ Frequency Characteristics

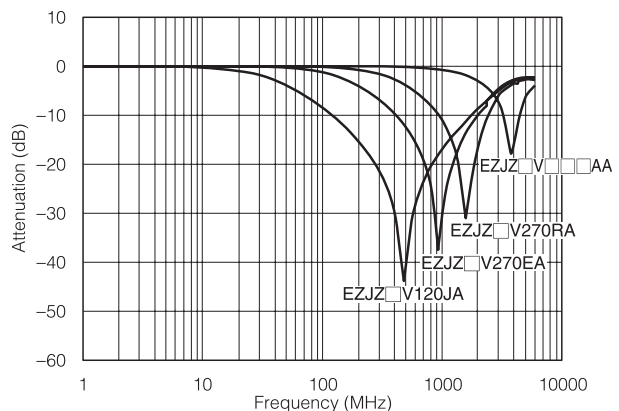

Design and specifications are each subject to change without notice. Ask factory for the current technical specifications before purchase and/or use. Should a safety concern arise regarding this product, please be sure to contact us immediately.

■ Packaging Specifications
● Standard Packing Quantity

Series	Size Code (EIA)	Thickness	Paper taping	Embossed taping
EZJZ	0201	0.3 mm	Pitch: 2 mm 15,000 pcs./reel	—
	0402	0.5 mm	Pitch: 2 mm 10,000 pcs./reel	—
	0603	0.8 mm	Pitch: 4 mm 4,000 pcs./reel	—
	2 Array Type	0.6 mm	Pitch: 4 mm 4,000 pcs./reel	—
	4 Array Type	0.85 mm	Pitch: 4 mm 4,000 pcs./reel	—
EZJS	0603	0.8 mm	Pitch: 4 mm 4,000 pcs./reel	—
	0805	0.8 mm	Pitch: 4 mm 5,000 pcs./reel	—
		1.25 mm	—	Pitch: 4 mm 2,000 pcs./reel

● Paper Taping
P₁: 2mm

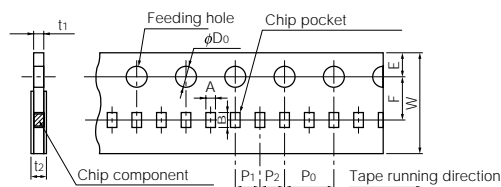

(Unit: mm)

Symbol	A	B	W	F	E	P ₁	P ₂	P ₀	φD	t ₁	t ₂
0201	0.37 ±0.03	0.67 ±0.03	8.0 ±0.2	3.50 ±0.05	1.75 ±0.10	2.00 ±0.05	2.00 ±0.05	4.0 ±0.05	1.5 +0.1 0	0.5 max.	0.8 max.
0402	0.62 ±0.05	1.12 ±0.05	8.0 ±0.2	3.50 ±0.05	1.75 ±0.10	2.00 ±0.05	2.00 ±0.05	4.0 ±0.05	1.5 +0.1 0	0.7 max.	1.0 max.

P₁: 4mm

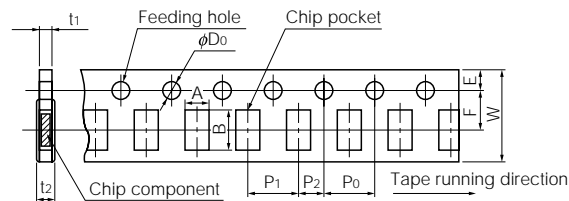

(Unit: mm)

Symbol	A	B	W	F	E	P ₁	P ₂	P ₀	φD	t ₁	t ₂
0603	1.18 ±0.10	1.63 ±0.10	8.0 ±0.2	3.50 ±0.05	1.75 ±0.10	4.0 ±0.1	2.00 ±0.05	4.0 ±0.1 0	1.5 +0.1	1.1 max.	1.4 max.
0805 4 Array Type	1.65 ±0.2	2.4 ±0.2	8.0 ±0.2	3.50 ±0.05	1.75 ±0.10	4.0 ±0.1	2.00 ±0.05	4.0 ±0.1 0	1.5 +0.1	1.1 max.	1.4 max.
0504 2 Array Type	1.0 ±0.1	1.8 ±0.1	8.0 ±0.2	3.50 ±0.05	1.75 ±0.10	4.0 ±0.1	2.00 ±0.05	4.0 ±0.1 0	1.5 +0.1	1.1 max.	1.4 max.

● Embossed Taping

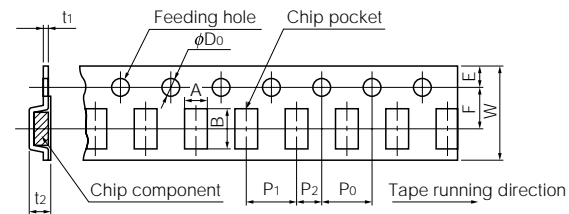

(Unit: mm)

Symbol	A	B	W	F	E	P ₁	P ₂	P ₀	φD	t ₁	t ₂
0805	1.55 ±0.20	2.35 ±0.20	8.0 ±0.2	3.50 ±0.05	1.75 ±0.10	4.0 ±0.1	2.00 ±0.05	4.0 ±0.1	1.5 +0.1 0	0.6 max.	1.5 max.

● Reel

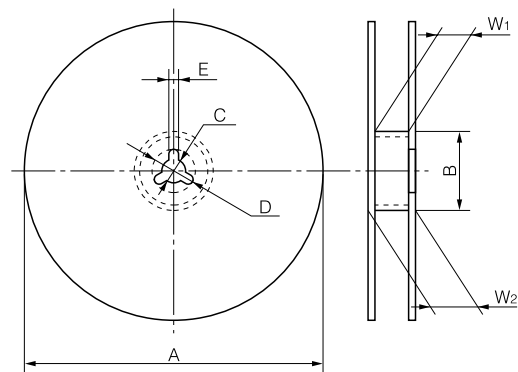

Symbol	A	B	C	D	E	W ₁	W ₂
Dim. (mm)	φ180 ⁺⁰ ₋₁	φ60.0±0.5	13.0±0.5	21.0±0.8	2.0±0.5	9.0±0.3	11.4±1.00

● Leader Part and Taped End
Tape end

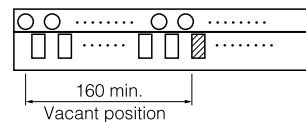

Leader part

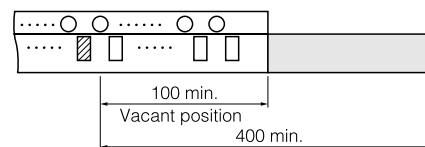

Unit : mm

Design and specifications are each subject to change without notice. Ask factory for the current technical specifications before purchase and/or use. Should a safety concern arise regarding this product, please be sure to contact us immediately.