

# NTC SMD Thermistors



## NC 12 – NC 20

Chip thermistors are a high quality and low cost device especially developed for surface mounting applications. They are widely used for temperature compensation but can also achieve temperature control of printed circuits. Its silver -

palladium - platinum metallization provides a high degree of resistance to dewetting of the terminations during soldering (typically 260°C / 30 s).

Types	NC 12 IEC SIZE : 0805	NC 20 IEC SIZE : 1206
<b>DIMENSIONS: millimeters (inches)</b>		
Terminations	Silver – palladium – platinum metallization	
Marking	On packaging only	
Climatic category	40/125/56	
Operating temperature	-55°C to +150°C	
Tolerance on R <sub>n</sub> (25°C)	±5%, ±10%, ±20%	
Maximum dissipation at 25°C	0.12 W	0.24 W
Thermal dissipation factor	2 mW/°C	4 mW/°C
Thermal time constant	5 s	7 s

Resistance - Temperature characteristics: pages 36 to 40.

## APPLICATIONS

- LCD compensation
- Battery packs
- Mobile phones
- CD players
- Heating systems
- Air-conditioning systems
- Temperature control of Switch Mode Power Supplies
- Compensation of pressure sensors
- Protection of power transistors in various electronic circuits

## HOW TO ORDER

**NC 20**

Type

**K 0**

Material Code

K  
(See tables pages 11, 36-40)

**0103**

Resistance  
10,000 Ω

**M**

Tolerance  
M (±20%)  
J (±5%)  
K (±10%)

**BA**

Suffix: Packaging  
--: Bulk  
BA: Plastic tape  
(180mm diam. reel)  
BE: Plastic tape (1/2 reel)  
BC: Plastic tape  
(330mm diam. reel)  
BB: Cardboard tape  
(180mm diam. reel)  
BF: Cardboard tape (1/2 reel)  
BD: Cardboard tape  
(330mm diam. reel)



# NTC SMD Thermistors



## NC 12 – NC 20

### TABLE OF VALUES

NC 12 IEC SIZE : 0805				
Types	Rn at 25°C (Ω)	Material Code	B (K) ( $\frac{\Delta B}{B}$ (1) ± 5% (2) ± 3%)	α at 25°C (%/°C)
NC 12 KC 0 180	18	KC	3470 ± 5%	- 3.9
NC 12 KC 0 220	22			
NC 12 KC 0 270	27			
NC 12 KC 0 330	33			
NC 12 KC 0 390	39			
NC 12 KC 0 470	47			
NC 12 KC 0 560	56			
NC 12 KC 0 680	68			
NC 12 KC 0 820	82			
NC 12 KC 0 101	100			
NC 12 MC 0 121	120	MC	3910 ± 3%	- 4.4
NC 12 MC 0 151	150			
NC 12 MC 0 181	180			
NC 12 MC 0 221	220			
NC 12 MC 0 271	270			
NC 12 MC 0 331	330			
NC 12 MC 0 391	390			
NC 12 MC 0 471	470			
NC 12 MC 0 561	560			
NC 12 MC 0 681	680			
NC 12 MC 0 821	820			
NC 12 MC 0 102	1,000			
NC 12 MC 0 122	1,200			
NC 12 MC 0 152	1,500			
NC 12 MC 0 182	1,800			
NC 12 MC 0 222	2,200			
NC 12 MC 0 272	2,700			
NC 12 MC 0 332	3,300			
NC 12 J 0 0332	3,300	J	3480 ± 3%	- 3.9
NC 12 J 0 0392	3,900			
NC 12 J 0 0472	4,700			
NC 12 J 0 0562	5,600			
NC 12 K 0 0682	6,800	K	3630 ± 3%	- 4.0
NC 12 K 0 0822	8,200			
NC 12 K 0 0103	10,000			
NC 12 K 0 0123	12,000			
NC 12 L 0 0153	15,000	L	3790 ± 3%	- 4.2
NC 12 L 0 0183	18,000			
NC 12 M 0 0223	22,000	M	3950 ± 3%	- 4.4
NC 12 M 0 0273	27,000			
NC 12 M 0 0333	33,000			
NC 12 M 0 0393	39,000			
NC 12 N 0 0473	47,000	N	4080 ± 3%	- 4.6
NC 12 N 0 0563	56,000			
NC 12 L 2 0683	68,000	L2	3805 ± 3%	- 4.1
NC 12 N 0 0823	82,000	N	4080 ± 3%	- 4.6
NC 12 P 0 0104	100,000	P	4220 ± 3%	- 4.7
NC 12 P 0 0124	120,000			
NC 12 P 0 0154	150,000			
NC 12 P 0 0184	180,000			
NC 12 Q 0 0224	220,000			

NC 20 IEC SIZE : 1206							
Types	Rn at 25°C (Ω)	Material Code	B (K) ( $\frac{\Delta B}{B}$ (1) ± 5% (2) ± 3%)	α at 25°C (%/°C)			
NC 20 KC 0 100	10	KC	3470 ± 5%	- 3.9			
NC 20 KC 0 120	12						
NC 20 KC 0 150	15						
NC 20 KC 0 180	18						
NC 20 KC 0 220	22						
NC 20 KC 0 270	27						
NC 20 KC 0 330	33						
NC 20 KC 0 390	39						
NC 20 KC 0 470	47						
NC 20 KC 0 560	56						
NC 20 KC 0 680	68						
NC 20 KC 0 820	82						
NC 20 KC 0 101	100						
NC 20 MC 0 121	120	MC	3910 ± 3%	- 4.4			
NC 20 MC 0 151	150						
NC 20 MC 0 181	180						
NC 20 MC 0 221	220						
NC 20 MC 0 271	270						
NC 20 MC 0 331	330						
NC 20 MC 0 391	390						
NC 20 MC 0 471	470						
NC 20 MC 0 561	560						
NC 20 MC 0 681	680						
NC 20 MC 0 821	820						
NC 20 MC 0 102	1,000						
NC 20 MC 0 122	1,200						
NC 20 MC 0 152	1,500						
NC 20 I 0 0182	1,800				I	3250 ± 5%	- 3.7
NC 20 I 0 0222	2,200						
NC 20 I 0 0272	2,700						
NC 20 I 0 0332	3,300						
NC 20 J 0 0392	3,900	J	3480 ± 3%	- 3.9			
NC 20 J 0 0472	4,700						
NC 20 J 0 0562	5,600						
NC 20 J 0 0682	6,800						
NC 20 K 0 0822	8,200	K	3630 ± 3%	- 4.0			
NC 20 K 0 0103	10,000						
NC 20 K 0 0123	12,000						
NC 20 K 0 0153	15,000						
NC 20 L 0 0183	18,000	L	3790 ± 3%	- 4.2			
NC 20 L 0 0223	22,000						
NC 20 M 0 0273	27,000	M	3950 ± 3%	- 4.4			
NC 20 M 0 0333	33,000						
NC 20 M 0 0393	39,000						
NC 20 M 0 0473	47,000						
NC 20 N 0 0563	56,000	N	4080 ± 3%	- 4.6			
NC 20 N 0 0683	68,000						
NC 20 N 0 0823	82,000						
NC 20 N 0 0104	100,000						
NC 20 P 0 0124	120,000	P	4220 ± 3%	- 4.7			
NC 20 P 0 0154	150,000						
NC 20 P 0 0184	180,000						
NC 20 P 0 0224	220,000						
NC 20 Q 0 0274	270,000				Q	4300 ± 3%	- 4.7
NC 20 Q 0 0334	330,000						
NC 20 Q 0 0394	390,000						
NC 20 Q 0 0474	470,000						
NC 20 R 0 0564	560,000	R	4400 ± 3%	- 4.8			
NC 20 R 0 0684	680,000						
NC 20 R 0 0824	820,000						
NC 20 R 0 0105	1,000,000						



### AUTOMATIC INSERTION

#### Super 8 Plastic Tape Packaging:

The mechanical and dimensional reel characteristics are in accordance with the IEC publication 286-3.

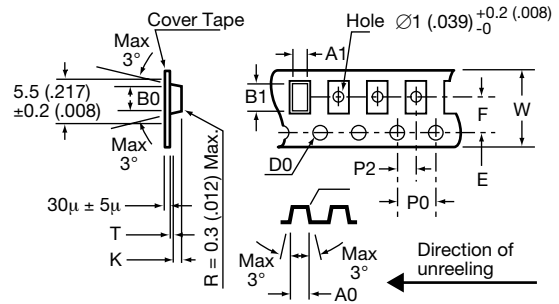

Designation	Symbol	Value	Tolerance	
Tape width	W	8	±0.2	
Tape thickness	T	0.4 max.		
Pitch of the sprocket holes	P0	4	±0.1	
Diameter of the sprocket holes	D0	1.5 -0	±0.1	
Distance	E	1.75	±0.1	
Distance (center to center)	F	3.5	±0.05	
Distance (center to center)	P2	2	±0.1	
Sizes of the cavities	NC 12 (0805)	A0	1.5	±0.1
		B0	2.4	±0.1
		K	1.4 max.	K ±0.1 (size is adjustable) (K = t1 +0.2)
NC 20 (1206)		A0	1.95	±0.1
		B0	3.55	±0.1
		K	1.5 max.	K ±0.1 (size is adjustable) (K = t1 +0.2)

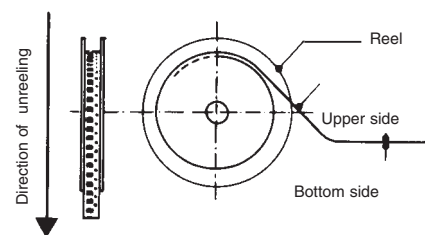

### QUANTITY PER REEL

Type	Suffix	Qty Per Reel
NC - NB 12	BA	4000
	BE	2000
NC 20 - NB 20	BA	3000
	BE	1500

# Packaging for Automatic Insertion



## NTC Chip Thermistors / NC/NB Series

### AUTOMATIC INSERTION

#### 8mm Paper Tape Packaging:

The mechanical and dimensional reel characteristics are in accordance with the IEC publication 286-3.



Designation	Symbol	Value	Tolerance
Tape width	W	8	$-.0.1/+0.3$
Tape thickness	T	1.1 max.	
Pitch of the sprocket holes	$P_0$	4	$\pm 0.1$
Diameter of the sprocket holes	$D_0$	1.5	$\pm 0.1$
Distance	$E_1$	1.75	$\pm 0.1$
Distance (center to center)	F	3.5	$\pm 0.05$
Distance (center to center)	$P_2$	2	$\pm 0.05$
Cover tape thickness	$T_1$	0.10 max.	
Distance	$E_2$	6.25 min.	
Distance	G	0.75 min.	
Component pitch	$P_1$	0805/0603	$\pm 0.1$
		0402	$\pm 0.1$

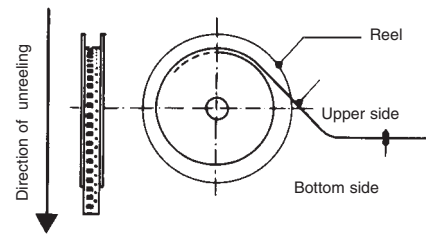

### QUANTITY PER REEL

Type	Suffix	Qty Per Reel
NB - NC 12	BB	4000
NB 21	BF	2000
NB 23	BB	10000
	BF	5000



# Surface Mounting Guide



## Chip Thermistor – Application Notes

### STORAGE

Good solderability is maintained for at least twelve months, provided the components are stored in their “as received” packaging at less than 40°C and 70% RH.

### SOLDERABILITY / LEACHING

Terminations to be well soldered after immersion in a 60/40 tin/lead solder bath at  $235 \pm 5^\circ\text{C}$  for  $2 \pm 1$  seconds.

Terminations will resist leaching for at least the immersion times and conditions recommendations shown below.

P/N	Termination Type	Solder Tin/Lead	Solder Temp °C	Immersion Time Seconds
NC	AgPdPt	60/40	$260 \pm 5$	15 max
NB	Nickel Barrier	60/40	$260 \pm 5$	$30 \pm 1$

NB products are compatible with a wide range of soldering conditions consistent with good manufacturing practice for surface mount components. This includes Pb free reflow processes with peak temperatures up to  $270^\circ\text{C}$ . Recommended profiles for reflow and wave soldering are shown below for reference.

NC products are recommended for lead soldering application or gluing techniques.

### Wave

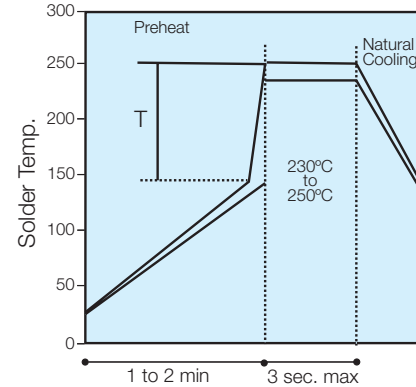

(Preheat chips before soldering)  
T/maximum  $150^\circ\text{C}$

- The visual standards used for evaluation of solder joints will need to be modified as lead free joints are not as bright as with tin-lead pastes and the fillet may not be as large.
- Resin color may darken slightly due to the increase in temperature required for the new pastes.
- Lead-free solder pastes do not allow the same self alignment as lead containing systems. Standard mounting pads are acceptable, but machine set up may need to be modified.

### Reflow



(Minimize soldering time)



- Pre-heating:  $150^\circ\text{C} \pm 15^\circ\text{C}$  / 60-90s
- Max. Peak Gradient:  $2.5^\circ\text{C/s}$
- Peak Temperature:  $245^\circ\text{C} \pm 5^\circ\text{C}$
- Time at  $>230^\circ\text{C}$ : 40s Max.

### RECOMMENDED SOLDERING PAD LAYOUT

Dimensions in mm (inches)



### REFLOW SOLDERING

Case Size	P/N	D1	D2	D3	D4	D5
0402	NB23	1.70 (.067)	0.60 (.024)	0.50 (.020)	0.60 (.024)	0.50 (.020)
0603	NB21	2.30 (.091)	0.80 (.031)	0.70 (.028)	0.80 (.031)	0.75 (.030)
0805	NB12	3.00 (.118)	1.00 (.039)	1.00 (.039)	1.00 (.039)	1.25 (.049)
1206	NB20	4.00 (.157)	1.00 (.039)	2.00 (.079)	1.00 (.039)	2.50 (.098)

### WAVE SOLDERING

Case Size	P/N	D1	D2	D3	D4	D5
0603	NB21	3.10 (.122)	1.20 (.047)	0.70 (.028)	1.20 (.047)	0.75 (.030)
0805	NB12	4.00 (.157)	1.50 (.059)	1.00 (.039)	1.50 (.059)	1.25 (.049)
1206	NB20	5.00 (.197)	1.50 (.059)	2.00 (.079)	1.50 (.059)	1.60 (.063)